



ZODIAC



MARSTM HP

**AUTOMATIC INGROUND
PRESSURE-SIDE
POOL CLEANER**

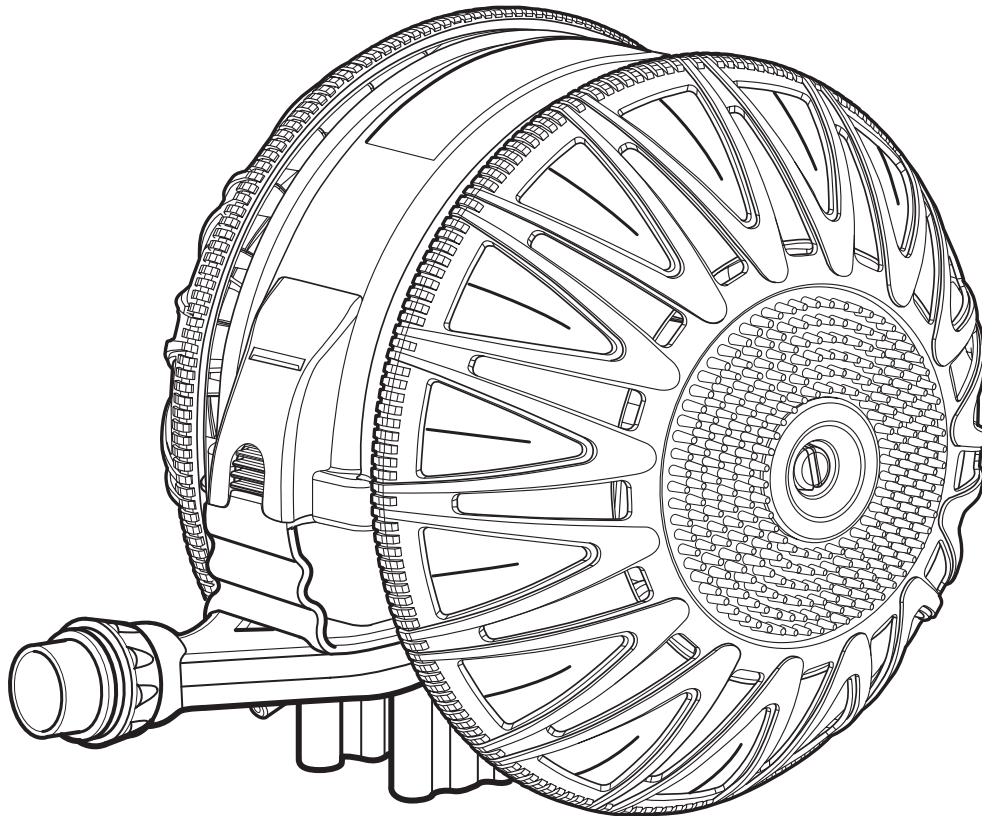

OWNER'S MANUAL

**Mars HP operates differently than other pressure-side pool cleaners.
Please read the entire manual to insure optimum performance.**

BARACUDA[®]
The World's Simplest Automatic Pool Cleaners



WARRANTY INFORMATION

Congratulations on purchasing the most innovative pressure-side pool cleaner available. Mars HP has been designed and manufactured to be easily installed and to provide years of low maintenance operation. Pool cleaning is reborn.

For future reference, record your Mars HP pool cleaner data here:

Mars HP Serial Number _____ (Located under the handle on the cleaner head)

Date of Purchase _____

Purchased from _____

City _____ State _____ Zip _____

For the following warranty to be in effect you must complete and return the attached warranty card within 15 days of purchase.

MARS HP LIMITED WARRANTY

This Mars HP was carefully inspected before shipment from our warehouse. Upon unpacking, if any part proves defective or missing, please notify Zodiac Pool Care, Inc. immediately. Please consult owner’s manual for complete instructions on the installation and operation of your Mars HP.

ZODIAC POOL CARE, INC. WARRANTS THE MARS HP POOL CLEANER AGAINST ALL MANUFACTURING DEFECTS, ALL WEAR AND TEAR FOR THE FIRST TWO (2) YEARS. THE MARS HP HOSE IS WARRANTED AGAINST DEFECTS AND WEAR AND TEAR FOR TWO (2) YEARS. ALL WARRANTIES ARE EFFECTIVE FROM THE DATE OF PURCHASE.

Should this product prove defective in workmanship, materials or wear during the applicable warranty period, the consumer’s sole and exclusive remedy shall be such repair or replacement of the product as provided below.

THIS LIMITED WARRANTY EXCLUDES THE FOLLOWING:

1. Discoloration of the Mars HP pool cleaner. This is caused by reaction to ultraviolet rays and the chemicals used in the pool water. Discoloration does not affect the operating ability of the Mars HP. Therefore, this Limited Warranty does not cover the replacement of discolored parts.
2. Damage to or malfunction of the unit resulting from excess chlorination or improper water chemistry balance.
3. Replacement of parts which fail or become defective as a result of improper installation, negligence, misuse, abuse or tampering by unauthorized repair personnel.
4. Age, pool water imbalance, and improper installation can cause vinyl pool liners to become brittle or unduly wrinkled. Corrosion of the supporting walls and/or irregularities in the pool base may also cause liner failure. The use of this product in such an environment is at the pool owner’s risk. Therefore, the pool owner hereby releases the manufacturer from any and all claims for damage where these conditions exist.
5. The Mars HP is designed for use in inground pools only. If unit is used in any other application, the pool owner hereby releases the manufacturer from any and all claims. This misuse will void all warranty on the unit.

THE LIMITED WARRANTY PROVIDED HEREIN IS THE SOLE AND EXCLUSIVE WRITTEN WARRANTY WITH RESPECT TO THE MARS HP POOL CLEANER. ALL IMPLIED WARRANTIES IMPOSED BY APPLICABLE LAW, INCLUDING ANY IMPLIED WARRANTY OF MERCHANTABILITY OR FITNESS FOR A PARTICULAR PURPOSE, WITH RESPECT TO EACH COMPONENT OF THE MARS HP ARE LIMITED TO THE DURATION OF THE EXPRESS LIMITED WARRANTY WITH RESPECT TO SUCH COMPONENT. SOME STATES DO NOT ALLOW LIMITATIONS ON HOW LONG AN IMPLIED WARRANTY LASTS, SO THE ABOVE LIMITATION MAY NOT APPLY TO YOU.

In no event shall Zodiac Pool Care, Inc. be liable in contract or in tort, or under any other legal theory, for lost profits or revenues, loss of use or similar economic loss, or for indirect, special, incidental, consequential or similar damages, even if it has been advised of the possibility of such claim. Some states do not allow the exclusion or limitation of incidental or consequential damages, so the above limitation or exclusion may not apply to you.

No claim under this Limited Warranty will be recognized unless the warranty card, included in your box, is completed and returned within fifteen (15) days of the purchase date. **Only the original purchaser may submit a claim under this Limited Warranty.** Purchaser’s claims against Zodiac Pool Care, Inc. shall be limited to those claims which may be asserted under the Limited Warranty relating to any defect, malfunction or wear of the Mars HP.

To obtain warranty replacements or repair, call (888) 786-7797 for warranty station referral. When calling, always supply serial number, evidence of purchase date, retailer and a brief description of the problems/defects encountered. Zodiac Pool Care, Inc. reserves the right to repair or replace all defective or worn parts covered by this Limited Warranty and return same to purchaser, freight collect.

Zodiac Pool Care, Inc. assumes no responsibility for any warranties or representations made by other individuals or businesses beyond the express terms contained in this Limited Warranty.

This warranty gives you specific legal rights, and you may also have other rights which vary from state to state.

For sale and use in the United States, Canada and Mexico only. This pool cleaner is not warranted or guaranteed outside of the United States, Canada or Mexico.

This pool cleaner is covered by U.S. Patent Number D430906.

TABLE OF CONTENTS

Product Introduction and Pool Preparation	3
Supply Hose Adjustment and Installation	4
Operation	9
Debris Trap	11
Care and Maintenance	13
Troubleshooting	17
Parts Diagram	18

PARTS IDENTIFICATION

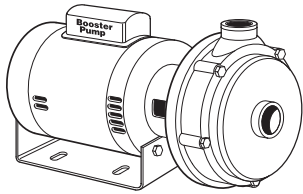

Booster Pump
(Purchased separately)

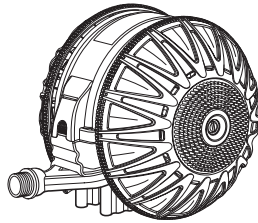

Mars HP Head

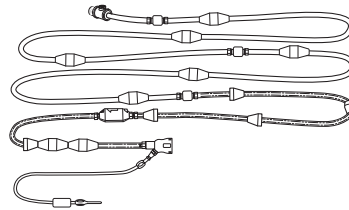

Supply Hose

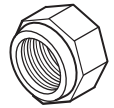

Mender Nut

If any of the above parts are missing or damaged, contact our Customer Service hotline at 1-800-871-0712 for immediate assistance.

PRODUCT INTRODUCTION

Welcome to Mars™ HP, the simplest, most innovative pressure-side pool cleaner. Its simple design will provide superior pool cleaning and years of carefree maintenance.

Mars HP operates differently than other pressure-side pool cleaners. Please read the entire manual to insure optimum performance.

Mars HP is powered by a booster pump. Installation and operating instructions for the booster pump are included with the pump. The booster pump must be installed according to local electrical codes in your area. Improper installation can result in fatal or serious injury.

If you had a different brand pressure-side cleaner, you may have purchased Mars HP as a head and hose assembly only. You may use your existing booster pump, but to insure optimum performance, **do not use** your existing hose. Follow the instructions using the Mars HP supply hose that came with your Mars HP pool cleaner.

POOL PREPARATION

Your swimming pool will require basic preparation before installing your Mars HP pool cleaner. Please do the following:

- Properly install the booster pump.
- Empty the skimmer basket and hair & lint basket.
- Clean the pool filter according to the manufacturer's instructions.
- Manually remove large debris or children's toys.
- Turn off your pool filtration pump and booster pump.

SUPPLY HOSE INSTALLATION AND ADJUSTMENT

The Mars HP supply hose consists of 20 feet of white hose and 10 feet of clear hose with floats which are attached together with swivels and secured by mender nuts. **Important:** Before adjusting the length of the supply hose, remove the complete supply hose from the box and lay it in a straight line in the sun to relax any coiling that may have occurred during shipping.

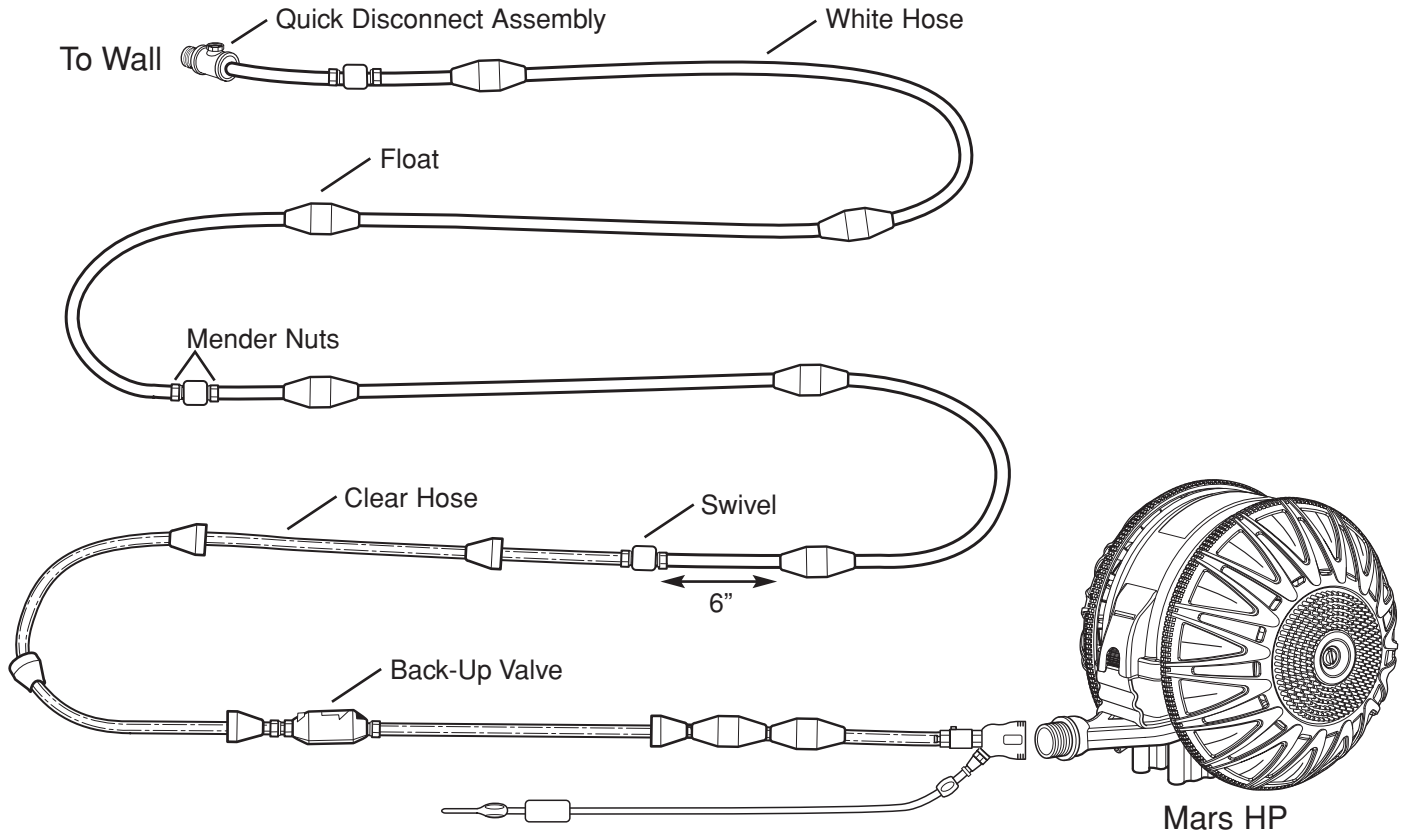

STEP 1: QUICK DISCONNECT ASSEMBLY INSTALLATION

The white section of the Mars HP supply hose has a quick disconnect with a universal wall fitting, an in-line screen and a pressure relief valve. **NOTE:** The in-line screen filters out fine debris and will need to be cleaned periodically. The pressure relief valve is used to adjust the wheel RPM as explained later in the manual.

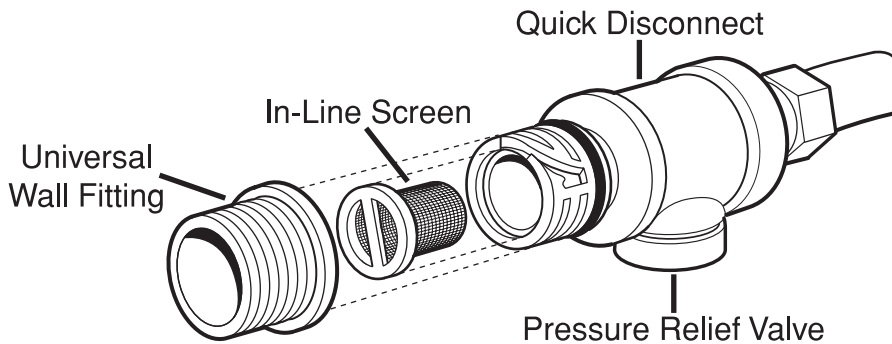

- Thread the universal wall fitting into the dedicated cleaner line.
- Lock the quick disconnect into the universal wall fitting.

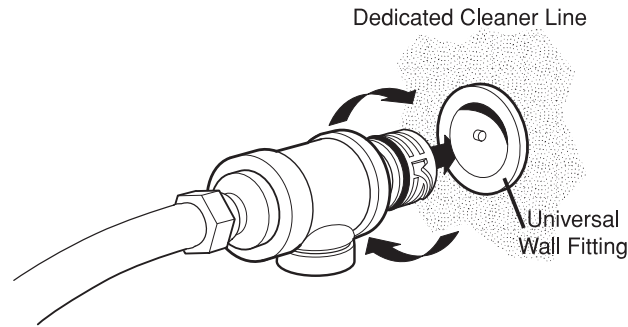

STEP 2: TOTAL SUPPLY HOSE MEASUREMENT

The proper length of the Mars HP supply hose is critical for optimum performance. Read this section carefully before making adjustments.

- First, measure the distance from the dedicated cleaner line to the farthest point in the pool.
- Add 3 additional feet. This distance will be the **total supply hose** length, (clear hose & white hose) required for your pool.

NOTE: If this distance is between 27' and 30' use the complete supply hose, no adjustment is required, move to step 4.

If this distance is longer than 30' contact your local Zodiac dealer for additional supply hose. You will need part number W36450.

If this distance is shorter than 27', you will need to adjust the supply hose length.

STEP 3: ADJUSTING THE SUPPLY HOSE LENGTH

- Measure the clear hose, so that its length is 2' longer than the depth of your pool. If your pool is 8' deep or greater, do not shorten the clear hose. (Read on as the white hose may need to be adjusted.)
- Remove the clear hose from the swivel that connects it to the white hose.

NOTE: To remove ANY hose section from a swivel, loosen the mender nut and pull the hose off of the swivel.

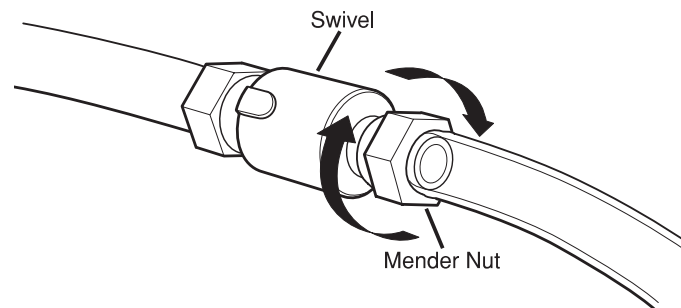

- Cut the pre-measured clear hose from the end you removed from the swivel.
- Re-attach the clear hose to the swivel.

NOTE: To attach ANY hose section to a swivel, slide the mender nut onto the swivel, with the smooth collar facing the swivel, then push the hose onto the barbed end of the swivel and tighten the mender nut. This procedure will be easier if the hose is wet.

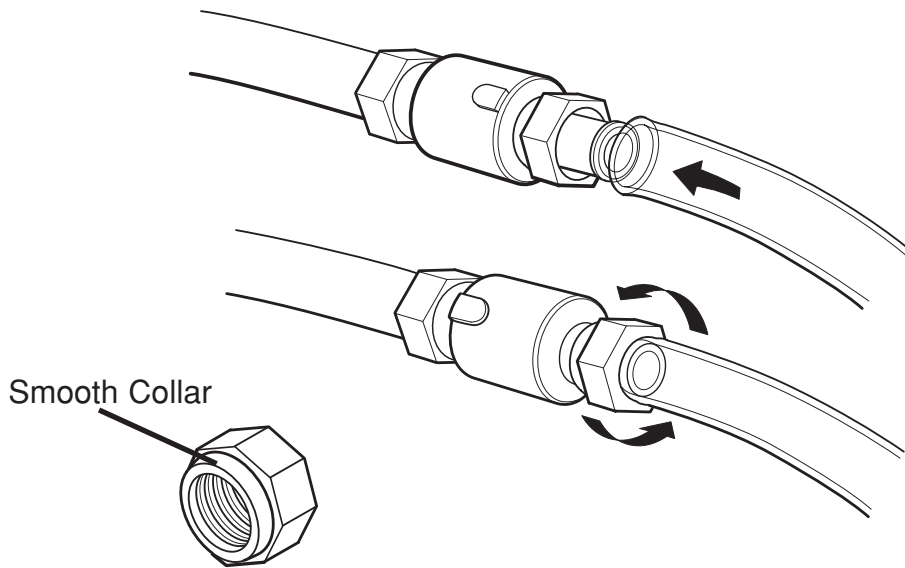

- Subtract the length of the clear hose from the total supply hose length. This measurement will be the required length of the white hose.

Example:

- 1 The pool is a 15'x30' rectangle, 6' deep.
 - 2 The measured distance from the dedicated cleaner line to the farthest point of the pool is 21'.
 - 3 After adding 3 additional feet, the total supply hose length is 24'. The clear hose is cut so that it measures 8' (2' longer than the depth of the pool).
 - 4 After subtracting the 8' of clear hose from the total supply hose length of 24', the white hose will be measured and cut to 16 feet (24' of total supply hose less the 8' of clear hose). (This is an example only - your pool may vary.)
- Remove the white hose from the swivel that connects it to the clear hose.

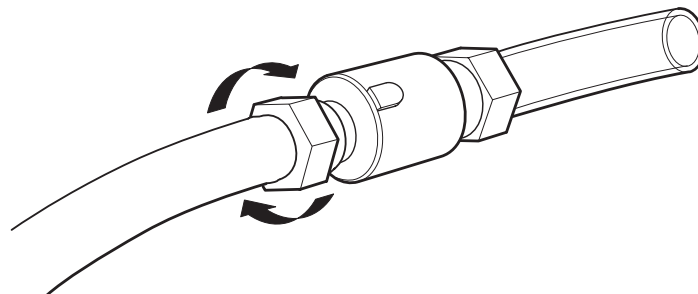

- Measure and cut the end of the white hose you removed from the swivel, as instructed for your size pool. You may be removing hose floats.

POSITIONING HOSE FLOATS

IMPORTANT: For the Mars HP to work properly, it is important that the hose floats are in the correct positions.

- The factory setting for the 1 small and 2 large floats nearest the cleaner is for them to be all pushed together and 9 inches from the swivel attached to the cleaner head.
- To increase the cleaning ability of the unit, these 3 floats can be pushed 3 to 6 inches further away from the cleaner, keeping the 3 floats together. If the Mars HP unit is tipping onto one wheel or on it's side, these 3 floats have been moved back too far (or removed).
- There must always be a hose float on the white hose, within 6" from the swivel, which connects the white hose to the clear hose. You may need to replace one of the hose floats that were removed during adjustment to insure that a float is within 6" from this swivel.

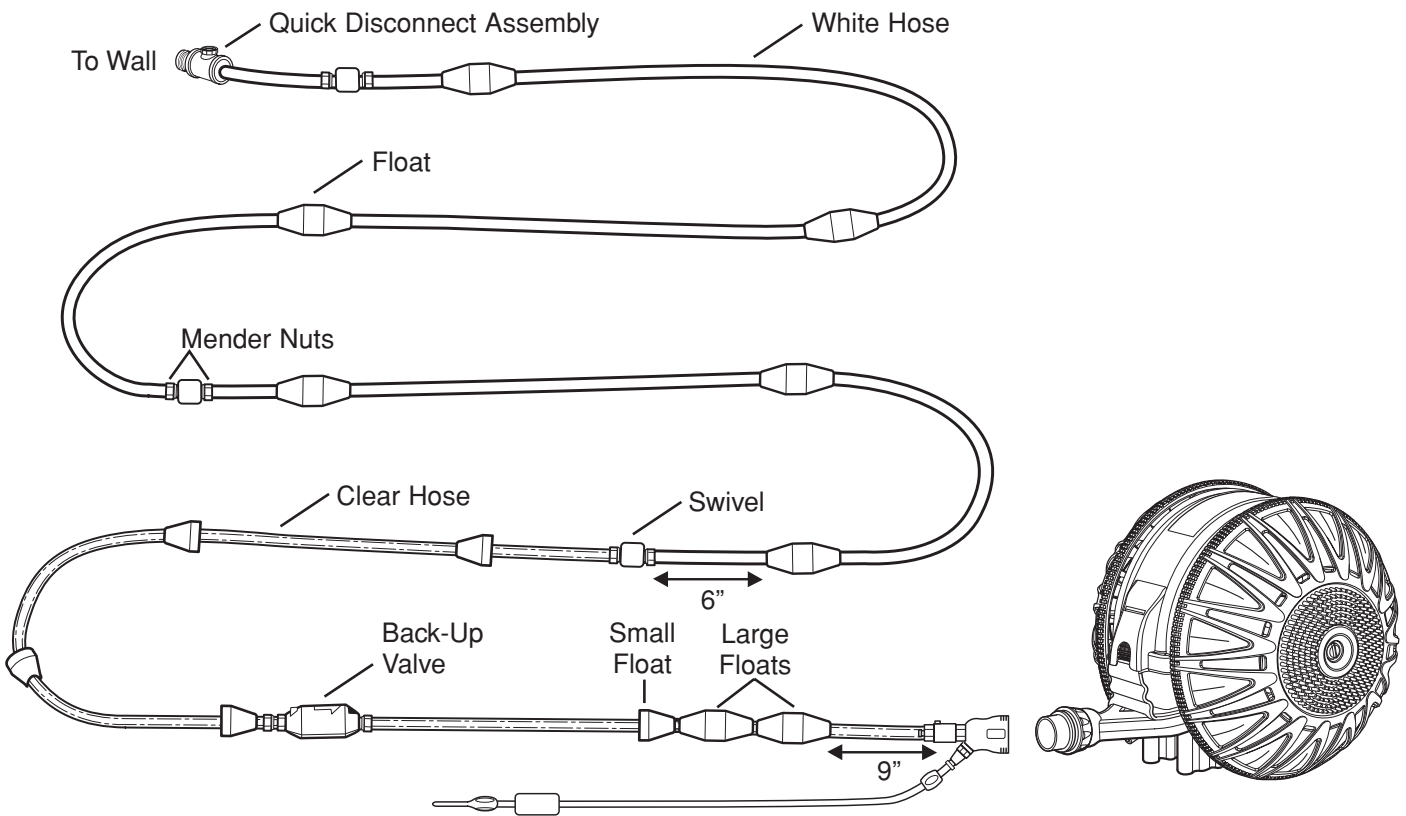

- Once the hose floats are in the correct position, re-attach the white hose to the swivel, securing it with a mender nut.

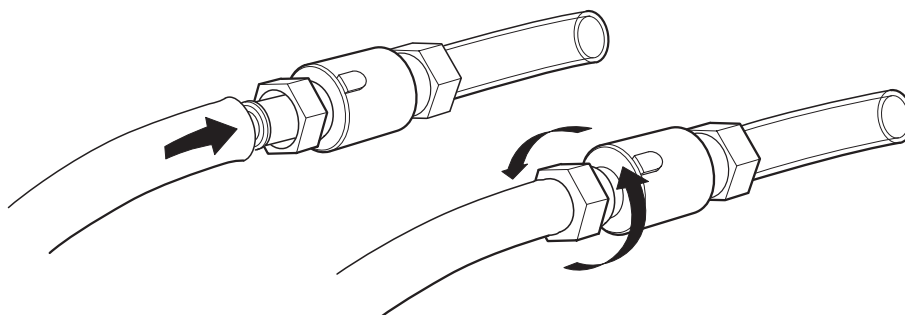

STEP 4: INSTALLING THE MARS CLEANER

- Attach the Mars HP head to the clear hose end. Take the female end of the handle, which is attached to the clear hose, and slide it over the male end of the handle, which is attached to the cleaner head. Handle will snap into place.

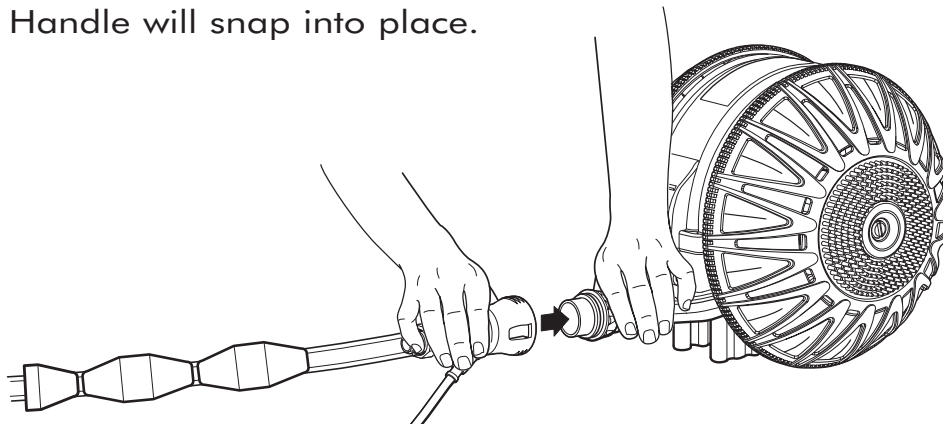

- To remove the cleaner head from the hose, squeeze the female handle at the grips and pull.

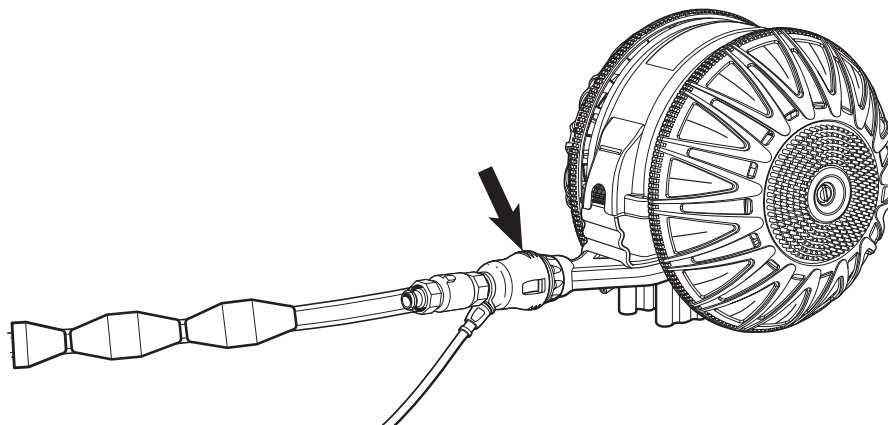

- Confirm that the yellow RPM count decal is in the center of one of the Mars HP wheels. If not, apply one of the yellow RPM count decals at this time. Submerge the Mars HP cleaner in the swimming pool until the air bubbles stop. (The quick disconnect should still be connected to the wall.) Allow the Mars HP cleaner to sink.

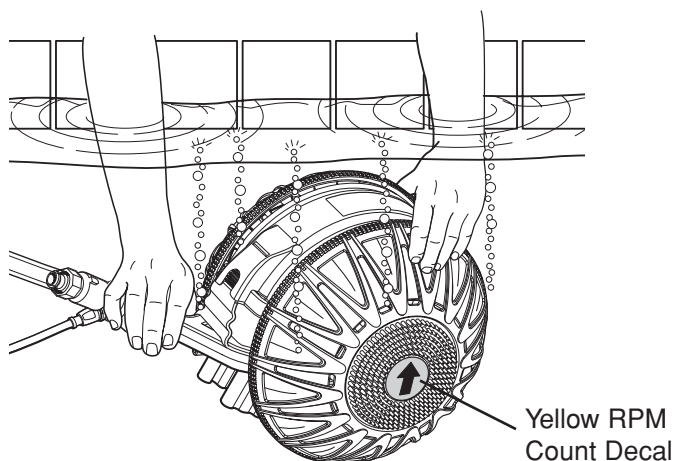

OPERATION

Turn on the pool filtration pump and wait 30 seconds before turning on the booster pump. If your Mars HP pool cleaner is set to run on a timer, be sure that the booster pump turns on after and shuts off before, the filtration pump.

Your Mars HP pool cleaner will randomly clean an average swimming pool in 3 hours or less. A back-up jet, which cycles on and off for approximately 45 seconds every 3 minutes, will pull the Mars HP cleaner into a different position to improve coverage.

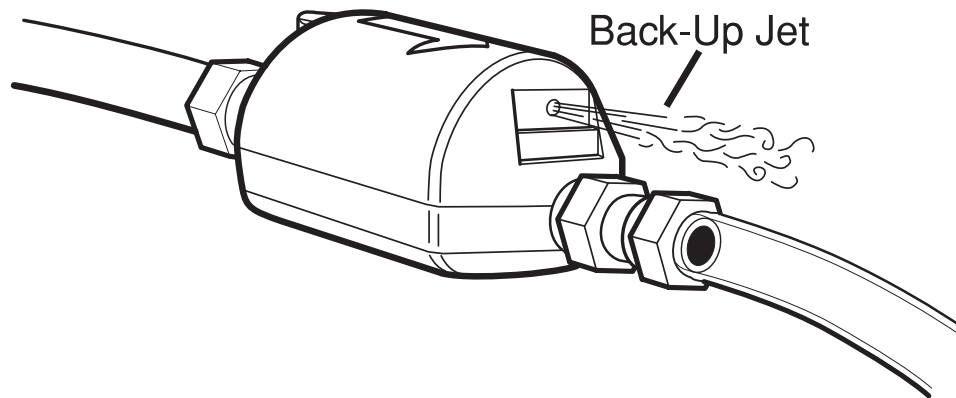

WHEEL RPM ADJUSTMENT

- To determine if your Mars HP pool cleaner is operating at the correct speed, you must count the wheel RPM.
- To count wheel RPM (Revolutions Per Minute), hold the Mars HP head sideways, just below the surface to avoid being sprayed by water.
- The pressure relief valve on the Mars HP quick disconnect assembly is shipped in the OPEN position, which will most likely result in wheel RPM below 40.
- Failure to adjust the pressure relief valve to achieve proper wheel RPM can result in improper cleaner performance.
- **After the back-up jet has completed one cycle,** use the arrow on the yellow RPM count decal for easier RPM counting and begin timing the wheel revolutions for 1 minute.
- The ideal wheel RPM is between 40 and 48. If your wheel RPM is between 40 and 48, remove the yellow decal and allow the Mars HP cleaner to clean your pool. Your installation is now complete.
- We have included additional RPM count decals for future use. Keep them along with your Mars HP owner's manual.

If your wheel RPM is below 40, please do the following:

- Turn off booster pump.
- Adjust the pressure relief valve on the quick disconnect by gradually turning it clockwise to increase wheel RPM (pliers may be needed).
- Clean the in-line screen at the universal wall fitting/quick disconnect.
- Check the entire supply hose for leaks at the swivels.
- If applicable, confirm that the gate valve on the dedicated cleaner line is fully open. Contact your dealer if needed.
- Clean the pool filter, skimmer basket and pump basket.
- Turn on booster pump.
- Retest the wheel RPM.
- Once your wheel RPM is between 40 and 48, remove the yellow RPM count decal and allow the Mars HP to clean your pool. Your installation is now complete.

If your wheel RPM is above 48:

- Turn off the booster pump.
- Adjust the pressure relief valve on the quick disconnect by gradually turning it counter clockwise to decrease wheel RPM (pliers may be needed).
- Turn on booster pump and retest the wheel RPM.
- Once your wheel RPM is between 40 and 48, remove the yellow RPM count decal and allow the Mars HP to clean your pool. Your installation is now complete.



In the event that your wheel RPM continues to read below 40 or above 48, call our technical service hotline at 1-888-786-7797 for further assistance.

DEBRIS TRAP

To empty the debris trap

- Turn off the booster pump and remove the Mars HP head from the swimming pool.
- Press the purple button located just above the handle while lifting the debris trap away from the Mars HP head.

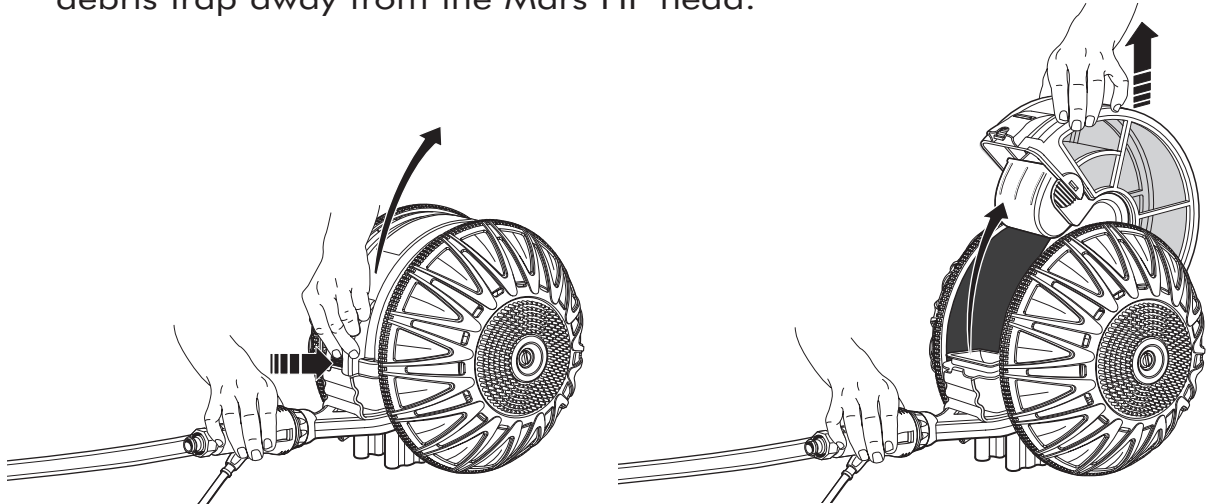

- Pinch the 2 clips on either side of the debris trap to open it.

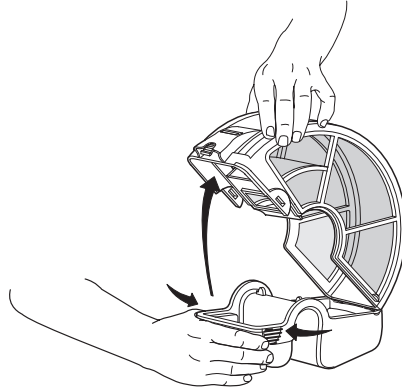

- Empty and gently rinse both halves of the debris trap.

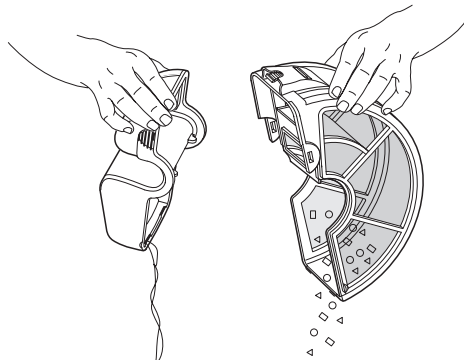

IMPORTANT: Sharp objects or high-pressure water can puncture or tear the mesh panels. Use caution when emptying and rinsing.

- Seat the hinge tabs on the top of the debris trap before snapping the clips shut.

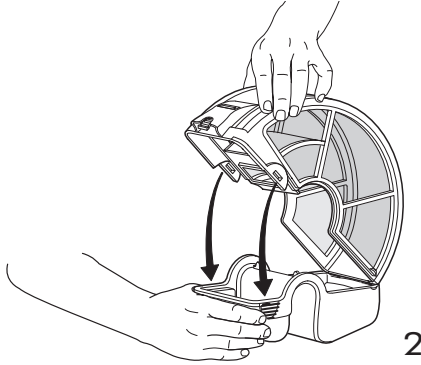
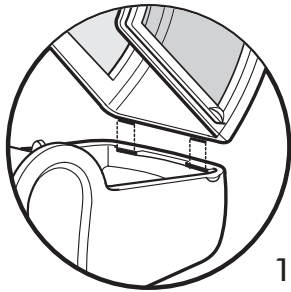

- Seat the base of the debris trap before allowing the purple button to lock into place.

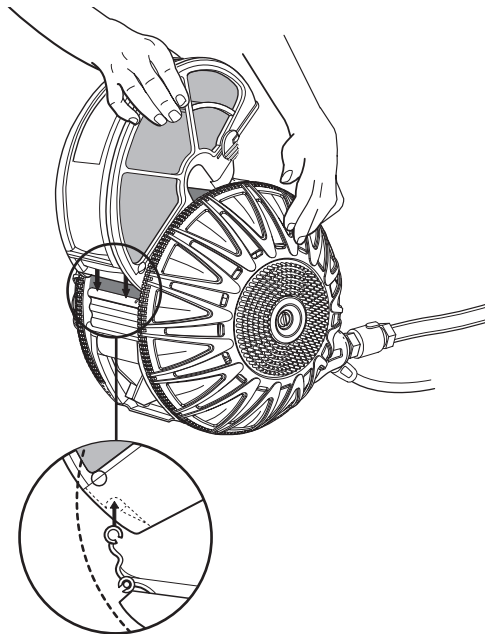

- Be sure that the debris trap is secure.

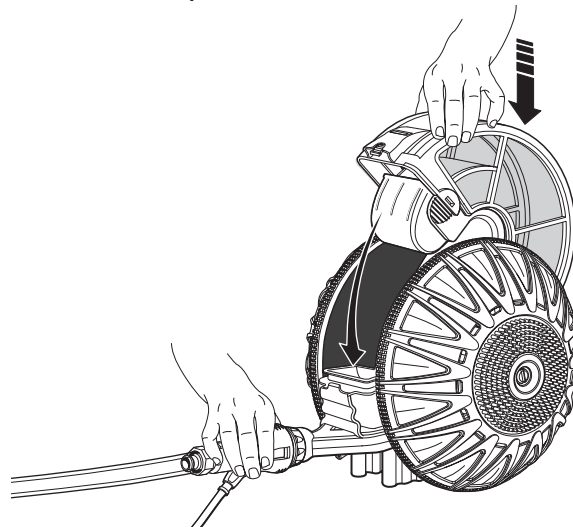

CARE AND MAINTENANCE

Your Mars HP pool cleaner has been designed and manufactured to provide years of carefree maintenance. Please follow the guidelines below to help insure optimum performance.

- Your Mars HP pool cleaner is not a toy. Do not allow children to play with the Mars HP pool cleaner. **Remove the Mars HP pool cleaner from the pool before swimming.**
- When Mars HP is out of the pool, **do not coil the supply hose.** Coiling will result in poor coverage due to supply hose memory.
- Do not lay objects on top of the Mars HP unit. During off season storage, insure unit is stored in flat area without applying pressure to the wheels.
- Store the Mars HP head on its side when not in use, to avoid possible distortion of the wheels.
- Never run the booster pump if the filtration pump is not running. This may cause booster pump damage that will not be covered under warranty.
- Regularly clean the in-line screen at the universal wall fitting/quick disconnect. This screen prevents fine debris from clogging water jets in the Mars HP head. **Never run your Mars HP pool cleaner without the in-line screen in place.**
- In freezing conditions, drain your Mars HP pool cleaner and supply hose and remove them from the pool. Remove the drain plug from the booster pump and drain all of the water out of the pump.
- Always remove the Mars HP pool cleaner when chemically balancing or super-chlorinating the pool. Replace the Mars HP pool cleaner after the water is properly balanced or after 4 hours from super-chlorinating the pool.
- Periodically inspect the tires and wear strip for wear and replace as needed. Follow the instructions to disassemble and replace these parts. See the parts diagram for identification. Contact our technical service department for any parts that may be needed at 1-888-786-7797.

SWEEP REMOVAL (Optional)

Your Mars HP cleaner comes preassembled with a power sweep attached to the female end of the inlet handle, at the end of the clear hose section. To remove the sweep, please follow the steps below:

- Turn off the booster pump and remove the Mars HP head from the pool.
- Unscrew the mender nut that connects the sweep to the female end of the inlet handle.
- Remove the sweep. As the sweep is disconnected from the inlet handle, a valve will close sealing the inlet handle.

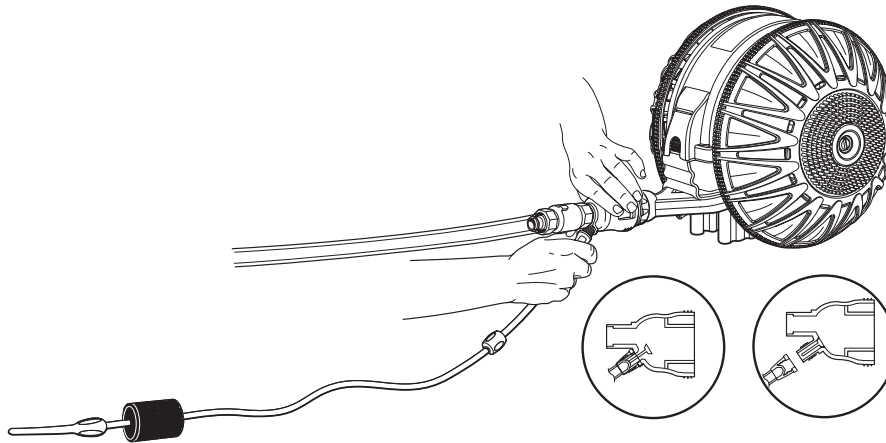

SCRUBBER INSPECTION AND REPLACEMENT

- Turn off the booster pump and remove the Mars HP head from the pool.
- Remove the sweep from the hose assembly using the method described above.
- Inspect the scrubber by turning it over looking for wear points.
- Slowly pull the scrubber toward the end of the sweep, away from the connection point, and remove.

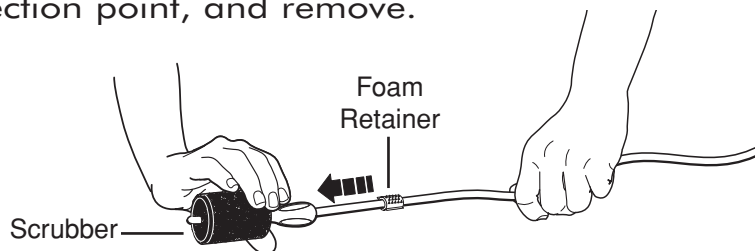

- Install replacement scrubber by pushing it into place over the end of the sweep. The scrubber should be positioned so that the foam retainer is located near the center on the scrubber. This will hold the scrubber in place. Use the replacement scrubber included with your Mars HP, or call your local Zodiac dealer. You will need part number W40015.
- When installing a replacement scrubber, inspect the foam retainer to insure the spikes are intact. If the spikes are worn, you will need to replace it with part number W83198.

WEAR STRIP INSPECTION AND REPLACEMENT

- Turn off the booster pump and remove the Mars HP head from the pool.
- For easier inspection, remove the debris trap.
- Turn the Mars HP head upside down and inspect the wear strip on the debris door. The wear strip should be replaced when any part of the leading edge of the wear strip has worn down to the hard plastic of the debris door.

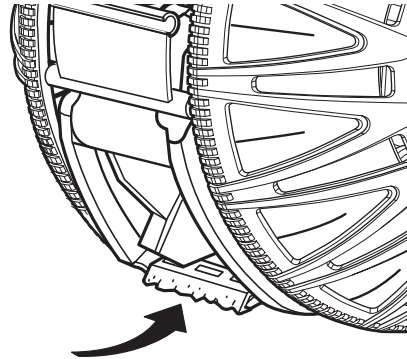

- To remove the wear strip, press the bottom trailing edge of the wear strip gently upwards. This will distort the wear strip sufficiently to allow it to be pulled off the locating tabs on the top face of the wear strip. Then, the wear strip can simply be pulled off the debris door.

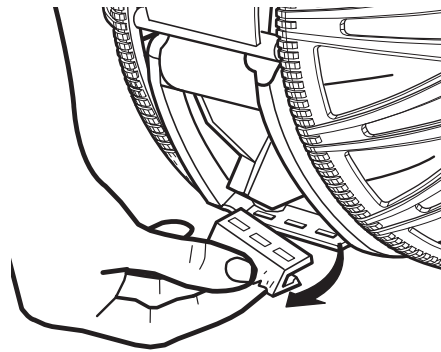

- To fit a new wear strip, simply position the wear strip in line with the locating clips and push into place. Insure the clips are correctly located in the wear strip cut outs provided.

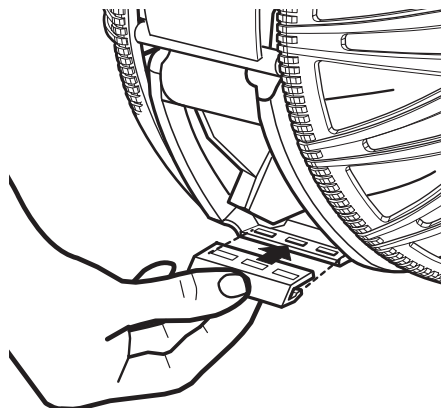

TIRE INSPECTION AND REPLACEMENT

- For easier inspection remove the debris trap.
- Inspect the tread on the edge of the tires for wear. When the tread of the tire has worn smooth, replace the tire.

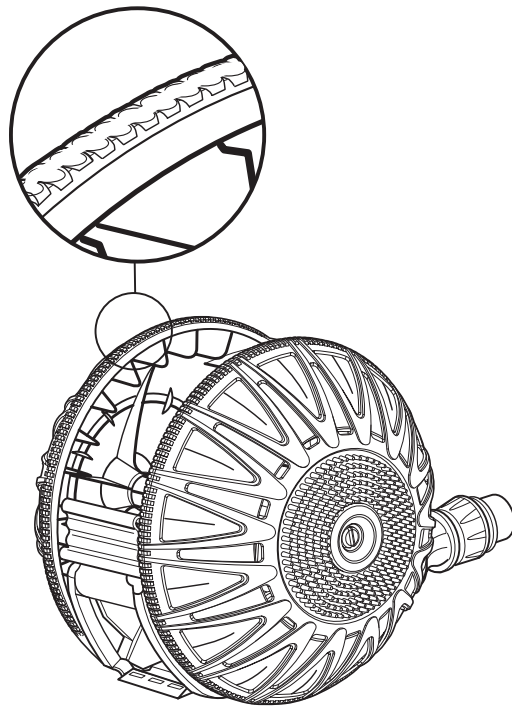

- To replace the tire, simply peel the old tire off of the wheel.
- Center the new tire onto the wheel and gently stretch the tire onto the wheel. Insure that the edge of the new tire is properly seated along the inner groove of the wheel.

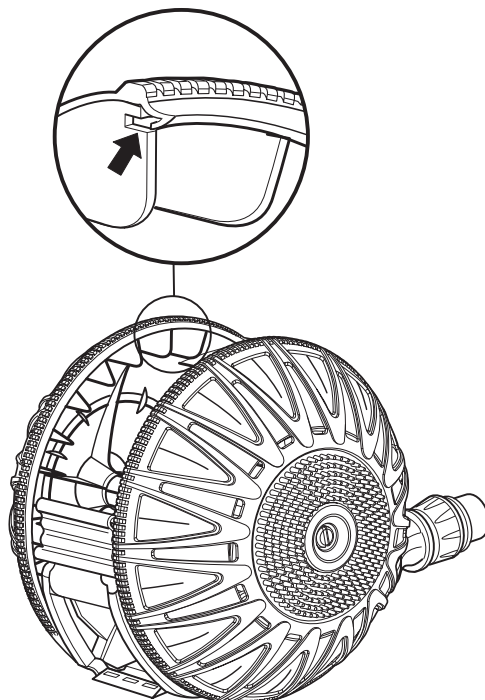

TROUBLESHOOTING

Most problems with your Mars HP pool cleaner are easily remedied by simple adjustments. Follow the suggested solutions in the order shown below. If the problem continues after trying the suggestions below, please call our technical service hotline at 1-888-786-7797.

PROBLEM	SOLUTION
Mars HP sticks in corners or in-pool obstacles for longer than 4 minutes.	<ul style="list-style-type: none">• Confirm wheel RPM is between 40 and 48.• Check to see that the backup valve is working properly. If not call 1-888-786-7797.• Check that the wheels spin freely. Turn off the booster pump and spin the wheels.
Mars HP is missing large areas of the pool.	<ul style="list-style-type: none">• Confirm wheel RPM is between 40 and 48.• Clean the in-line screen at the universal wall fitting/quick disconnect.• Check the supply hose for coiling.• Confirm that the supply hose length is correct for your pool.• Move the hose float on the white hose that is located nearest the clear hose, back 2' from the swivel.• Empty the debris trap.• Confirm that the back-up jet is operating.• Check that the wheels spin freely.
Mars HP will not climb the pool walls.	<ul style="list-style-type: none">• Confirm the wheel RPM is between 40 and 48.• Empty the debris trap. Rinse the mesh panels.• Clean the in-line screen at the universal wall fitting/quick disconnect.• Check the tires for excessive wear, replace as needed.• Check the supply hose for coiling.
Mars HP supply hose coils in pool.	<ul style="list-style-type: none">• Remove the supply hose from the pool and lay in the sun in a straight line for a few hours.• Confirm that the wheel RPM is between 40 and 48 and check the in-line screen.• Empty the debris trap.• Confirm that the supply hose length is correct for your pool.
Mars HP periodically floats to the surface.	<ul style="list-style-type: none">• Repair pool filtration/booster system problem that causes air to enter the pressure lines.
Mars HP is tipping onto one wheel or on it's side.	<ul style="list-style-type: none">• Confirm that the hose floats are in the correct position.

**For further assistance, please call our
Mars HP Technical Service Hotline
1-888-786-7797**

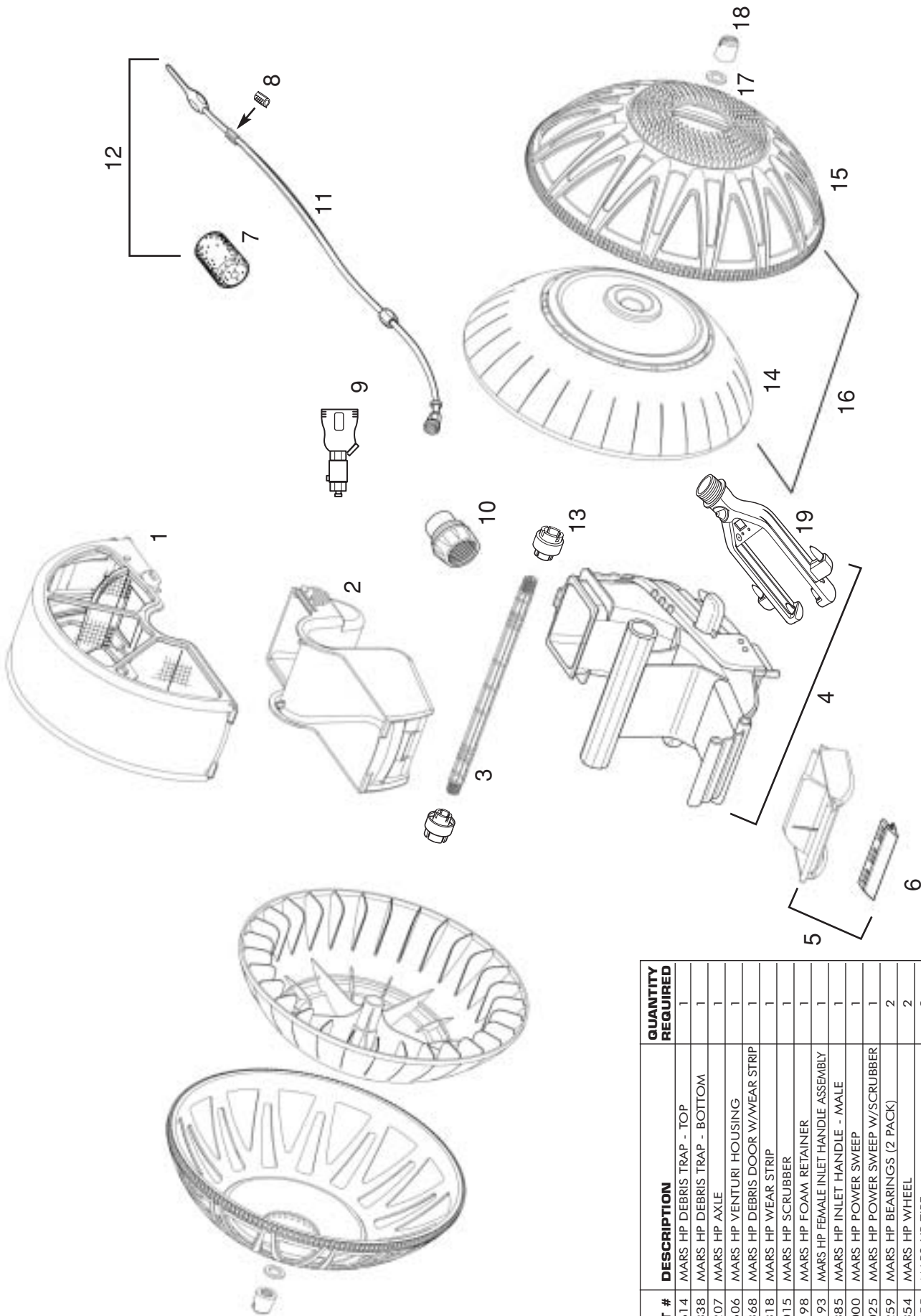

PART #	DESCRIPTION	QUANTITY REQUIRED
1	MARS HP DEBRIS TRAP - TOP	1
2	MARS HP DEBRIS TRAP - BOTTOM	1
3	MARS HP AXLE	1
4	MARS HP VENTURI HOUSING	1
5	MARS HP DEBRIS DOOR W/WEAR STRIP	1
6	MARS HP WEAR STRIP	1
7	MARS HP SCRUBBER	1
8	MARS HP FOAM RETAINER	1
9	MARS HP FEMALE INLET HANDLE ASSEMBLY	1
10	MARS HP INLET HANDLE - MALE	1
11	MARS HP POWER SWEEP	1
12	MARS HP POWER SWEEP W/SCRUBBER	1
13	MARS HP BEARINGS (2 PACK)	2
14	MARS HP WHEEL	2
15	MARS HP TIRE	2
16	MARS HP WHEEL ASSEMBLY	2
17	MARS HP WASHER	2
18	MARS HP NUT	2
19	MARS HP FMS KIT	1

Mars Supply Hose (31)

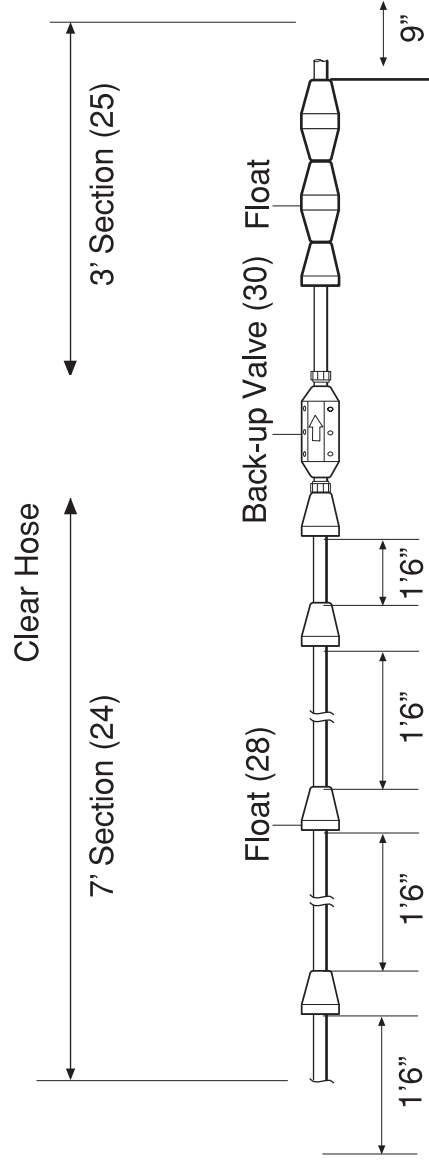
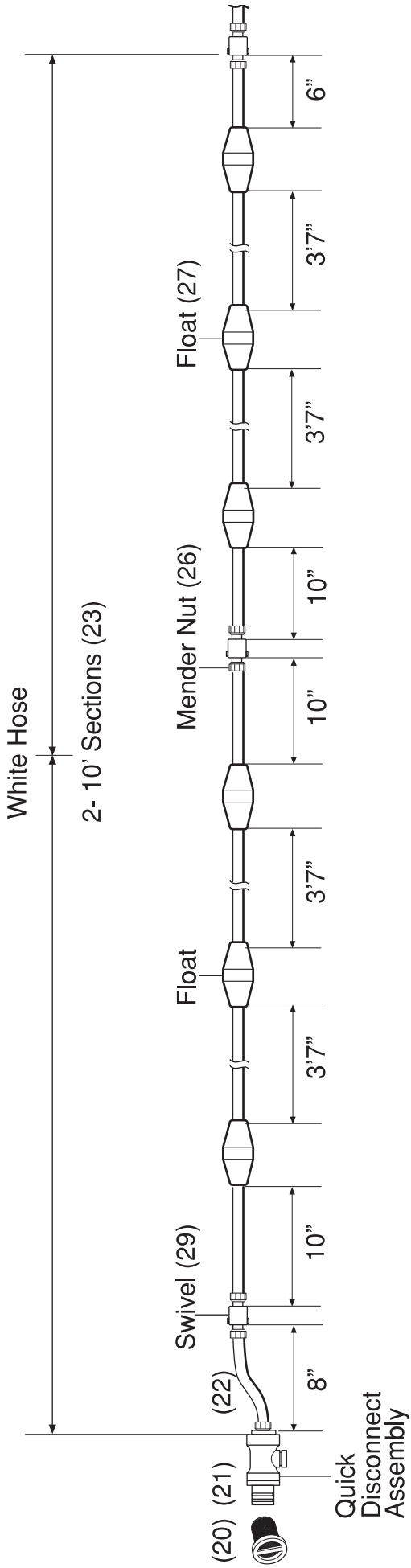

PART #	DESCRIPTION	QUANTITY REQUIRED
20	W36321 MARS HP WALL FITTING SCREEN	1
21	W36316 MARS HP QUICK DISCONNECT ASSEMBLY	1
22	W36318 MARS HP HOSE SECTION 8" WHITE	1
23	W36405 MARS HP HOSE SECTION 10' WHITE	2
24	W36370 MARS HP HOSE SECTION 7' CLEAR	1
25	W36330 MARS HP HOSE SECTION 3' CLEAR	1
26	W36310 MARS HP MENDER NUT	10
27	W36311 MARS HP HOSE FLOATS - LARGE	8
28	W36320 MARS HP HOSE FLOATS - SMALL	5
29	W36313 MARS HP HOSE SWIVEL	3
30	W36317 MARS HP BACK-UP VALVE	1
31	W36300 MARS HP SUPPLY HOSE COMPLETE	1

