

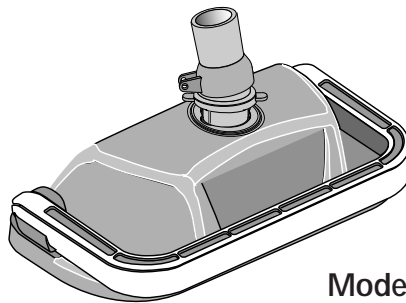

AUTOMATIC POOL CLEANER

O W N E R ' S M A N U A L



Model GW9500

OPERATION, TROUBLESHOOTING & PARTS

ABOUT SAFETY

- Before installing the cleaner, review and understand all warnings and safety information on inside cover of manual.

ABOUT INSTALLATION

- Please use the convenient, water resistant "EASY STEPS" card.

INDEX

About Safety	2	About Troubleshooting	6
About Your Pool and Filter System	2	About Maintenance	7
About Installation	3	About Disassembly	8
About the Cleaner Operation.....	4	About Assembly.....	9
About "Fine Tuning" Vacuum Adjustments.....	4,5	Repair Parts.....	10
About the Cleaner and Accessories.....	5	Warranty.....	11

Sta-Rite Pool/Spa Group

293 Wright Street, Delavan, WI 53115

North America: 800-752-0183, FAX 800-582-2217

International: 414-728-5551, FAX: 414-728-4461, TELEX: ITT 4970245

Union City, TN • Delavan, WI • Mississauga, Ont. • Murrieta, CA

Please read the following before installing your new automatic pool cleaner!

ABOUT SAFETY:

⚠ This is the safety alert symbol. When you see this symbol on your system or in this manual, look for one of the following signal words and be alert to the potential for personal injury.

⚠ DANGER warns about hazards that **will** cause death, serious personal injury, or major property damage if ignored.

⚠ WARNING warns about hazards that **can** cause death, serious personal injury, or major property damage if ignored.

⚠ CAUTION warns about hazards that **will** or **can** cause minor personal injury or property damage if ignored.

Carefully read and follow all safety instructions in this manual and on equipment. Keep safety labels in good condition; replace if missing or damaged.

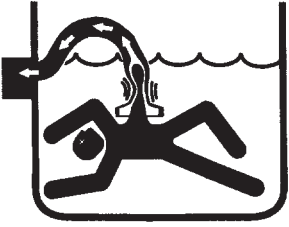
⚠ WARNING	Hazardous suction. Can trap and tear hair or body parts. Can cause drowning. Do not play with cleaner or hose or apply to body. Do not let children use or play with pool cleaner. Stop pump before attempting to clean unit.
	

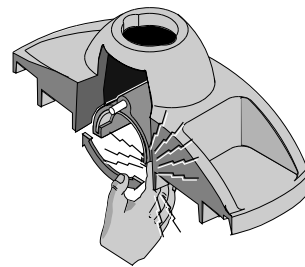

⚠ CAUTION **Oscillator may injure hands or fingers. Stop pump** before attempting to clean out pool cleaner head.

⚠ WARNING **Hose can trip or entangle swimmers. Do not allow swimmers in pool while pool cleaner is operating.**

ABOUT YOUR POOL AND FILTER SYSTEM:

⚠ Before installing your cleaner, review and understand all warnings and safety information on the inside front cover of this manual.

Pre-installation check list

Before installing the cleaner in a vinyl liner pool:

Check liner closely for signs of deterioration or damage from age, chemicals, pool wall damage, etc. If any damage is found, have a qualified pool professional make all necessary repairs. Also, if there are stones, roots, etc., under the liner, remove them before installing the cleaner.

Before installing the cleaner in a gunite pool or a pool that is partially or completely tiled:

Repair loose tiles and tighten any loose light rings.

Before installing the cleaner, clean your filter system:

Make sure you have cleaned the filter, including backwashing, rinsing, and emptying all baskets. A clean system is necessary for proper cleaner operation and coverage.

Before installing the cleaner, fill the hose with water:

Always make sure the cleaner head is submerged and the hose is full of water before connecting the hose to the filtration system (whether through a skimmer or dedicated wall fitting). Air in the system can damage the pump through dry running and overheating.

Before installing the cleaner, understand cleaner coverage:

The cleaner is designed to rid your pool of debris in approximately 4-6 hours. Less time could be needed, depending on the pool size.

The cleaner was not designed to automatically clean steps or swimouts or to work under a solar cover. It was also not designed to do initial cleanup for a new pool or when opening your pool for the season.

⚠ WARNING **Suction entrapment, injury, and drowning hazard. If your pool has a dedicated suction port ("vac port") for vacuuming or for an automatic pool cleaner, it must be covered when not in use.** Purchase a spring loaded safety cover from your local pool store and install it on the suction port to prevent entrapment and injury.

ABOUT INSTALLATION

Please use the convenient, water resistant, **"EASY-STEPS"** card.

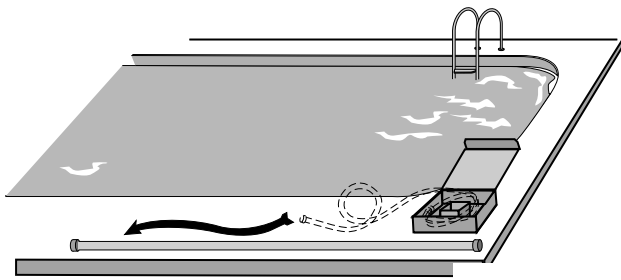

Figure 1

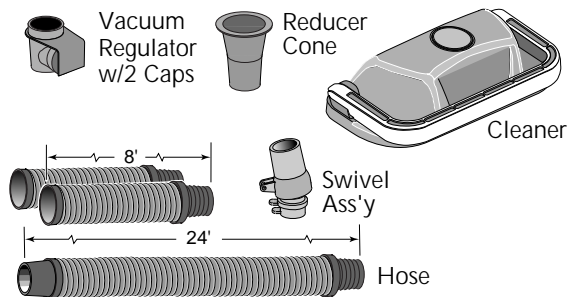

Figure 2

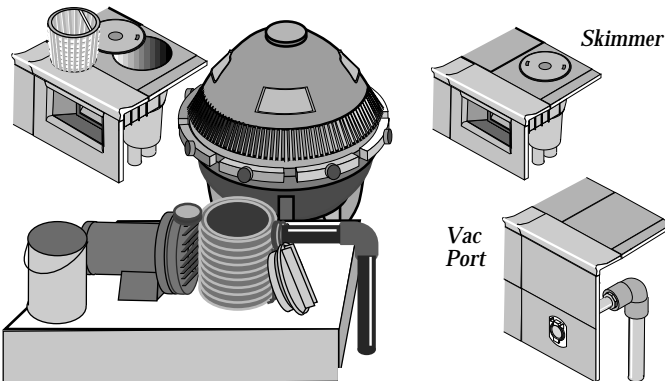

Figure 3

Figure 4

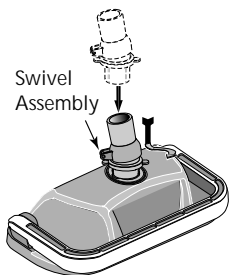

Figure 5

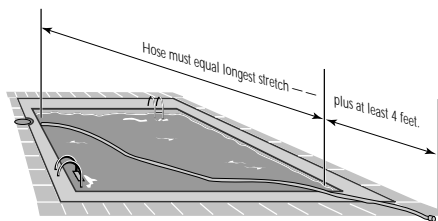

Figure 6

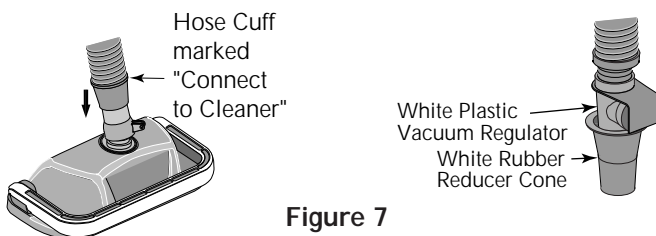

Figure 7

Step 1: Straighten hose (Figure 1)

Remove and uncoil the hose from the carton. Lay it out in the sunlight, flat and straight.

Step 2: Check parts (Figure 2)

Cleaner, black plastic swivel assembly, white rubber reducer cone, one 24' and two 8' hoses, white plastic vacuum regulator, extra black regulator cap marked "50".

Step 3: Clean filter system (Figure 3)

Backwash and clean filter; rinse; clean all baskets, etc. Start pump.

Step 4: Adjust valves for vacuuming (Figure 4)

Decide on the vacuum connection you are going to use (either a skimmer or a dedicated wall fitting) and adjust the pump valves (if your system has valves) to direct all vacuum there.

Close the main drain (also see "About Fine Tuning the Vacuum", Page 4)

Step 5: Assemble cleaner (Figure 5)

Insert swivel assembly into cleaner; twist 1/4 turn.

Step 6: Measure hose length needed (Figure 6)

Before connecting the hose, lay it out from the vacuum connection you are using (whether skimmer or dedicated wall fitting) to the furthest point of the pool. The hose should be at least 4' longer than this. More than 4' longer is OK. *Do not cut the hose.*

Step 7: Connect hose to cleaner (Figure 7)

Connect the 24' hose end marked "connect to cleaner" to the black swivel assembly. Connect the white plastic vacuum regulator to the opposite end of the hose. Insert the regulator into the white rubber reducer cone.

Step 8: Connect hose to filter system (Figure 8)

Fill the cleaner and hose with water and connect to the suction source. The cleaner will begin to operate.

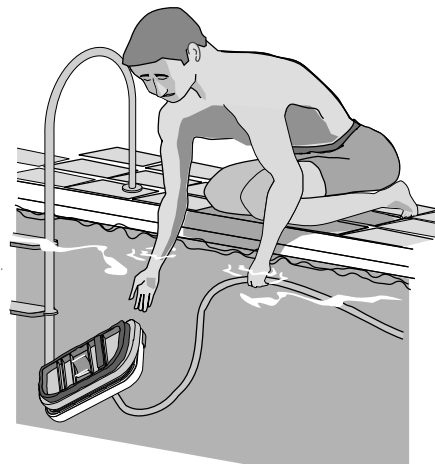

Figure 8

ABOUT THE CLEANER OPERATION:

Clicking sound

This sound is the oscillator moving back and forth in the oscillator chamber. The best speed for it is about 500 oscillations per minute. The vibration created by the oscillator moves the bristles and the cleaner. If the oscillator is running too fast, the cleaner will have a tendency to climb up the pool wall past the waterline, or “walk out of the pool”.

Movement around the pool

Random motion – The cleaner will visit most spots in the pool in a 6 hour period. It is not specifically programmed and cannot see the dirt you are seeing. It is a random motion cleaner.

The cleaner was designed to spend most of its time in the deep end, where most of the floor and wall area exists. During a 6 hour period the cleaner will visit the

shallow end a few times.

Rotating motion – The cleaner will rise up on one side and pivot a few times per minute. This is normal and provides the following:

1. Allows leaves that are being pushed or dragged along to be sucked up into the vacuum chamber.
2. Allows the cleaner to:
 - Change direction
 - Get out of corners
 - Get away from ladders
 - Submerge below pool water level
 - Get off of domed main drain covers

Picks up big “stuff”

The cleaner will pick up some debris so large that it may jam. Simply stop the pump and remove the debris from the oscillator or the swivel assembly.

ABOUT “FINE-TUNING” VACUUM ADJUSTMENTS AND CONNECTIONS:

⚠ WARNING Pool pump suction is hazardous and can cause entrapment with severe personal injury or drowning. Use vacuum regulator (see instructions below) in pool cleaner system unless pool cleaner will not operate with regulator installed.

Note: Each pool’s hydraulic system and vacuum connections are different. Be sure you have installed the **white plastic vacuum regulator** before you “fine-tune” the system. This not only regulates vacuum, but also acts as a safety device.

⚠ WARNING Suction entrapment, injury, and drowning hazard. If your pool has a dedicated suction port (“vac port”) for vacuuming or for an automatic pool cleaner, it must be covered when not in use. Purchase a spring loaded safety cover from your local pool store and install it on the suction port to prevent entrapment and injury.

For the “**NOVICE POOL OWNER**” where vacuuming is a new experience, please read all of the following points, installation instructions, and trouble shooting guide carefully.

Please note the following:

- “*Vacuum*” and “*suction*” are two words meaning the same thing.
- “*Dedicated suction line*”, “*vac port*”, and “*vac fitting*” are different terms for a hole in the side wall of pool; this hole is connected to the pump suction and is dedicated to vacuuming.
- Some pools do not have a vac port. If your pool does have one, please read the “Suction Entrapment” warning at left.



For the “**SEASONED POOL OWNER**”: The automatic pool cleaner connection and vacuum adjustments can be similar to using your manual pool vacuum. Please read on.

Valves (pump, skimmer, and main drain) and vacuum adjustments

You may need to spend some time adjusting the skimmer and main drain valves in order to obtain the best vacuum setting for good cleaner operation. Once you have found the correct valve settings for best operation, we suggest you mark the valves to ensure repeated success.

At first, set valves to give maximum vacuum to the skimmer or vac fitting you have elected to use.

ABOUT “FINE-TUNING” VACUUM ADJUSTMENTS AND CONNECTIONS:

Too much vacuum ?

You have too much vacuum if the cleaner climbs up the pool wall past the water line to the point that the cleaner sucks air and the pump loses prime. Frequent loss of prime will damage the pump. To correct this, change the black vacuum regulator cap marked “60” to the one provided in your accessory bag marked “50”. If the cleaner still climbs out and sucks air, open the main drain valve slightly.

Not enough vacuum ?

You don't have enough vacuum if the cleaner moves sluggishly or not at all. Be sure the filter system is clean and all valves are adjusted to give you maximum vacuum. If the cleaner is still not moving, your pump may not be strong enough to operate the cleaner. Also, please refer to the Troubleshooting guide on Page 7.

In-Line leaf canisters

If your pool is exposed to large quantities of leaves, we suggest purchasing and installing an in-line leaf canister. A leaf canister will provide more debris-loading capacity and also provides a water by-pass when the canister is full. It is very important that the pump not starve for water!

Dedicated suction line/vac port/vac fitting

Some pools have a dedicated wall fitting just for vacuuming. If the wall fitting connection is used, you may notice that the clear pump lid shows signs of bubbles or what appears to be the presence of air. To eliminate this, slightly open the main drain valve to supplement the water intake. The cleaner may slow down a bit when you change the suction.

Skimmer connection

Some pool owners remove the skimmer basket and connect the hose directly into the bottom of the skimmer. This method is OK for pools with minimal debris and also for screened in pools.

For pools that have large quantities of “big stuff” to pick up, we suggest using the bottom of the skimmer connection in conjunction with an in-line leaf canister (purchase the canister locally). A leaf canister will provide more debris-loading capacity and also provides a water by-pass when the canister is full. *It is very important that the pump not starve for water!*

Skimmer vac plates

Some pool owners connect the hose to a skimmer vac plate, which allows the skimmer basket to remain in the skimmer. If this method is used, empty the basket frequently. Also make sure that the vacuum regulator provided is completely submerged so that it will not suck air and damage the pump.

Skimmer vac plate vacuum control adjusters

Some pool owners use one of a variety of manufacturer's skimmer vac plates. Some have a vacuum control adjuster, and some do not. The adjuster could be a screw-type, a spring loaded apparatus, or a dial design. For those vac plates with adjusters, it is important to adjust them when fine tuning the vacuum for the cleaner.

If you have any questions, please call 1-800-752-0183

ABOUT THE CLEANER AND ACCESSORIES:

Swivel assembly (Figure 9)

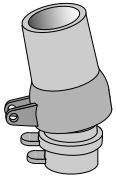

Figure 9

Installing the swivel assembly is a snap. Just insert it into the cleaner body and give it a quarter turn.

If you attach a unidapt handle to the swivel for manual vacuuming, be sure it is the special, floating unidapt handle provided with the cleaner (Replacement Part No. GW9019). Use of a different

unidapt handle will hinder the cleaner's performance.

Hoses (24' and two 8' lengths – Figure 10)

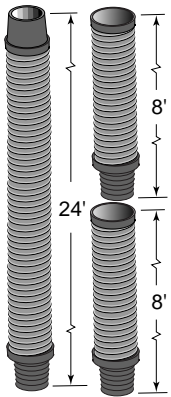

Figure 10

The unit includes a 24' hose and two 8' extensions. Do not cut any of these hoses.

The best hose length is at least 4' longer than the distance from your suction source (whether skimmer or dedicated suction line) to the furthest point in the pool. If the hose seems to be too long, remove the 8' section provided. Do not cut the 24' hose.

Be sure to connect the tapered end of the 24' hose (marked "connect to cleaner") to the cleaner head.

If additional hose is needed, use only the specially designed 8' extension hose from your Sta-Rite dealer (order replacement part No. GW9511). Use of another manufacturer's hose will hinder cleaner coverage (this also holds true for the 24' hose). If you need to replace the 24' hose, buy only the original equipment hose (order replacement part No. GW9525).

Hose (6" connector) female x female (purchase accessory No. GW9021) If required, this will accommodate a male x male connection at the skimmer.

Reducer cone (Figure 11)

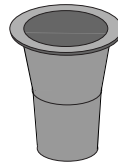

Figure 11

The reducer cone is required to make most hose connections. When used, it will keep the hose in place if the filter system is stopped.

Automatic vacuum regulator (Figure 12)

▲ WARNING Hazardous suction. Can cause entrapment with severe personal injury or drowning.

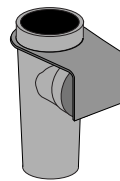

Figure 12

Vacuum regulator should be installed in all situations. If the cleaner moves very slowly or not at all (indicating low vacuum in the system), see Troubleshooting Chart, Page 7. The regulator includes two black rubber regulator caps. One is installed on the regulator at the factory, and one is in the accessory bag. The cap marked "50" in the accessory bag is for systems with extremely high vacuum. Use of this cap will help prevent the cleaner from "walking" out of the pool.

Make sure the vacuum regulator, especially the black rubber cap, is submerged at all times. If not, the pump will suck air through the regulator and lose prime. *This could damage the pump.*

ABOUT BUMPER INSERTS

Bumper Inserts (see Key 2A, Page 10) help to make the cleaner more buoyant to allow better access to the shallow end of the pool. Do not install inserts from the top; they will become jammed and not work properly. Only install inserts from the bottom.

If the bumper on the cleaner appears to lift the cleaner to the surface of the pool, check for trapped air in the

cleaner and hose. If no air is found, remove one bumper insert block and watch and see if the cleaner remains submerged and on the pool floor while working. If not, remove individual insert blocks as needed until the cleaner rests on the pool floor and operates properly.

ABOUT TROUBLESHOOTING

SITUATION	SOLUTIONS:
Cleaner does not move. Oscillator is very slow.	<ol style="list-style-type: none"> 1. Backwash and/or clean filter. Empty all baskets. This should help your cleaner attain the desired oscillation rate of 400-600 times per minute. 2. Clear all debris from oscillator chamber, hose, or vac plate by-pass (if you have one). 3. Repair all sources of vacuum leaks (cracked vac plate, vac plate or reducer cone not seated properly, cracked hose, vac plate by-pass adjusted too loosely). 4. Adjust valves to give maximum vacuum to the vacuum port or skimmer to which you are attaching the cleaner hose. Reduce or shut off other skimmers and main (floor) drain. Note: Each pool's hydraulic system is different. It may require some adjustments to skimmer and main valves before you achieve the vacuum setting required for the best cleaner to operation. Once determined, mark the valves at that position to ensure repeated success. 5. Filtration system (pump) does not develop enough vacuum. Consult your pool service professional. 6. In hot water, the hose may kink. The hose, when old, may have developed leaks (cracks or holes) or may get brittle. Purchase a new hose. NOTE: It must be a Sta-Rite hose for proper operation.
Cleaner climbs past water line of pool causing pump to lose prime (suck air).	<ol style="list-style-type: none"> 1. Oscillator is running too fast. Install vacuum regulator if you have not already done so. 2. If regulator is installed and cleaner still climbs out of the pool (sucking air), remove the black rubber regulator cap and replace it with the cap marked #50 from the accessory bag. 3. If steps 1 and 2 do not solve the problem, slightly open the main drain valve until the cleaner no longer climbs out of the pool.
Cleaner coverage not as expected.	<ol style="list-style-type: none"> 1. A clean filter system will help the cleaner to move much faster. Also, be sure to clean all baskets. 2. Vinyl liner pools with a deep end hopper will require 6-8 hours to clean. In this time the cleaner should make at least 4 trips to the shallow end. If not, call Customer Service at 1-800-752-0183. 3. Examine the turning brush mechanism as the cleaner is operating. To do this, you will have to turn the cleaner over while it is running and submerged. If the turning brush does not move to the "down" position within 2 minutes, call Customer Service at 1-800-752-0183. 4. The cleaner was not designed to work under solar covers. If you have a solar cover, only minimal coverage can be expected. 5. At times strong winds may hinder cleaner coverage! 6. Any cleaner might miss a spot. Your cleaner has been designed to accommodate the attachment of a vac-pole (telepole) by use of the handle in the accessory bag. Attach pole for spot cleanups, steps, and swimouts.
Cleaner "stuck" in one spot (more than 15 minutes).	<ol style="list-style-type: none"> 1. Examine the turning brush mechanism as the cleaner is operating. To do this, you will have to turn the cleaner over while it is running and submerged. If the turning brush does not move to the "down" position within 2 minutes or less, call Customer Service at 1-800-752-0183.
Steps and "swim-outs" are not clean.	<ol style="list-style-type: none"> 1. This cleaner was not designed to clean these areas. Use the handy telepole attachment, connect the pole, and clean missed areas.
Cleaner flips on its back when pump stops.	<ol style="list-style-type: none"> 1. This is normal with some filter systems that develop a surge of back pressure when the system shuts off. The cleaner will right itself when the system is restarted.
Hose comes loose when pump stops.	<ol style="list-style-type: none"> 1. Use reducer cone when connecting to the skimmer or vac port.
Cleaner hovers in one area with hose fully extended.	<ol style="list-style-type: none"> 1. Hose might be too short. Desired length can be measured from the point where the hose is connected, to the furthest point of the pool, plus a minimum of an additional 4'. If needed, purchase an 8' extension hose (part No. GW9511) from your local dealer. Do not cut extension hose – use it full length even if it is a little long.
Hose keeps coiling up.	<ol style="list-style-type: none"> 1. For best results, when hose is not in use, store it uncoiled, flat, and straight. If coiling is necessary, coil loosely. 2. Lay hose out flat and straight in the sunlight for a few hours prior to use.

If you have any questions, please call 1-800-752-0183

ABOUT DISASSEMBLY

1. Remove swivel assembly (Figure 13) from the top of the cleaner by turning it 1/4-turn counterclockwise and pulling straight up on it.
2. Turn cleaner upside down. Remove 4 screws and remove lower body assembly from shroud.
3. Turn lower body assembly right side up. Unsnap the 2 clips on the oscillator chamber cap (Figure 14A); lift it off.
4. Pull the long gear shaft straight up (Figure 14A) by the blocks on the ends of the shaft. Hold the seals in the oscillator and the blocks on the shaft. The cam may interfere with the shaft mounting post; if so, turn it slightly on the shaft until it clears the post. The shaft assembly can now be disassembled (Figure 14B).
5. Slide the long gear shaft out of the oscillator (with gears, complete); make sure that you don't lose the seals out of the oscillator which may fall out at this point (Figure 14B).
- 5A. Oscillator seals are replaceable.
- 5B. Ratchet gear set and long shaft are replaceable as a unit.
6. Remove the short gear shaft and gears (Figure 15); do not lose the gears off of the shaft.

NOTE: Put one finger under the gear nearest the end of the cleaner and lift straight up to remove the short gear shaft. Do not twist or bend the shaft.
7. With a small screwdriver (such as a jeweler's screwdriver), a pencil, or a pen point, depress and remove the coil spring from the movable brush mounting post (Figure 16). Replace the brush and the spring if necessary.
8. The metal ratchet tab slides out of its slot sideways; replace it by removing the center brushes and sliding in a new ratchet tab until it is flush with the edge of plastic holder (Figures 17 and 18). Replace the center brushes.
9. The brush ring pops out of the cleaner body for easy replacement.
10. If you need to replace the bumper, turn the shroud and bumper assembly upside down and remove the two screws holding the bumper to the shroud.

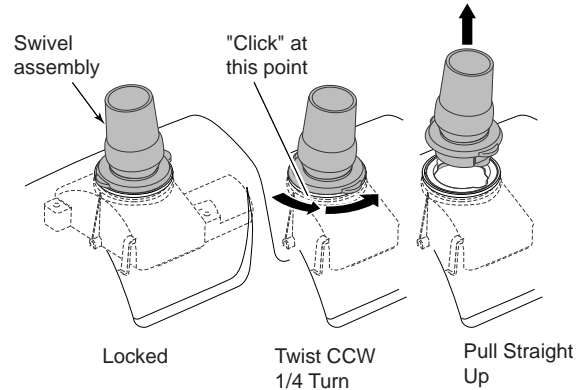

Figure 13

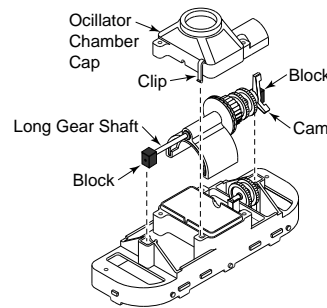

Figure 14A

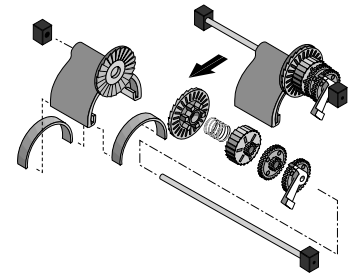

Figure 14B

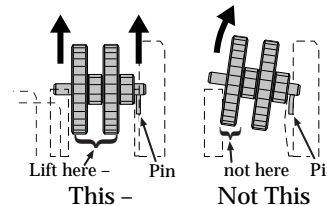

Figure 15

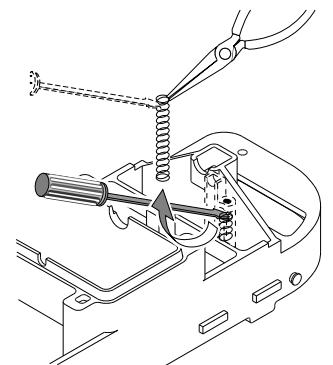

Figure 16

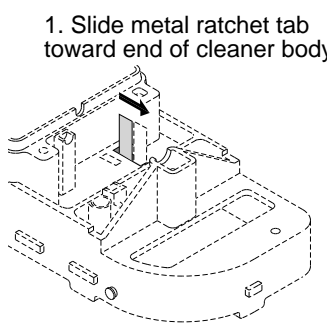

Figure 17

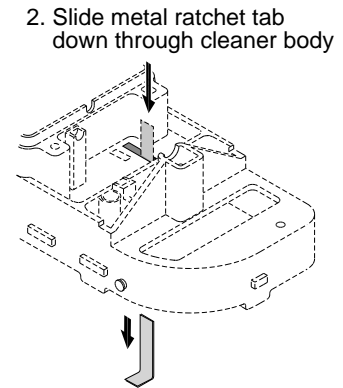

Figure 18

If you have any questions, please call 1-800-752-0183

ABOUT ASSEMBLY

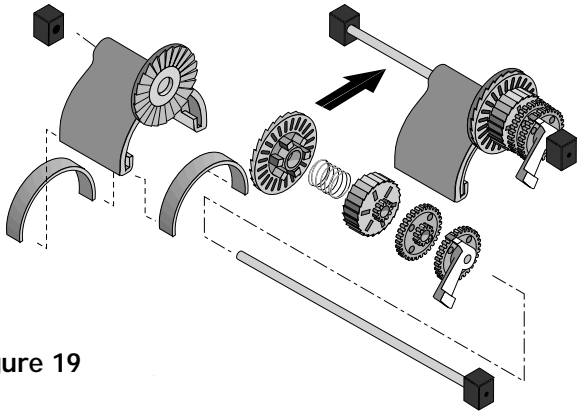

Figure 19

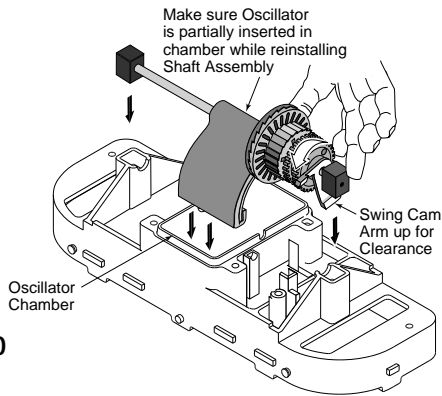

Figure 20

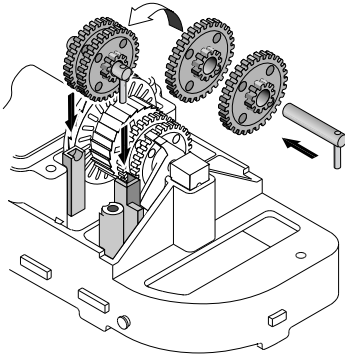

Figure 21

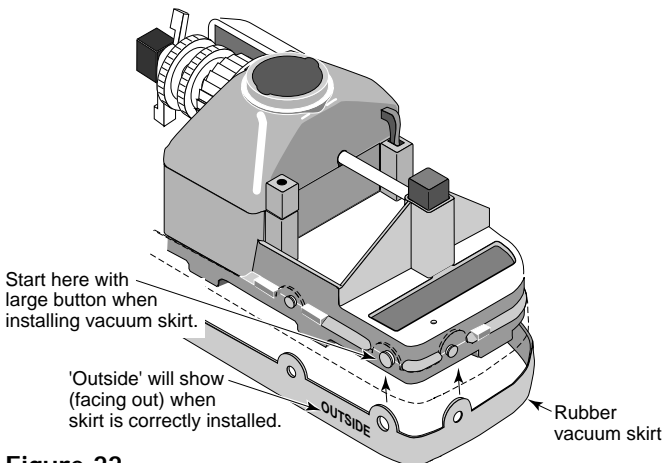

Figure 22

1. Put both white seals in the oscillator; hold them in place.
 2. Install the oscillator on the long gear shaft. Install the ratchet gear on the shaft so that the teeth engage the ratchet on the oscillator. Install the spring, ratchet drum, pinion gear (large gear first), and cam (gear end first) on the shaft (See Figure 19). Hold the gears on the shaft while installing them, and compress the clutch spring to allow assembly to slip into place between the posts (See Figure 19).
 3. Install the long gear shaft and end blocks in the cleaning head with the large arm of the cam down (see Figure 20).
 4. Reinstall the short gear shaft and two gears (See Figure 21); the small pinion gears and the shaft pin go on the side toward the *end* of the cleaner – away from the oscillator box. Make sure that the gears engage the gears on the long gear shaft.
 5. Install the oscillator chamber cap and clip it in place.
 6. Install the rubber vacuum skirt on the cleaner with the word 'OUTSIDE' showing. Start at the large pin on the back of the cleaner head (see Figure 22) and work around the cleaner. Make sure the skirt is flush against the stop strips on the cleaner head (see Figure 23).
 7. Turn the cleaner over. If you removed the bumper and brush ring, replace them now.
 8. Install the lower body assembly in the shroud. Fasten the cleaning head in place with 4 screws (2 long, 2 short – see Figure 24).
- NOTE:** Make sure that you do not dislodge the rubber vac skirt while inserting the lower body assembly past the brush ring.

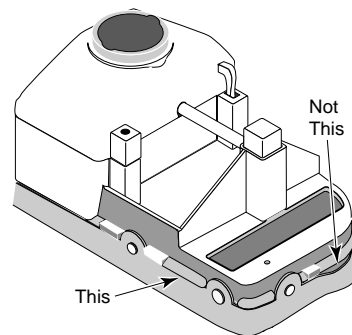

Figure 23

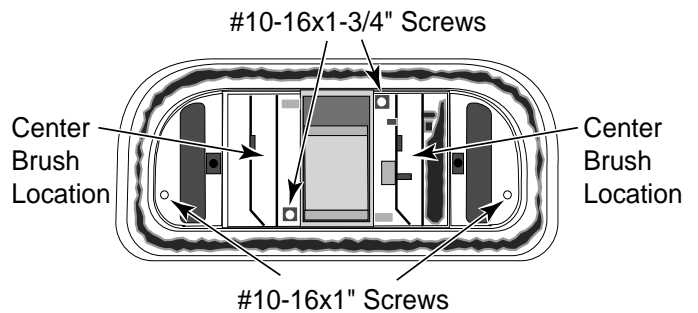
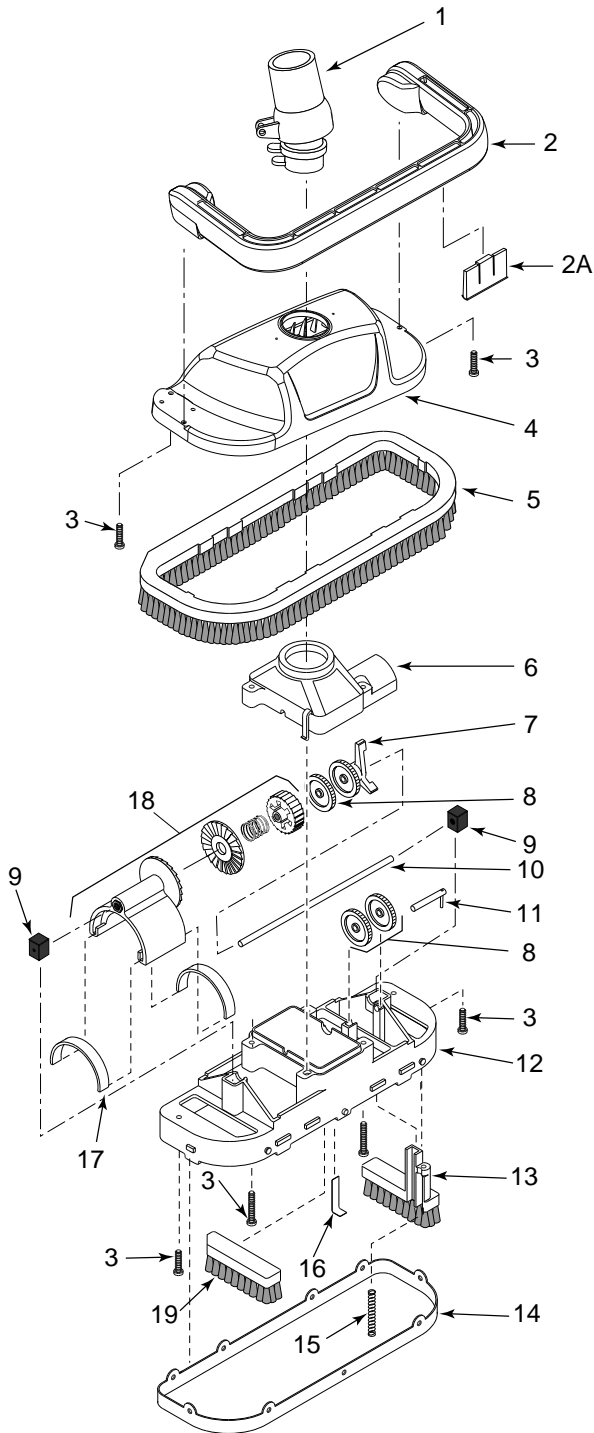

Figure 24 Bottom View of Cleaner

If you have any questions, please call 1-800-752-0183

Repair Parts



Optional Accessories

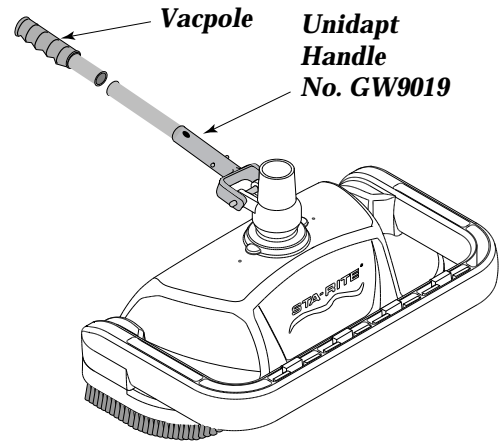

Key No.	Part Description	Part No.
1	Swivel Assembly	GW9012
2	Bumper	GW9502
2A	Bumper Insert Kit (Set of 4)	GW9520
3	Screw Kit (4 short, 2 long)	GW9509
4	Shroud	GW9501
5	Brush Ring	GW9505
6	Oscillator Chamber Cap	GW9506
7	Cam Kit (2 & 3 Leg Cams)	GW9507
8	Idler Gear Kit (Incl. 3 Gears)	GW9509
9	Block Kit (Incl. 2 Blocks)	GW9512
10	Long Gear Shaft (Stainless Steel)	GW9513
11	Short Gear Shaft (Stainless Steel)	GW9529
12	Lower Body*	GW9515
13	Lift Brush	GW9517
14	Vacuum Skirt	GW9508
15	Lift Brush Spring	GW9522
16	Ratchet Tab (Stainless Steel)	GW9523
17	Oscillator Seal Kit (Incl. 2 Seals)	GW9004
18	Oscillator Assembly Kit (Incl. Key #17) (Ratchet Ass'y not sold separately)	GW9503
19	Center Brush Kit (Set of 2)	GW9013
	• 24' Vacuum Hose	GW9525
	• 8' Vacuum Hose Extension (1/pkg.)	GW9511
	• Vacuum Regulator Assembly	GW9016
	• Vacuum Regulator Cap Kit (Includes #50, #60, #70 Caps)	GW9018
	• Reducer Cone	GW9015
	• Unidapt Handle	GW9019
	• 6" Female to Female Adapter Hose**	GW9021

- Not illustrated.
- * Includes Key Nos. 6, 11, 13, 15, 16, two idler gears and 2-arm cam.
- ** Accessory - purchase separately.

If you have any questions, please call 1-800-752-0183

ABOUT MAINTENANCE AND CARE

▲ WARNING Hazardous suction. Stop pump before attempting to clean pool cleaner.

- Keep skimmer basket and pump strainer basket clean and free of debris.
- If cleaner jams with large debris (leaves, sticks, etc.), try cleaning debris first from bottom of unit. If this doesn't clear unit, remove top swivel assembly (turn 1/4 turn) and clear the debris from the top.
- Remove the pool cleaner from the pool before super chlorinating (shocking) or chemical balancing. Wait at least four hours after the chemical procedure before reinstalling the cleaner.
- Make sure that the cleaner's brush bristles don't become deformed during storage. Store the unit so that it doesn't sit on the bristles and so that nothing compresses them.
- If possible, do not coil the hose. Remove the hose from the cleaner when removing the cleaner from the pool. Store the hose flat and straight.
- Periodically examine bristles and vacuum skirt for wear or distortion. Replace if necessary. See "Assembly", Page 9.
- If necessary to remove oscillator, see "Disassembly", Page 8.
- Don't store the cleaner with the hose connected to the cleaner body or with the hose coiled. To do so will cause the hose to take a set or kink over a period of time. When reinstalled in the pool, the hose will tend to stay coiled and will cause the cleaner to malfunction.
- If the hose has taken a set, uncoil it as far as possible without damaging it and lay it out in the sun for several hours to straighten itself. Once it has relaxed and straightened out, store it laid out flat and straight (no coiling) if possible. If no storage area is available that will allow this, coil the hose as loosely as possible and expect to have to let it straighten for a while before using the cleaner again.
- Make sure the lift brush is retracted during storage or else that the cleaner is supported such that the lift brush is not taking any of the cleaner's weight. If the lift brush is down during storage and the cleaner rests on it, the brush bristles will collapse over time and the cleaner will no longer turn during operation as it was designed to do.

HOSE STORAGE

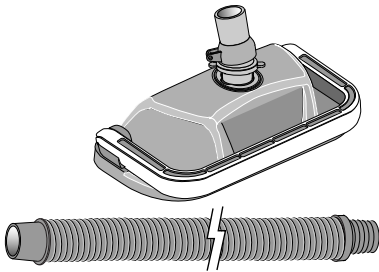

Best: Hose stored correctly – laid out straight, not connected to cleaner.

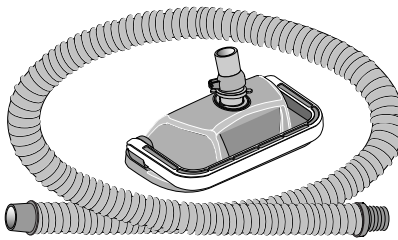

OK, Not Recommended: Hose is disconnected from cleaner and loosely coiled (no sharp bends).

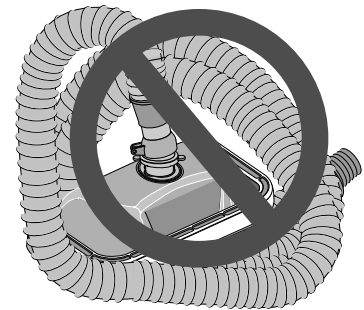

Wrong: Storing cleaner with hose connected will damage hose and void the hose warranty.

STA-RITE LIMITED WARRANTY

Pumps, filters, skimmers, underwater lights (except bulbs), accessories and fittings manufactured by Sta-Rite are warranted to be free of defects in material and workmanship for one (1) year from date of installation.

Product specific warranties:	Year from date of installation
<i>HRPB, DEPB and System 3</i> – Tanks	10 years
Internal filter components and valves	1 year
<i>Max-E-Therm</i> – Pool/Spa Heaters	2 years
Heater Enclosure only (Upper RH & LH; lower enclosure; and control board enclosure)	10 years
<i>Automatic Pool Cleaners including Hose</i>	2 years
<i>Cristal-Flo filters</i> – Tanks	10 years pro-rated*
Valve and internal components.	1 year
<i>Posi-Flo II</i> – Tanks	10 years
Elements	1 year
<i>Waterford Sand</i> – Tanks	10 years pro-rated*
Pumps	1 year
Valve and Internals	1 year
<i>Waterford Cartridge</i> – Filter Tank	10 years
Pumps	1 year
<i>System 3 Above Ground Systems</i> – Tanks	10 years
Pumps	1 year
Platform and Internals	1 year
<i>Pumps</i>	1 year
When equipped with A.O. Smith 2-compartment motors (Does not include pumps sold as part of a systems package)	2 years

* Full warranty coverage is in effect for one year after installation. The pro-rated warranty covers the *tank only* during

the 2nd through 10th year after installation. The amount covered decreases by 10% each year. (ie., 2nd year 90% covered, 3rd year 80% covered, etc.).

The foregoing warranties relate to the original consumer purchaser ("Purchaser") only. Sta-Rite shall have the option to repair or replace the defective product, at its sole discretion. Purchasers must pay all labor and shipping charges necessary to replace the product covered by this warranty. Requests for warranty service must be made through the installing dealer. This warranty shall not apply to any product that has been subject to negligence, misapplication, improper installation or maintenance, or other circumstances which are not in Sta-Rite's direct control.

This warranty sets forth Sta-Rite's sole obligation and Purchaser's exclusive remedy for defective products.

STA-RITE SHALL NOT BE LIABLE FOR ANY CONSEQUENTIAL, INCIDENTAL OR CONTINGENT DAMAGES WHATSOEVER.

THE FOREGOING WARRANTIES ARE EXCLUSIVE AND IN LIEU OF ALL OTHER EXPRESS WARRANTIES. IMPLIED WARRANTIES, INCLUDING BUT NOT LIMITED TO THE IMPLIED WARRANTIES OF MERCHANTABILITY AND FITNESS FOR A PARTICULAR PURPOSE, SHALL NOT EXTEND BEYOND THE DURATION OF THE APPLICABLE EXPRESS WARRANTIES PROVIDED HEREIN.

Some states do not allow the exclusion or limitation of incidental or consequential damages or limitations on how long an implied warranty lasts, so the above limitations or exclusion may not apply to you. This warranty gives you specific legal rights and you may also have other rights which vary from state to state.

Supersedes all previous publications.

Sta-Rite Industries, Inc.
293 Wright Street
Delavan, WI 53115

▲ Retain Warranty Certificate (upper portion) in a safe and convenient location for your records.

DETACH HERE: Fill out bottom portion completely and mail within 10 days of purchase/installation to:
 ▼ Sta-Rite, Attn: Warranty Dept., 293 Wright St., Delavan, WI 53115



Warranty Registration Card

Name _____

Address _____

City _____ State _____ Zip _____

Purchase Date _____

Product Purchased _____

New installation Replacement

Type of Pool Inground Vinyl Fiberglass Gunite

Size of Pool _____

Years pool has been in service less than 1 1-3 3-5 5-10

Purchased from:
 Company name _____

Address _____

City _____ State _____ Zip _____

Please send me more information on these other products from Sta-Rite.

Pumps Filters Automatic Pool Cleaners
 Maintenance Equipment Test Strips
 Heaters