

# 'U' STYLE DIVING FRAMES

UF-12-100 UF-18-101  
UF-18-102 UF-24-102 UF-24-103



## CAUTION

ALL MINIMUM WATER ENVELOPE DIMENSIONS FOR RESIDENTIAL INGROUND SWIMMING POOLS MUST MEET THE ANSI/NSPI-5 2003 AMERICAN NATIONAL STANDARD FOR RESIDENTIAL INGROUND SWIMMING POOLS (REFERENCED THROUGHOUT THESE ASSEMBLY AND INSTALLATION INSTRUCTIONS AS "ANSI/NSPI-5 2003"). ALL WATER ENVELOPE DIMENSIONS FOR PUBLIC SWIMMING POOLS MUST MEET THE ANSI/NSPI-1 2003 STANDARD FOR PUBLIC SWIMMING POOLS (REFERENCED THROUGHOUT THESE ASSEMBLY AND INSTALLATION INSTRUCTIONS AS "ANSI/NSPI-1 2003"). COMPLY WITH LOCAL GOVERNMENT REGULATIONS IF THEY EXCEED ANSI/NSPI STANDARDS.

All diving boards and related equipment are manufactured for inground swimming pools ONLY. The S.R. Smith "U" Style Diving Frames are designed to be easily transported and installed. Follow all instructions carefully and inspect closely to assure proper and safe installation.

PROPER INSTALLATION CANNOT BE OVERSTATED. IMPROPER INSTALLATION VOIDS S.R. SMITH'S WARRANTY AND MAY AFFECT THE SAFETY OF THE USER.

# S.R. Smith LLC™

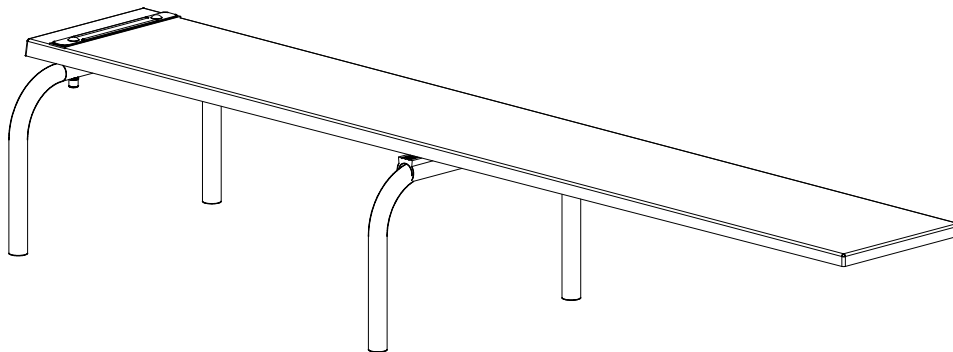

**WESTERN SALES AND MANUFACTURING PLANT  
CORPORATE HEADQUARTERS**

P.O. Box 400 • 1017 S.W. Berg Parkway  
Canby, Oregon 97013  
Phone (503) 266-2231 • Fax (503) 266-4334  
[www.srsmith.com](http://www.srsmith.com)



**ATTENTION!**  
**THESE INSTRUCTIONS MUST REMAIN WITH STAND OWNER**

# ‘U’ STYLE DIVING FRAMES STAINLESS STEEL

For Residential and Commercial Diving Boards

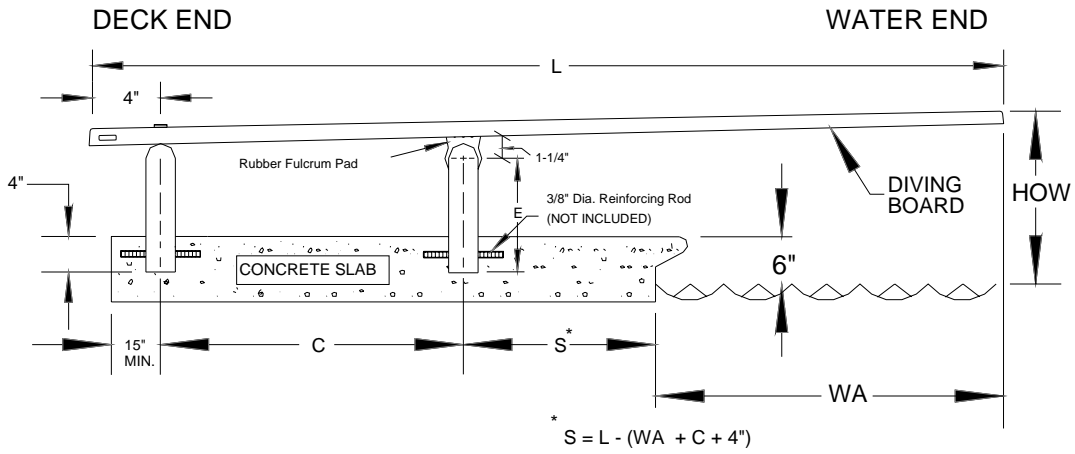

S.R. SMITH CANNOT GUARANTEE CUSTOMER'S CONCRETE OR THICKNESS RECOMMENDED Compressive strength of concrete is 3500 psi or greater.

SLAB THICKNESS = 6" (MIN.) WIDTH = 4' (MIN.)

| U FRAME   | E      |
|-----------|--------|
| UF-12-100 | 12.00" |
| UF-18-101 | 18.00" |
| UF-18-102 | 18.00" |
| UF-24-102 | 24.00" |
| UF-24-103 | 24.00" |

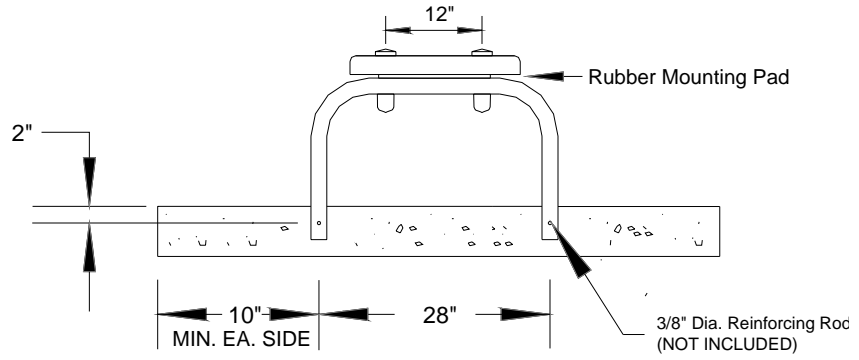

## HEEL END VIEW

FIG. 1

## INSTALLATION CHART

Refer to Fig. 1

| Diving Board | Fulcrum Setting<br>C | Actual Length<br>L* |
|--------------|----------------------|---------------------|
| 6'           | 30" ± 3              | 70-1/2"             |
| 8'           | 40" ± 4              | 94-1/2"             |
| 10'          | 52" ± 5              | 118-1/2"            |
| 12'          | 62" ± 6              | 142-1/2"            |
| 14'          | 74" ± 6              | 166-1/2"            |
| 16'          | 86" ± 6              | 190-1/2"            |

\* Add 1-1/2" to L dimension for Aluminum Diving Boards

## 'U' STYLE DIVING FRAMES INSTALLATION CHART RESIDENTIAL SWIMMING POOLS

Refer to Fig.1

FOR PUBLIC POOLS  
SEE PAGE 5

| ANSI/NSPI-5<br>2003<br>Pool Type | Max. Diving<br>Board Length | Max. Board Height<br>Over Water<br>"HOW" | Min. Overhang<br>WA ± 3" |
|----------------------------------|-----------------------------|--|--------------------------|
| I                                | 6'                          | 20"                                      | 18"                      |
| II                               | 8'                          | 20"                                      | 18"                      |
| III                              | 10'                         | 26"                                      | 24"                      |
| IV                               | 10'                         | 30"                                      | 30"                      |
| V                                | 12'                         | 40"                                      | 36"                      |

\*WA DIMENSION IS VALID ONLY IN CONJUNCTION WITH MIN. DEPTH AT POINT A (SEE ANSI/NSPI-5 2003 FIGURE 3 AND TABLE 1) FOR POOL TYPE.

---

## INSTALLATION INSTRUCTIONS

---

**CONCRETE DECK AROUND 'U' FRAMES MUST BE 6" THICK MINIMUM.**

1. READ CAREFULLY the following, and pages 6 through 10, which have been extracted from ANSI/NSPI-5 2003 and pay particular attention to Figure 3 and Table 1 set forth therein.
2. Determine positioning of 'U' Frames by using formula  $S = L - (WA + C + 4")$  in Fig. 1.
3. Both 'U' Frames must be leveled left to right and to each other when installing. This will allow the diving board to sit level left to right and have a slight upward pitch at the toe end once the rubber fulcrum pad is in place.
4. When mounting a diving board to a newly installed stand with a permanently fixed fulcrum, the correct measurement between the mounting holes and the fulcrum must be maintained so as not to void warranty. (See INSTALLATION CHART)
5. The Rubber Fulcrum Pad MUST be used so as not to void S. R. Smith's warranty.
6. A rubber mounting pad MUST be installed between the bottom of the diving board and the Heel End 'U' Frame as not to void S. R. Smith's warranty.

---

**CAUTION: ONLY ONE PERSON ON A DIVING BOARD AT A TIME, WITH A MAXIMUM WEIGHT OF 250 LBS.**

---

7. **IMPORTANT:** Refer to Table 2. Maximum diving board length, maximum height over water at point A and minimum cross section dimensions at point A and B shall be in accordance with Table 2 and Fig 3.

**Table 2- S.R. Smith Residential Pool Specifications**

| Pool type | MAX. DIVING BOARD LENGTH              | MAX. HEIGHT OVER WATER AT POINT A | CROSS SECTIONAL DIMENSIONS AT POINT A |            | CROSS SECTIONAL DIMENSIONS AT POINT B |           |       |           |            |           |
|-----------|---------------------------------------|-----------------------------------|---------------------------------------|------------|---------------------------------------|-----------|-------|-----------|------------|-----------|
|           | DBL**                                 | HOW**                             | F                                     | G          | H                                     | J         | K     | L         | M          | N         |
| 0         | <b>DIVING EQUIPMENT IS PROHIBITED</b> |                                   |                                       |            |                                       |           |       |           |            |           |
| I         | 6' DB/6' JB                           | 20"                               | 2'-9"                                 | 5'-0"      | 4'-0"                                 | 7'-2 1/2" | 7'-6" | 6'-0"     | 3'-9"      | 2'-1 1/2" |
| II        | 8' DB/6' JB                           | 20"                               | 2'-9"                                 | 3'-10"     | 4'-2"                                 | 7'-2 1/2" | 7'-6" | 6'-8"     | 3'-9"      | 2'-1 1/2" |
| III       | 10' DB/8' JB                          | 26"                               | 2'-9"                                 | 4'-4 3/4"  | 4'-4 1/2"                             | 7'-5 1/2" | 8'-0" | 6'-7"     | 3'-11 1/2" | 1'-7 1/2" |
| IV        | 10' DB/8' JB                          | 30"                               | 2'-9"                                 | 5'-10 1/2" | 3'-10"                                | 7'-8"     | 8'-6" | 8'-3"     | 5'-7"      | 2'-7"     |
| V         | 12' DB/8' JB                          | 40"                               | 2'-9"                                 | 6'-2"      | 3'-11 1/2"                            | 7'-9 1/2" | 9'-0" | 8'-2 1/2" | 5'-9"      | 2'-1"     |

**NOTES:**

- ABBREVIATIONS: DBL=Diving Board Length, DB=Diving Board, JB=Jump Board, HOW=Height Over Water.
- IMPORTANT:** The walls of a Type I Pool, when defining the Maximum Diving Water Envelope shall be plumb.
- All dimensions are minimum, except where noted as maximum.
- One half (1/2) the width shown at each point shall be available on each side of the diving equipment centerline.
- Minimum water depth under tip of diving board (Point A) is important to maintain.

**FIG.3**

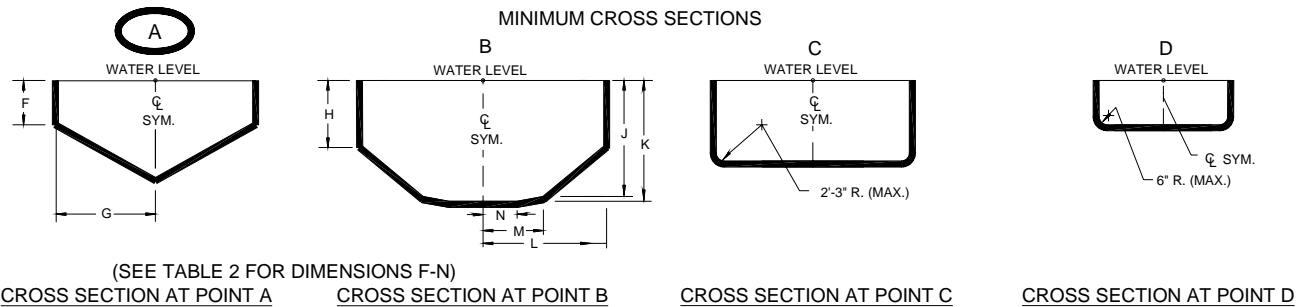

8. The top surface of the diving board from the deck end to the tip end shall be level or have an upward slope of 5/8" per foot (16 mm: 305mm) maximum. Elevation difference shall not exceed 6 inches (152mm) from the deck end to the tip of the board. There shall be no downward slope towards the water. The slope shall be measured using a level as shown in Fig. 4.

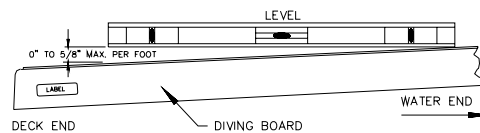

**FIG.4**

9. Minimum unobstructed headroom from the top of the manufactured diving equipment shall be provided for diving in accordance with Table 1.

| <b>TABLE 1<br/>MINIMUM HEADROOM ABOVE<br/>DIVING AREA</b> |                                       |
|---|---------------------------------------|
| Pool Type   | Minimum Headroom Above Diving Surface |
| I   | 12 feet (3.7 m)                       |
| II  | 12 feet (3.7 m)                       |
| III   | 13 feet (4 m)                         |
| IV  | 13 feet (4 m)                         |
| V   | 14 feet (4.3 m)                       |

**'U' STYLE DIVING FRAMES  
INSTALLATION CHART  
PUBLIC POOLS**  
Refer to Fig.1

FOR RESIDENTIAL  
POOLS SEE PAGE 3

| ANSI/NSPI-1<br>2003<br>Pool Type | Max. Diving<br>Board Length | Max. Board Height<br>Over Water<br>"HOW" | Min. Overhang<br>"L <sub>1</sub> " ± 3 |
|----------------------------------|-----------------------------|--|--|
| VI                               | 10'                         | 26" (2/3 Meter)                          | 30"                                    |
| VII                              | 12'                         | 30" (3/4 Meter)                          | 36"                                    |
| VIII                             | 16'                         | 1 Meter                                  | 48"                                    |
| IX                               | 16'                         | 3 Meter                                  | 72"                                    |

**\*L<sub>1</sub> DIMENSION IS VALID ONLY IN CONJUNCTION WITH MIN. DEPTH (D<sub>1</sub>) AT POINT A FOR POOL TYPE. (SEE ANSI/NSPI-1 2003 Figure 1 and Table 2)  
COMPLY WITH LOCAL GOVERNMENT REGULATIONS FOR PUBLIC SWIMMING POOLS IF THEY EXCEED THE ANSI/NSPI-1 STANDARD.**

**INSTALLATION INSTRUCTIONS**

**CONCRETE DECK AROUND 'U' FRAMES MUST BE 6" THICK MINIMUM.**

1. READ CAREFULLY the following, and pages 11 through 18, which have been extracted from ANSI/NSPI-1 2003 and pay particular attention to Figure 1 and Table 2 set forth therein.
2. Determine positioning of 'U' Frames by using formula  $S = L - (L_1 + C + 4")$  in Fig. 1. NOTE: WA is replaced by L<sub>1</sub> for public pools.
3. IMPORTANT: Refer to Table 3. Maximum diving board length and maximum height over water at point A shall be in accordance with Table 3.

**TABLE 3- S.R.SMITH PUBLIC POOL SPECIFICATIONS**

| Pool Type | RELATED DIVING EQUIPMENT |                            | Note: Placement of boards shall observe the following minimum dimensions. With multiple board installations minimum pool widths must be increased accordingly. |
|-----------|--------------------------|----------------------------|--|
|           | Max. Diving Board Length | Max. Board Hgt. Over Water |  |
| VI        | 10'                      | (2/3 Meter)<br>26"         | Deck Level Board to Pool Side<br>8'  |
| VII       | 12'                      | (3/4 Meter)<br>30"         | 1 Meter Board to Pool Side<br>10'  |
|           |                          |                            | 3 Meter Board to Pool Side<br>11'  |
| VIII      | 16'                      | 1 Meter                    | 1 Meter or Deck Level Board to 3 Meter Board<br>10'  |
| IX        | 16'                      | 3 Meter                    | 1 Meter or Deck Level to another 1 Meter or Deck Level Board<br>8'   |
|           |                          |                            | 3 Meter to another 3 Meter Board<br>10'  |

4. Both 'U' Frames must be leveled left to right and to each other when installing. This will allow the diving board to sit level left to right and have a slight upward pitch at the toe end once the rubber fulcrum pad is in place.
5. When mounting a diving board to a newly installed stand with a permanently fixed fulcrum, the correct measurement between the mounting holes and the fulcrum must be maintained so as not to void warranty. (See INSTALLATION CHART)
6. The Rubber Fulcrum Pad MUST be used so as not to void S. R. Smith's warranty.
7. A rubber mounting pad MUST be installed between the bottom of the diving board and the Heel End 'U' Frame as not to void S. R. Smith's warranty.

**ARTICLE 5 - POOL DIMENSIONS AND TOLERANCES**  
**EXTRACTED FROM ANSI/NSPI-5 2003**  
**AMERICAN NATIONAL STANDARD FOR RESIDENTIAL INGROUND SWIMMING POOLS**

**5.1 General requirements.** Design dimensions shall comply with specifications in this standard. The pool shall be constructed to these design dimensions within the tolerances listed in 5.1.1.

**5.1.1 Construction tolerances.** There shall be construction tolerances allowed on dimensional designs. The overall length, width and depth shall be limited to a tolerance of plus or minus 3 inches ( $\pm 7.6$  cm). All other dimensions shall be limited to a tolerance of plus or minus 2 inches ( $\pm 5.1$  cm), unless otherwise specified.

**5.2 Perimeter shape.** No limits are specified for shape of pools except that consideration shall be given to shape from the standpoint of circulation of the swimming pool water and safety to the user.

**5.3 Walls - requirements**

**5.3.1** Walls in the shallow area and deep area of the pool shall not slope greater than 11° (1:5 slope ratio) to a transition point. The transition point shall not be less than 2 feet and 9 inches (83.8 cm) below the waterline. See figure 1.

**5.3.2** As shown in figure 2, at the depths of (a) and (b), the walls are permitted to join the floor.

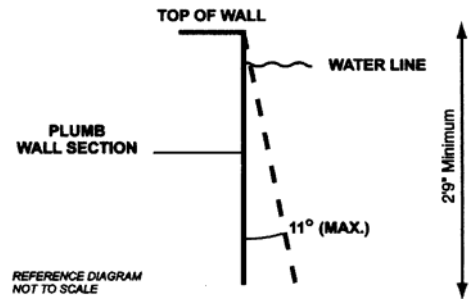
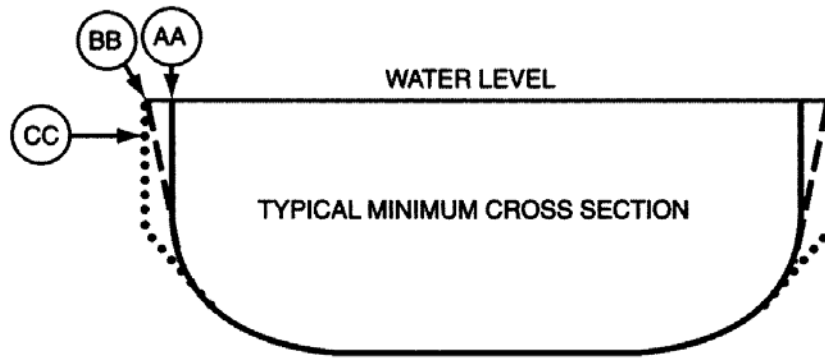
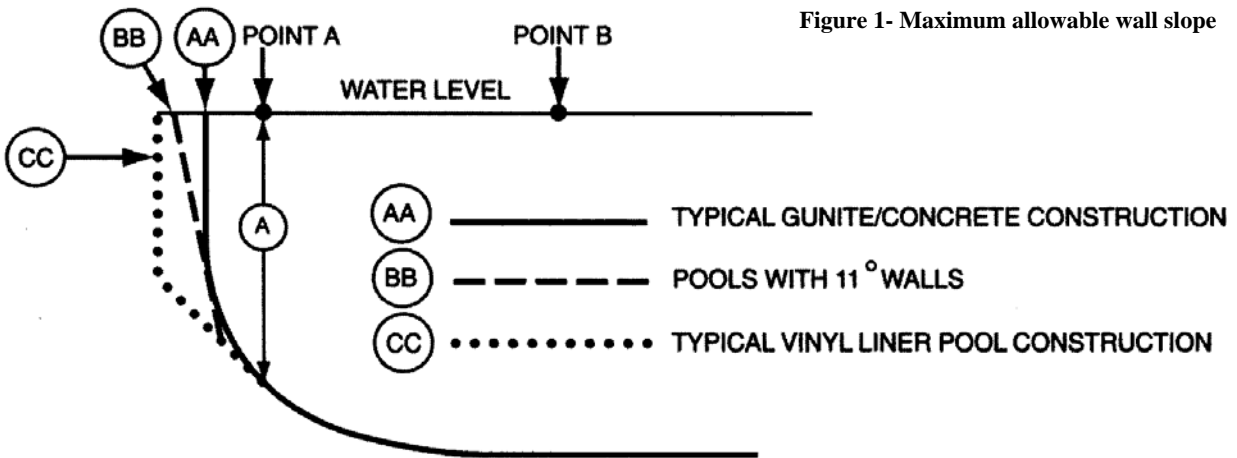

Figure 1- Maximum allowable wall slope



REFERENCE DIAGRAM  
NOT TO SCALE

Figure 2- Typical pool design configurations

5.3.3 The walls of Type I pool, when defining the minimum diving water envelope, shall be plumb or outside of Type 1 water geometry. (See figure3, table 1.)

5.4 Maximum allowable wall slope

5.4.1 Maximum allowable wall slope shall not slope greater than 11° from plumb.

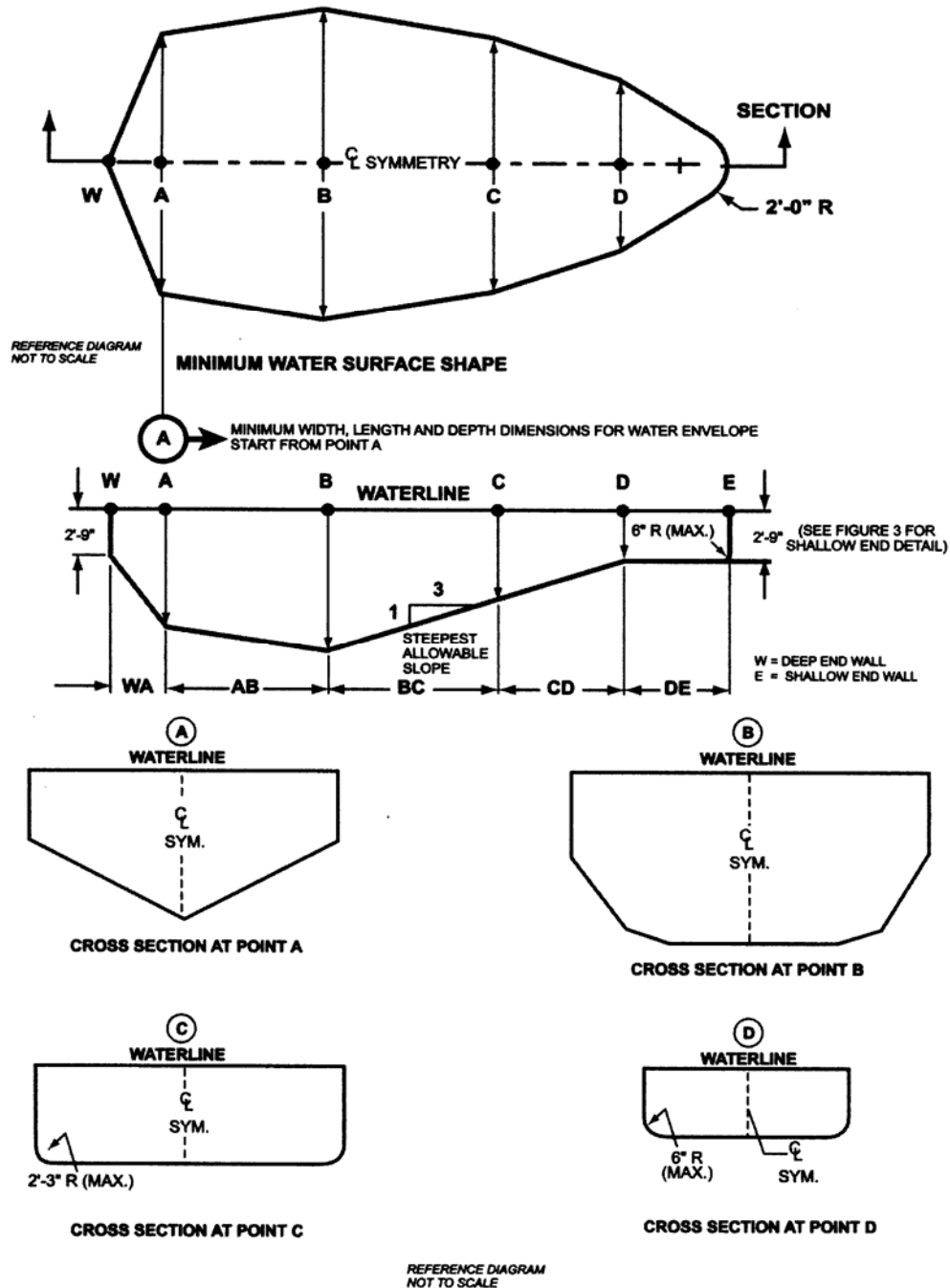

Figure 3- Minimum water envelope

**Table 1- Minimum water envelope**

| Pool type | Minimum depths at point                     |       |       |       | Minimum widths at point |        |        |       | Minimum lengths between points |       |        |        |       |        |
|-----------|---|-------|-------|-------|-------------------------|--------|--------|-------|--------------------------------|-------|--------|--------|-------|--------|
|           | A   | B     | C     | D     | A                       | B      | C      | D     | WA                             | AB    | BC     | CD*    | DE    | WE     |
| O         | Manufactured diving equipment is prohibited |       |       |       |                         |        |        |       |                                |       |        |        |       |        |
| I         | 6'-0"                                       | 7'-6" | 5'-0" | 2'-9" | 10'-0"                  | 12'-0" | 10'-0" | 8'-0" | 1'-6"                          | 7'-0" | 7'-6"  | Varies | 6'-0" | 28'-9" |
| II        | 6'-0"                                       | 7'-6" | 5'-0" | 2'-9" | 12'-0"                  | 15'-0" | 12'-0" | 8'-0" | 1'-6"                          | 7'-0" | 7'-6"  | Varies | 6'-0" | 28'-9" |
| III       | 6'-10"                                      | 8'-0" | 5'-0" | 2'-9" | 12'-0"                  | 15'-0" | 12'-0" | 8'-0" | 2'-0"                          | 7'-6" | 9'-0"  | Varies | 6'-0" | 31'-3" |
| IV        | 7'-8"                                       | 8'-6" | 5'-0" | 2'-9" | 15'-0"                  | 18'-0" | 15'-0" | 9'-0" | 2'-6"                          | 8'-0" | 10'-6" | Varies | 6'-0" | 33'-9" |
| V         | 8'-6"                                       | 9'-0" | 5'-0" | 2'-9" | 15'-0"                  | 18'-0" | 15'-0" | 9'-0" | 3'-0"                          | 9'-0" | 12'-0" | Varies | 6'-0" | 36'-9" |

**NOTE:**

1. \*Minimum length between points CD may vary based upon water depth at point D and the slope between points C & D.
2. Figure 3 drawings are not to scale. (For pool types, see Glossary.)

**5.5 Offset ledges**

**5.5.1** Offset ledges shall be a maximum of 8 inches (20.3 cm) wide.

**5.5.1.1** Offset ledges, located less than 42 inches (1067 mm) below waterline shall be proportionately less than 8 inches (20.3 cm) wide and fall within 11° from plumb, measured from the top of the waterline. See figure 4.

**5.6 Floor slopes.** Floor slopes shall be reasonably uniform and comply with 5.6.1 through 5.6.3.

**5.6.1** The slope of the floor from the shallow end wall towards the deep area shall not exceed 1 foot in 7 feet (30 cm: 213 cm) to the point of the first slope change as shown in figure 5.

**5.6.2** Changes in slope between shallow and deep areas shall be at a minimum water depth of 2 feet 9 inches (83.8 cm) and be at least six feet (182.9 cm) from the shallow end, except as specified in 6.3.

**5.6.3** The slope of the floor from the point of the first slope change toward the deep end shall not exceed 1 foot in 3 feet (30 cm: 91 cm).

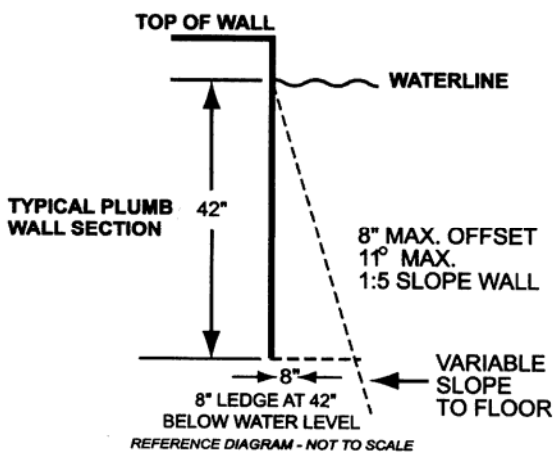

**Figure 4- Offset ledges**

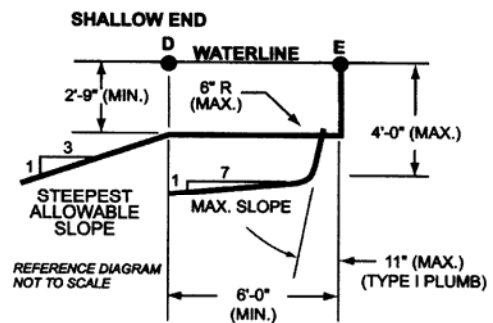

**Figure 5- Shallow end depths**



**5.7 Shallow end water depths.** Water depth in the shallow area shall be a minimum of 2 feet 9 inches (83.8 cm) except for those locations specified in 6.3 "Shallow End Detail for Beach and Sloping Entries." The water depth at the shallowest point shall not exceed four feet (121.9 cm) as shown in figure 5.

**5.8 Manufactured diving equipment for in-ground swimming pools (diving board/stand combination or manufactured platform)**

NOTE – For consumer safety information, warnings and education programs, See appendices D, E, and F.

**5.8.1** When manufactured diving equipment is installed, it shall conform to the specifications set forth in 5.8 through 5.9 and shall be located in the deep area of the pool so as to provide the minimum, dimensions as shown in 5.9.

**5.8.1.1** Manufactured diving equipment shall not be installed on Type 0 pools.

**5.8.2 Diving equipment.** Diving equipment shall be designed for swimming pool use and shall be installed in accordance with the manufacturer's specifications.

**5.8.2.1** Diving equipment installation and use instructions shall be provided by the diving equipment manufacturer and shall specify the minimum water dimensions required for each diving board and diving stand combination. They may refer to the water envelopes type of their choice by dimensionally relating their products to Point A on the water envelopes as shown in figure 3 and table 1, 5.9.1 through 5.9.3.

**5.8.2.2** Diving equipment shall be permanently labeled and affixed to the diving equipment or jump boards and shall include but not be limited to:

- manufacturer's name and address;
- date of manufacture;
- minimum water envelope required for each diving board and diving stand combination; and
- maximum weight limitations of the user as specified by the board manufacturer.

**5.8.2.3** Diving equipment shall have slip-resisting tread surfaces.

**5.9** Fig.3 contains suggested drawings and diagrams for minimum water envelope for swimming

pools designated type I - V. Individual pool types are shown in figure 3 and table 1.

**5.9.1 Location of point A.** Point A shall be defined as a point located on the minimum water envelopes.

**5.9.1.1 Point A.** Point A is a construction location nearest the deep end wall where the minimum water depth is satisfied.

**5.9.1.2** Point A as shown in figure 3 and table 1 shall be the reference point of origin for all dimensions defining the minimum water envelope.

**5.9.2** Type 0 pool (where diving is prohibited) shall not be limited in width, length, or water depth except as specifically provided for in this standard.

**5.9.3 Location of equipment and pool features in the minimum water envelope.** If the pool is designed for use with diving equipment, steps, pool stairs, ladders, underwater benches, special features and other accessory items shall be located outside the minimum water envelope. (See figure 6)

**5.9.4 Typical pool design configurations.** Vinyl liner, shotcrete, fiberglass and concrete constructions shall conform to, but are not limited to, the typical pool configurations shown in figure 2.

**5.10 Stationary diving platform(s) and diving rock(s).** Stationary diving platform(s) and diving rock(s) built on site shall be allowed to be flush with the wall and located in the diving area of the pool. Point A shall be in front of the wall at the platform or diving rock centerline.

NOTE — For consumer safety information, warnings and education programs, See appendices D, E, and F.

**5.10.1** The maximum height of the stationary diving platform or diving rock above the waterline shall be as follows:

- Pool Type I 42 inches (106.7 cm);
- Pool Type II 42 inches (106.7 cm);
- Pool Type III 50 inches (127.0 cm);
- Pool Type IV 60 inches (152.4 cm); or
- Pool Type V 69 inches (175.3 cm)

**5.10.2** Stationary diving platform(s) and diving rock(s) shall not be permitted on Pool Type 0.

**5.10.3** The diving equipment manufacturer shall specify minimum headroom above water.

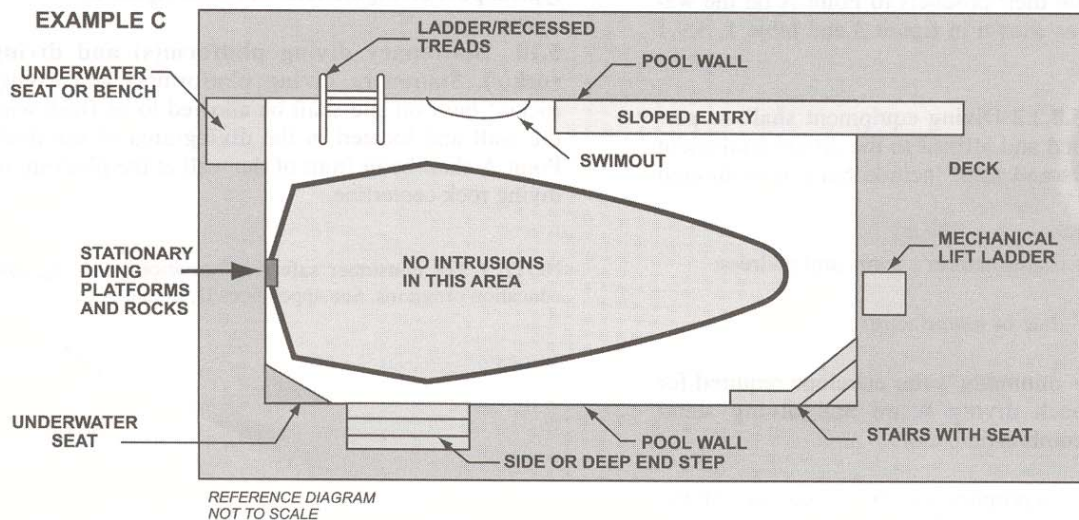
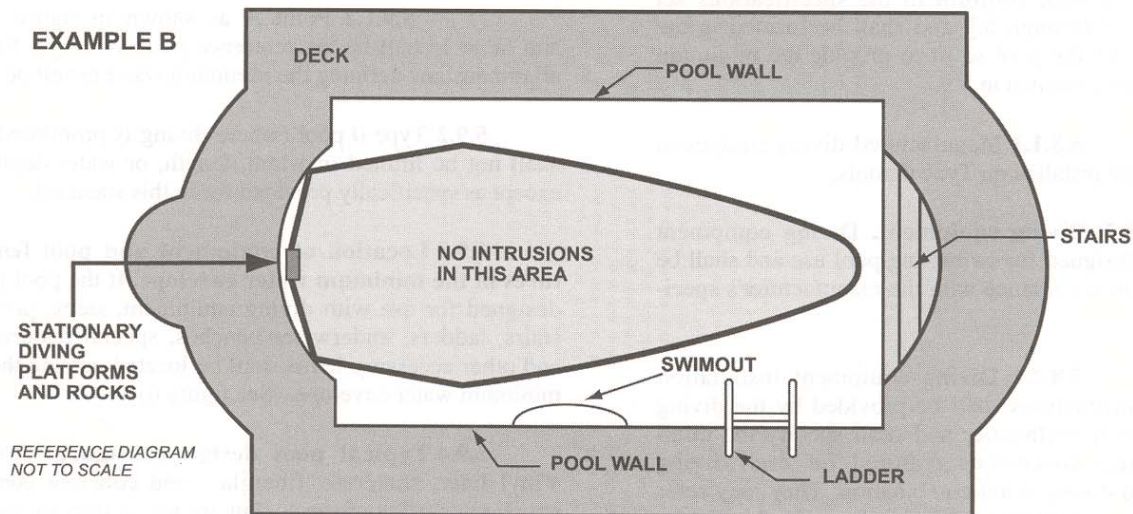
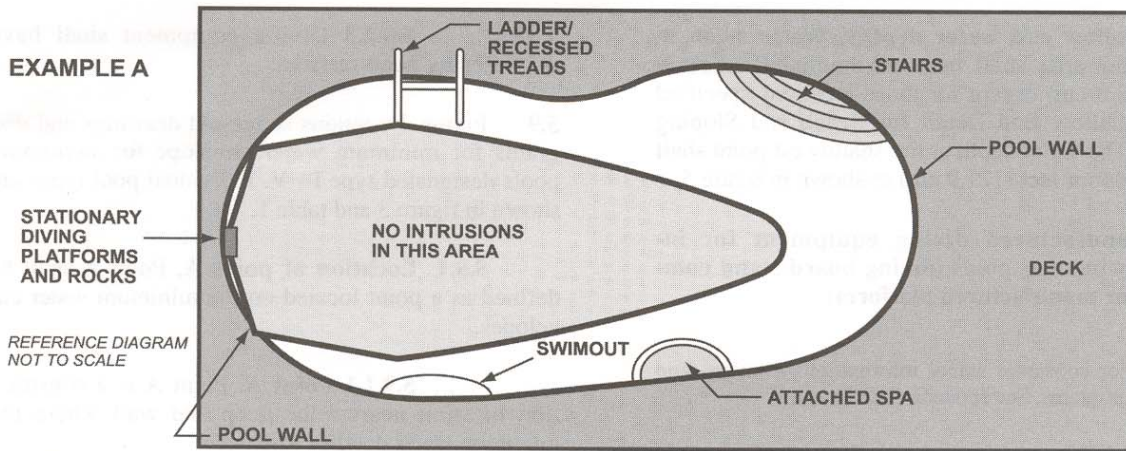

**Figure 6- Top view examples of accessory equipment and pool features prohibited in the water envelope**  
 For a copy of the complete ANSI/NSPI-5 2003 American National Standard for Residential Inground Swimming Pools contact:

National Spa and Pool Institute  
 2111 Eisenhower Avenue  
 Alexandria, VA 22314  
 Phone: (703) 838-0083  
 Fax: (703) 549-0493  
[www.nspi.org](http://www.nspi.org)

**Selected Sections From  
ANSI/NSPI-1 2003  
American National Standard for Public Swimming Pools**

**Standard for  
Public Swimming Pools**

**1 Scope**

**1.1 Public swimming pools.** This standard covers public swimming pools to be used for bathing and operated by an owner, licensee, or concessionaire, regardless of whether a fee is charged for use.

**1.1.1 Public swimming pools covered by this standard.** Public swimming pools covered by this standard include Class A pools (pools used for competitive aquatic sports), Class B and Class C pools, (pools intended for public or semi-public recreational swimming), and Class F pools (for wading). (See article 3 for definitions.)

**1.2 Variation in design.** This standard provides specifications for the design, equipment, operation, warning signs, installation, sanitation, new construction, and renovation of public swimming pools. This standard permits variations in equipment, materials, and design to accommodate special needs and considerations and advances in technology and to provide the required quality, strength, durability, and safety for the intended use.

**1.3 Renovation.** (See appendix H, Glossary.) Renovation does not include ordinary maintenance. Only those items that are renovated shall adhere to this standard.

**2 Normative references**

The following standards contain provisions that, through reference in this text, constitute provisions of, this American National Standard. At the time of publication, the editions indicated were valid. All standards are subject to revision, and parties to agreements based on this American National Standard are encouraged to investigate the possibility of applying the most recent editions of the standards indicated below.

ANSI/ASME A112.19.8M-1987 (1996), *Suction fittings for swimming and wading pools, spas, hot tubs, and whirlpool bathtub appliances*<sup>1</sup>

ANSI/ICC A 117.1 (2003), *Standard on accessible and useable buildings and facilities*<sup>2</sup>

ANSI/NEMA-MG1-1998, *Motors and generators*<sup>3</sup>

ANSI/NSF 14 (2003), *Plastics piping system components and related materials*<sup>4</sup>

ANSI/NSF 50 (2001), *Circulation system components and related materials for swimming pools, spas/hot tubs*<sup>5</sup>

ANSI Z21.56-2001/CSA 4.7-2001, *Gas fired pool heaters*<sup>6</sup>

ACI 302.1R-96 (1996), *Guide for concrete floor and slab construction*<sup>7</sup>

Americans with Disabilities Act (ADA) *Accessibility guidelines for buildings and facilities; recreation facilities*<sup>8</sup>

ASME A112.1.2 (2002), *Air gaps in plumbing systems*<sup>9</sup>

ASTM 1346-91 (2003), *Standard performance specification for safety covers and labeling require-*

---

<sup>1</sup>American National Standards Institute (ANSI), 25 West 43rd Street, New York, NY 10036, NY (212) 642-4900, [www.ansi.org](http://www.ansi.org)

<sup>2</sup>ANSI, previously listed

<sup>3</sup>National Electrical Manufacturers Association (NEMA), 1300 N. 11th Street, Suite 1847, Rosslyn, VA 22209 (703) 841-3200, [www.nema.org](http://www.nema.org)

<sup>4</sup>NSF International, 789 N. Dixboro Rd., Ann Arbor, MI 48113 (734) 769-8010, [www.nsf.org](http://www.nsf.org)

<sup>5</sup>NSF, previously listed

<sup>6</sup>ANSI, previously listed

<sup>7</sup>American Concrete Institute, 38800 Country Club Drive, Farmington Hills, MI 48331, (248) 848-3800, [www.aci-int.org](http://www.aci-int.org)

<sup>8</sup>U.S. Architectural and Transportation Barriers Compliance Board, 1331 F Street, NW, Suite 1000, Washington, DC 20004, (202) 272-0080, [www.access-board.gov](http://www.access-board.gov)

<sup>9</sup>American Society of Mechanical Engineers (ASME), 3 Park Avenue, 20th Floor, New York, NY 10016, (212) 591-8562, [www.asme.org](http://www.asme.org)

ments for all covers for swimming pools, spas and hot tubs<sup>10</sup>

ASTM F2208-02, *Standard specification for pool alarms*<sup>11</sup>

ANSI/NFPA 54-2002, *National fuel gas code*<sup>12</sup>

ANSI/NFPA 70-2002, *National electric code*<sup>13</sup>

UL 1995 (1999), *Standard for heating and cooling equipment*<sup>14</sup>

UL 1261 (2001), *Standard for electric water heaters for pools and tubs*<sup>15</sup>

### 3 Definitions

Public swimming pools are classified as follows for purposes of reference and application of this standard:

**Class A pools** - Class A pools are pools intended for use for accredited competitive aquatic events such as Federation Internationale de Natation Amateur (FINA), U.S.A. Swimming, U.S. Diving, National Collegiate Athletic Association (NCAA), National Federation of State High Schools Associations (NFSA), etc. The pool may also be used for recreation. Class A pools are covered unless otherwise noted in the body of the standard.

**Class B pools** - Class B pools are pools intended for public recreational swimming not otherwise classified. Class B pools are covered within the scope of this standard.

**Class C pools** - Class C pools are pools intended for use for apartments, condominiums, property owners associations, multi-family owned pools, etc. and are

covered within the scope of this standard. Pools operated solely for and in conjunction with lodgings such as hotels and motels are also covered within the scope of this standard.

**Class D pools** -Class D pools are not covered within the scope of this standard. Class D pools are operated for special purposes, including but not limited to wave action pools, activity pools, leisure rivers, vortex pools, and sand bottom pools.

**Class E pools** -Class E pools are pools used for physical therapy and are above 86°F (30°C) and are not covered within the scope of this standard.

**Class F pools** -Class F pools are wading pools and are covered within the scope of this standard as set forth in 6.9 and 8.4.2 and as noted in other sections of the standard.

### 4 Code compliance

**4.1 Codes.** Pools covered by this standard shall be constructed and operated to comply with all local, state, and federal codes governing safety and environmental regulations.

### 5 General design

**5.1 Plans and permits.** Prior to construction, rehabilitation, or alteration of a permanently installed public swimming pool, plans and specifications shall be submitted to the authority (state or local) for review, approval, and issuance of a permit to construct or rehabilitate as required by the authority having jurisdiction.

**5.2 Materials.** Swimming pools and all appurtenances thereto shall be constructed of materials that are nontoxic to humans and the environment; that are generally or commonly regarded to be impervious and enduring; that will withstand the design stresses; and that will provide a watertight structure with a smooth and easily cleaned surface without cracks or joints, excluding structural joints, or to which a smooth, easily cleaned surface/finish is applied or attached.

**5.2.1 Selection of materials.** Clean sand or similar material, if used in a beach pool environment, shall be used only over an impervious surface. The sand

---

<sup>10</sup> ASTM International, 100 Barr Harbor Drive, W. Conshohocken, PA 19428, (610) 832-9585, [www.astm.org](http://www.astm.org)

<sup>11</sup> ASTM, previously listed

<sup>12</sup> National Fire Protection Association (NFPA), 1 Batterymarch Park, Quincy, MA 02269 (617) 770-3000, [www.nfpa.org](http://www.nfpa.org)

<sup>13</sup> NFPA, previously listed

<sup>14</sup> Underwriters Laboratories (UL), 333 Pfingsten Road, Northbrook, IL 60062, (847) 272-8800, [www.ul.com](http://www.ul.com)

<sup>15</sup> UL, previously listed

area shall be designed and controlled so that the circulation system, maintenance, safety, sanitation, and operation of the overall pool are not adversely affected.

**5.3 Structural design.** The structural design shall be in accordance with accepted engineering practices.

**5.4 Freeze protection.** In climates subject to freezing temperatures, the pool shell and appurtenances, piping, filter system, pump and motor, and other components shall be designed and constructed to facilitate protection from damage due to freezing.

**5.5 Surface condition.** The surfaces within the pool intended to provide footing for users shall have a slip-resisting surface and shall not cause injury to the feet during normal use.

**5.6 Colors and finishes.** The colors, patterns, or finishes of the pool interior shall not obscure objects or surfaces within the pool.

**5.7 Accessibility for persons with disabilities.** For Americans with Disabilities Act (ADA) requirements for accessibility for persons with disabilities into public swimming pools, see *ADA Accessibility guidelines for buildings and facilities, recreation facilities* (ADAAG).

**6 Dimensional design**

**6.1 Perimeter shape.** This standard is not intended to regulate the perimeter shape of swimming pools.

It is the designer's responsibility to take into account the effect a given shape will have on the safety of the occupants and required circulation to ensure sanitation. All other dimensions, unless otherwise specified, should allow  $\pm 2$  inches (51 mm) tolerance.

**6.1.1** There shall be no protrusions, extensions, means of entanglement, or obstructions in the swimming pool areas that may cause the entrapment or injury of the user.

**6.2 Allowable construction tolerances.** These construction tolerances are not applicable to Class A pools.

**6.2.1** Finished pool dimensions shall be held within the following construction tolerances as shown in table 1.

**6.3 Floor slope.** Floor slopes shall be in compliance with 6.3.1 through 6.3.5, except the requirements by the ADA Accessibility guidelines (ADAAG).

**6.3.1** All pool floors shall be sloped to the drain.

**6.3.2** The slope of the floor in the shallow area shall not exceed 1 foot in 10 feet in Class C pools or 1 foot in 12 feet in Class B pools in any direction to the point of the first slope change, if a slope change exists.

**6.3.3** The point of the first slope change shall be defined as the point at which the floor slope exceeds 1 foot in 10 feet in Class C pools or 1 foot in 12 feet in Class B pools.

**Table 1 – Construction tolerances**

| <b>Design requirements</b>                                       | <b>Construction tolerance allowed</b> |
|--|---------------------------------------|
| Length – overall   | $\pm 3$ in. (76 mm)                   |
| Width – overall  | $\pm 3$ in. (76 mm)                   |
| Depth – deep area, including diving area                         | $\pm 3$ in. (76 mm)                   |
| Depth – shallow area   | $\pm 2$ in. (51 mm)                   |
| Step treads & risers   | $\pm 1/2$ in. (13 mm)                 |
| Waterline – pools with adjustable weir skimmers                  | $\pm 1/4$ in. (6 mm)                  |
| Waterline – pools with nonadjustable skimming systems (gutters)  | $\pm 1/8$ in. (3 mm)                  |
| Wall slopes  | $\pm 3$ degrees                       |
| All dimensions not otherwise specified in this standard          | $\pm 2$ in. (51 mm)                   |
| Competitive pools – Class A pools – All dimensional requirements | As governed by sanctioned authority   |

**6.3.4** The slope of the floor from the point of the first slope change to the deep area shall not exceed 1 foot in 3 feet.

**6.3.5 Walls.** Where walls join the floor the transitional point or profile shall comply with the following:

- Walls may intersect with the floor at an angle or a transition profile.
- At water depths between 3 feet to 5 feet (91 cm to 152 cm) the maximum radius shall be 2 feet 3 inches (69 cm).
- At water depths of 3 feet (91 cm) or less a transitional radius shall not exceed 6 inches (15 cm) and shall be tangent to the wall and may be tangent to or intersecting the floor.
- At water depths greater than 3 feet (91 cm) a transitional radius shall be tangent to the wall at a point no less than 2 feet and 6 inches (76 cm) below the water surface and may progressively increase from 6 inches (5 cm) to a value capable of being tangent to or intersecting the floor.

**6.4** Water depths for swimming areas shall be a minimum depth of 3 feet (91 cm) unless the authority having jurisdiction specifies otherwise.

**6.4.1** Class A pools shall be designed and constructed to provide the dimensions specified by Federation Internationale de Natation Amateur (FINA), U.S.A. Swimming, U.S. Diving, or other appropriate sanctioning body.

**6.5 Diving.** This standard does not cover diving requirements for Class A pools. This standard covers diving requirements for Class B and Class C pools.

**6.5.1** When diving equipment is installed, it shall conform to the specifications set forth in 7.2.1 through 7.2.5.6. Equipment shall be located in the diving area of the pool on the appropriate ANSI/NSPI pool type (or other water envelopes specified by the diving equipment manufacturer) in accordance with the manufacturer's installation instructions and the minimum dimensions as shown in figure 1. Competitive diving equipment shall not be installed on Class B and Class C pools.

**6.6** The manufacturer of the diving equipment shall specify minimum water envelopes for its products. They may refer to the water envelope type of their choice by dimensionally relating their products to Point "A" on that water envelope. Point "A" as shown in figure 1 is designated as the point of origin on the water surface for the water envelope dimension.

**6.6.1** Point A is a point located on the water surface of pool water envelopes.

**6.6.2** Point A is a construction location nearest the deep end wall where the minimum water depth  $D_1$  is satisfied.

**6.6.3** Point A, as shown in figure 1 and table 2, shall be the referenced point of origin for all dimensions defining a minimum water envelope.

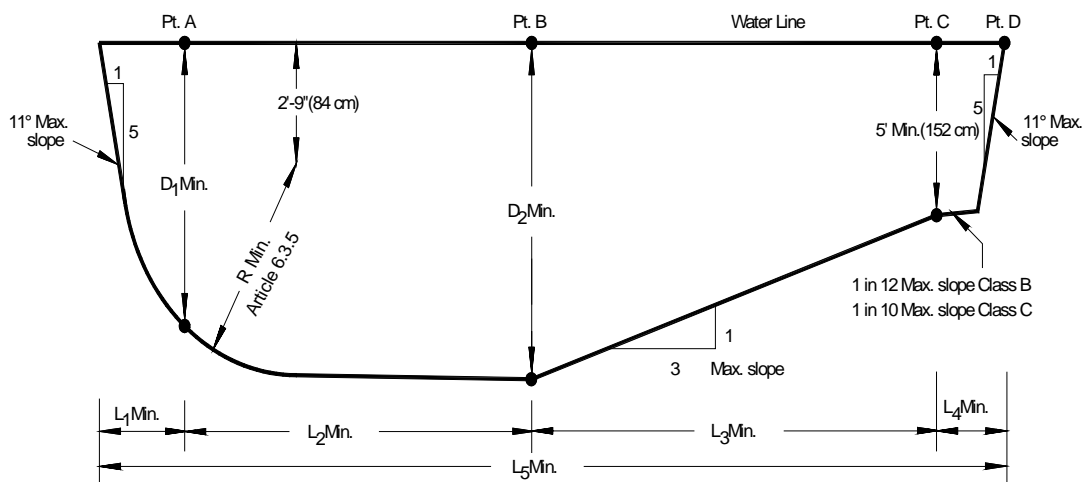

**Figure 1 – Construction dimensions for water envelopes for Class B and Class C pools**

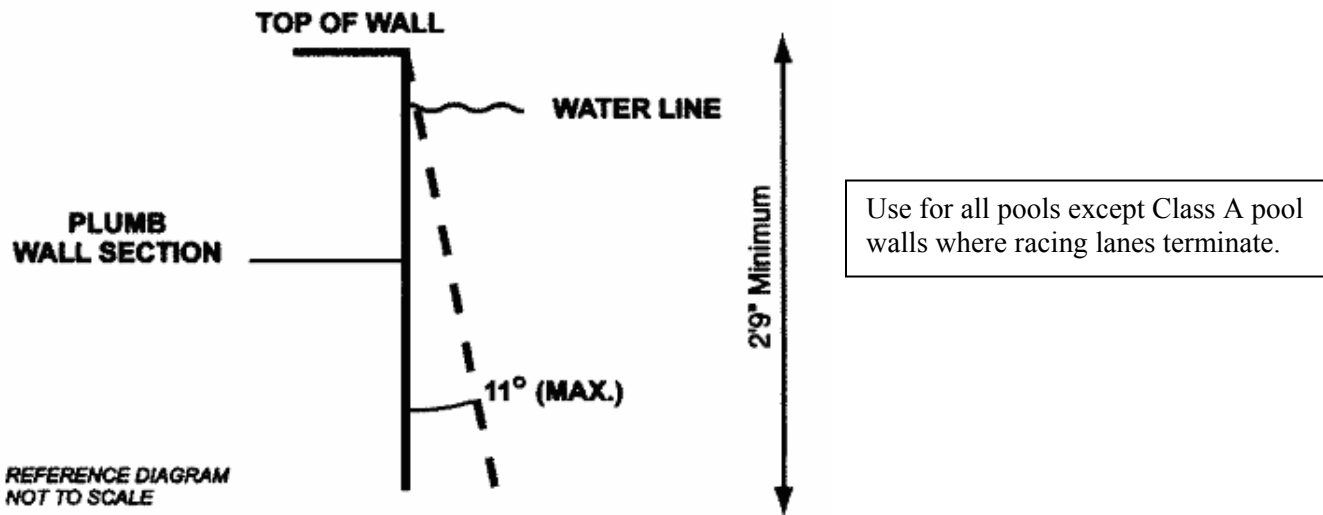

Figure 2 – Maximum allowable wall slope

Table 2 – Minimum water envelopes

| Pool type   | Minimum dimensions |                    |                   |                   |                    |                    |                   |                    | Minimum width of pool at: |                    |                    |
|-------------|--------------------|--------------------|-------------------|-------------------|--------------------|--------------------|-------------------|--------------------|---------------------------|--------------------|--------------------|
|             | D <sub>1</sub>     | D <sub>2</sub>     | R                 | L <sub>1</sub>    | L <sub>2</sub>     | L <sub>3</sub>     | L <sub>4</sub>    | L <sub>5</sub>     | Pt. A                     | Pt. B              | Pt. C              |
| <b>VI</b>   | 7'-0"<br>(213 cm)  | 8'-6"<br>(259 cm)  | 5'-6"<br>(168 cm) | 2'-6"<br>(76 cm)  | 8'-0"<br>(244 cm)  | 10'-6"<br>(320 cm) | 7'-0"<br>(213 cm) | 28'-0"<br>(853 cm) | 16'-0"<br>(488 cm)        | 18'-0"<br>(549 cm) | 18'-0"<br>(549 cm) |
| <b>VII</b>  | 7'-6"<br>(229 cm)  | 9'-0"<br>(274 cm)  | 6'-0"<br>(183 cm) | 3'-0"<br>(91 cm)  | 9'-0"<br>(274 cm)  | 12'-0"<br>(366 cm) | 4'-0"<br>(122 cm) | 28'-0"<br>(853 cm) | 18'-0"<br>(549 cm)        | 20'-0"<br>(610 cm) | 20'-0"<br>(610 cm) |
| <b>VIII</b> | 8'-6"<br>(259 cm)  | 10'-0"<br>(305 cm) | 7'-0"<br>(213 cm) | 4'-0"<br>(122 cm) | 10'-0"<br>(305 cm) | 15'-0"<br>(457 cm) | 2'-0"<br>(61 cm)  | 31'-0"<br>(945 cm) | 20'-0"<br>(610 cm)        | 22'-0"<br>(671 cm) | 22'-0"<br>(671 cm) |
| <b>IX</b>   | 11'-0"<br>(335 cm) | 12'-0"<br>(366 cm) | 8'-6"<br>(259 cm) | 6'-0"<br>(183 cm) | 10'-6"<br>(320 cm) | 21'-0"<br>(640 cm) | 0<br>(0 cm)       | 37'-6"<br>(11.4 m) | 22'-0"<br>(671 cm)        | 24'-0"<br>(732 cm) | 24'-0"<br>(732 cm) |

**Table 3 – Maximum user load**

| <b>Pool/Deck area</b>                                     | <b>Shallow instructional or wading areas</b>       | <b>Deep area (not including the diving area)</b>   | <b>Diving area (per each diving board)</b>        |
|---|--|--|---|
| Pools with minimum deck area (See 7.1.6 through 7.1.6.1.) | 15 sq. ft. per user (1.35 m <sup>2</sup> per user) | 20 sq. ft. per user (1.8 m <sup>2</sup> per user)  | 300 sq. ft. per user (27 m <sup>2</sup> per user) |
| Pools with deck area at least equal to water surface are  | 12 sq. ft. per user (1.08 m <sup>2</sup> per user) | 15 sq. ft. per user (1.35 m <sup>2</sup> per user) | 300 sq. ft. per user (27 m <sup>2</sup> per user) |
| Pools with deck area at least twice the water surface are | 8 sq. ft. per user (0.72 m <sup>2</sup> per user)  | 10 sq. ft. per user (0.9 m <sup>2</sup> per user)  | 300 sq. ft. per user (27 m <sup>2</sup> per user) |

**6.7 Rest ledges.** Rest Ledges along the pool walls are permitted. They must be not less than 4 feet (122cm) below the water surface. If a ledge is provided it shall be at least 4 inches (10 cm) wide and not more than 8 inches (20 cm) wide.

**6.8 Maximum user load.** The maximum user load of Class B or Class C pools shall be in accordance with table 3.

**6.9 Wading pools.** A wading pool shall be a separate pool with an independent circulation system and physically separated from the main pool as described in 6.9.1 through 6.9.4.

**6.9.1** Areas where the water depth at the edge of the pool exceeds 9 inches (23 cm) shall be considered non-entry areas and must be protected by natural or artificial barriers.

**6.9.2** Floors of wading pools shall be uniform and sloped to drain with a minimum slope of 1 foot in 12 feet (30 cm in 360 cm).

**6.9.3** The maximum water depth shall be 18 inches (46 cm).

**6.9.4** The Maximum distance from the top of the deck to the water line shall not exceed 6 inches (15 cm).

**7 Decks and deck equipment.**

**7.1** Decks shall comply with 7.1.1 through 7.1.17 as applicable.

**7.1.1** Deck(s) shall be designed and installed in accordance with the engineering methods required by the authority having jurisdiction.

**7.1.1.1** In the absence of specific local requirements, a concrete deck shall be designed and constructed in accordance with the recommended practices of the most recent edition of American Concrete Institute (ACI) Standard 302.1R-96, *Guide for concrete floor and slab construction*, or in accordance with the requirements of the local authority, the authority having jurisdiction, or both. The deck shall be designed and constructed to meet the applicable requirements of the Americans with Disabilities Act.

**7.1.2** Decks, ramps, coping, and similar step surfaces shall be slip resisting and cleanable.

**7.1.3** Special features in or on deck(s) such as markers, brand insignias, or similar materials shall be slip resisting.

**7.1.4** Step risers for the deck shall be uniform and have a minimum height of 3-3/4 inches (9.5 cm) and a maximum height of 7-1/2 inches (19 cm). A handrail shall be provided for stairs having three or more risers. The minimum tread distance from front to back shall be 11 inches (28 cm).

**7.1.5** The deck or unobstructed access shall be provided at a minimum of 65% of the pool perimeter to meet the requirement of the 10/20 rule. (See appendix H, Glossary.)

**7.1.5.1** A minimum 4 feet (122 cm) deck width shall be provided on the sides and rear of any diving equipment. A deck clearance of 3 feet (91 cm) shall be provided around all other deck equipment.

**7.1.6** The minimum slope of the deck(s) shall be 1/8 inch per 1 foot (3.2 mm per 304.8 mm) for textured, hand-finished concrete decks; 1/4 inch per 1 foot (6.4 mm per 304.8 mm) for exposed aggregate



concrete decks; 1/2 inch per 1 foot (12.7 mm per 304.8 mm) for indoor/outdoor carpeting decks; and 3/8 inch per 1 foot (9.5 mm per 304.8 mm) for brick and heavy textures finishes, unless an alternate drainage method is provided that prevents the accumulation of pooling of water. (See table 4.)

**7.1.6.1** Decks shall be sloped so that standing water shall be no deeper than 1/8 inch (3.2 mm), 20 minutes after the cessation of the addition of water to the deck.

NOTE -Two stacked U.S. quarters can be used to measure the depth. Water should not cover the quarters.

**7.1.7** The maximum slope of all decks, other than wood decks, shall be 1/2 inch per foot (12.7 mm per 304.8 mm) except for ramps.

**7.1.7.1** The maximum slope for wood decks shall be 1/8 inch per 1 foot (3.2 mm per 304.8 mm).

**7.1.7.2** Gaps shall be required between deck boards in wood decks and shall be consistent with approved engineering methods with respect to the type of wood used and shall not cause a tripping hazard.

**7.1.8** The maximum open gap between pool decks and adjoining decks or walkways, including joint material, shall be 3/4 inch (19.1 mm). The difference in vertical elevation between the pool deck and the adjoining sidewalk shall be 1/4 inch (6.4 mm) unless it conforms to 7.1.4.

**7.1.9** Construction joints where the pool coping meets the concrete deck(s) shall be watertight.

**7.1.10** Construction joints where the pool coping meets the concrete deck(s) shall be installed to protect the coping and its mortar bed from damage as a result of the anticipated movement of adjoining deck(s).

**7.1.11** Control joints in deck(s) shall be provided to minimize visible cracks outside the control joints due to imposed stresses and/or movement of the slab.

**7.1.12** Areas where decks join existing concrete work shall be protected by an expansion joint to protect the pool from the pressures of relative movements.

**7.1.13** The edges of all decks shall be radiused, tapered, or otherwise designed to eliminate sharp comers.

**7.1.14** Pressure tests. A pressure test shall be maintained throughout the deck pour and in accordance with 8.4.

**7.1.15** Valves installed in or under any deck(s) shall have access provided for operation, service, and maintenance. Access covers shall be provided.

**7.1.16** Hose bib(s), with a cross connection control to prevent backflow, shall be provided for rinsing down the entire deck and shall be in accordance with the authority having jurisdiction.

**7.1.17** Water-powered devices (such as water- powered lifts) shall have a dedicated hose bib (water source).

**7.2 Deck equipment.** Deck equipment including diving facilities and starting blocks shall comply with 7.2.1 through 7.4 as applicable.

**Table 4 – Typical minimum drainage slope**

| Surface                           | Typical minimum drainage slope (inch per foot) |
|-----------------------------------|--|
| Textured, hand-finished concrete  | 1/8 in. (3.2)                                  |
| Exposed aggregate                 | 1/4 in. (6.4 mm)                               |
| Carpet                            | 1/2 in. (12.7 mm)                              |
| Brick and heavy textures finished | 3/8 in. (9.5 mm)                               |

**7.2.1** A minimum 4 feet (122 cm) deck width shall be provided on the sides and rear of any diving equipment.

**7.2.2 Starting blocks.** Starting blocks are intended for competitive swimming and shall conform to Federation Internationale de Natation Amateur (FINA), U.S.A. Swimming, National Collegiate Athletic Association (NCAA), or National Federation of State High Schools Associations (NFSHSA).

**7.2.3** There shall be a completely unobstructed distance of 14 feet (427 cm) above the tip of the diving board or as specified by the diving equipment manufacturer or the authority having jurisdiction.

**7.2.4** Public pools with diving equipment of 1 meter (39 inches) or greater in height, or pools designed for springboard or platform diving, shall comply with the dimensional design requirements of Federation Internationale de Natation Amateur (FINA), U.S. Diving, National Federation of State High Schools Association (NFSHSA) or the appropriate sanctioning body.

**7.2.5 Diving equipment.** Diving equipment shall be installed in accordance with the manufacturer's specifications.

**7.2.5.1** The diving equipment manufacturer shall affix a label to the diving equipment.

**7.2.5.2** A label shall be permanently affixed to the diving equipment or jump board and shall include but not be limited to the following:

- The minimum water envelope required for each diving board and diving stand combination,
- Manufacturer's name and address,
- Manufacturer's identification and date of manufacture, and
- The maximum weight of the user, visibly located on the diving board.

**7.2.5.3** The diving equipment manufacturer shall provide diving equipment use instructions.

**7.2.5.4** Diving equipment shall have slip-resisting tread surfaces.

**7.2.5.5 Supports for diving equipment.** Supports, platforms, stairs, and ladders for diving equipment shall be designed to carry the anticipated loads. Stairs and ladders shall be of corrosion-resisting material and shall be easily cleanable and with slip-resisting tread. All diving stands higher than 21 inches (53 cm) measured from the deck to the top butt end of the board shall be provided with stairs and/or a ladder. Step treads shall be self-draining.

**7.2.5.6** Diving equipment 1 meter high (39 inches) or greater shall be provided with a top guard rail, which shall be at least 30 inches (76 cm) above the diving board and extend to the edge of the pool wall and to the deck surface.

**7.3 Swimming pool slides.** Swimming pool slides, when installed, shall comply with the requirements of the U.S. Consumer Product Safety Commission (CPSC) as published in the *Code of Federal Regulations*, 16 CFR, Part 1207. The manufacturer shall provide installation and use instructions with each slide. Each slide shall be installed in accordance with the manufacturer's instructions.

**7.4 Play/water activity equipment.** When installed, play/water activity equipment shall be installed in accordance with manufacturer's instructions.

**For a copy of the complete ANSI/NSPI-1 2003 American National Standard for Commercial Inground Swimming Pools contact:**

**National Spa and Pool Institute**  
2111 Eisenhower Avenue  
Alexandria, VA 22314  
Phone: (703) 838-0083  
Fax: (703) 549-0493  
[www.nspi.org](http://www.nspi.org)