

OWNER'S GUIDE

HAYWARD[®]

PRO[™] SERIES PLUS

HIGH-RATE SAND FILTERS

Models S311SX, S311SXV, S360SX

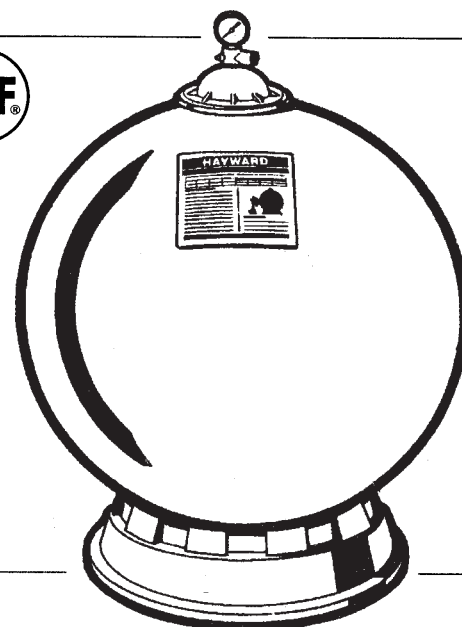

Your Hayward Pro Series high-rate sand filter is a high performance, totally corrosion-proof filter that blends superior flow characteristics and features with ease of operation. It represents the very latest in high-rate sand filter technology. It is virtually foolproof in design and operation and when installed, operated and maintained according to instructions, your filter will produce clear, sparkling water with only the least attention and care.

HOW IT WORKS

Your filter uses special filter sand to remove dirt particles from the water. Filter sand is loaded into the filter tank and functions as the permanent dirt removing media. The pool water, which contains suspended dirt particles, is pumped through your piping system and is automatically directed by the patented filter control valve to the top of the filter tank. As the pool water is pumped through the filter sand, dirt particles are trapped by the sand bed, and filtered out. The cleaned pool water is returned from the bottom of the filter tank, through the control valve and back to the pool through the piping system. This entire sequence is continuous and automatic and provides for total recirculation of pool water through your filter and piping system.

After a period of time, the accumulated dirt in the filter causes a resistance to flow, and the flow diminishes. This means it is time to clean (backwash) your filter. With the control valve in the backwash position, the water flow is automatically reversed through the filter so that it is directed to the bottom of the tank, up through the sand, flushing the previously trapped dirt and debris out the waste line. Once the filter is backwashed (cleaned) of dirt, the control valve is manually resequenced to Rinse (Vari-Flo Control Valve only), and then Filter, to resume normal filtering.

INSTALLATION

Only simple tools (screwdriver and wrenches), plus pipe sealant for plastic adapters, are required to install and/or service the filter.

1. The filter system should be installed, not more than 6 feet above pool water level, on a level concrete slab, very firm ground, or equivalent, as recommended by your pool dealer. Position the filter so that the piping connections, control valve and winter drain are convenient and accessible for operation, service and winterizing.
2. Assemble filter control valve to filter. Align the two (2) valve pipe connections, with O-rings in place, with the two openings in the side of the filter tank and press in firmly. Secure the assembly to the tank connections with the two bulkhead locknuts.

Do not overtighten.

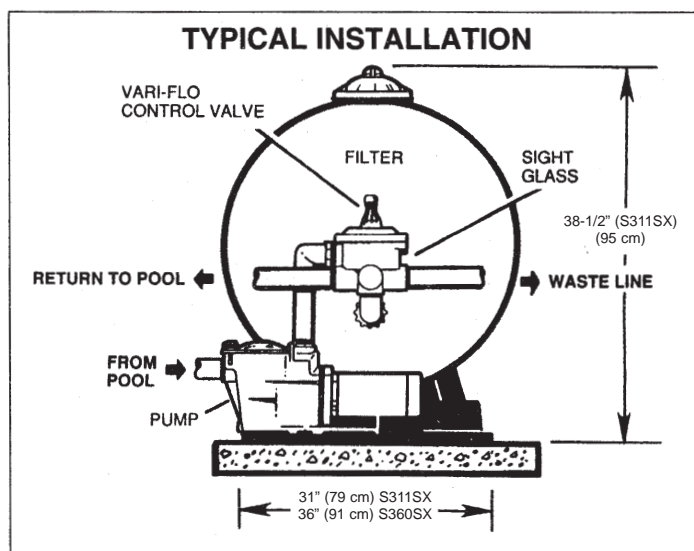

NOTE: If rigid return piping is used, installation of a piping union is recommended for ease of future servicing.

SPECIFICATIONS

MODEL NUMBER	EFFECTIVE FILTRATION AREA		DESIGN FLOW RATE*		PRESSURE LOSS AT DESIGN FLOW RATE		MAXIMUM WORKING PRESSURE		REQUIRED CLEARANCE				MEDIA REQUIRED		
	FT ²	M ²	GPM	LPM	PSI	BAR	PSI	BAR	SIDE		ABOVE		TYPE	AMOUNT	
									INCH	MM	INCH	MM	FILTER SAND**	LBS	KGS
S311SX/SXV	4.95	0.46	99	375	4.8	0.34	50	3.45	18	457	18	457	0.45-0.55	350	159
S360SX	6.68	0.62	133	503	8.6	0.6	50	3.45	18	457	18	457	0.45-0.55	700	318

*Based on 20 GPM/ft² (maximum allowable NSF rating).

**Also known as No. 20 or No. 1/2 Silica Sand.

PARTS Models S311SX, S311SXV, S360SX

REF. NO.	PART NO.	DESCRIPTION	NO. REQ'D.
1	SX200G	Manual Air Relief Cap	1
2	SX200Z5	O-Ring, 3/16" O.D.	1
3	SX244KN	Top Closure Dome, Noryl®	1
4	GMX600F	Valve/Tank O-Ring	1
5	SX310N	Flange Clamp (Valve/Tank)	1
6a	SX311AA2	Filter Tank (S311 - 1995 and Prior)	1
6b	SX311AA2FW	Filter Tank (S311 - After 1996)	1
6c	SX360AA2	Filter Tank (S360 - 1999 and Prior)	1
6d	SX360AA2FW	Filter Tank (S360 - After 1999)	1
7a	SX311G	Label Plate with Label (S311)	1
7b	SX360G	Label Plate with Label (S360)	1
8	SX311Z1	Label Plate Screws	2
9	SX244G	Top Diffuser Assembly	1
10a	SX311CD1	Top Elbow Assembly (S311 - 1995 and Prior)	1
10b	SX311CD1FW	Top Elbow Assembly (S311 - After 1996)	1
11a	SX311CD2	Bottom Elbow Assembly (S311 - 1995 and Prior)	1
11b	SX311CD2FW	Bottom Elbow Assembly (S311 - After 1996)	1
12a	SX360CD	Elbow Assembly, Top & Bottom (S360 - 1999 and Prior)	2
12b	SX360CDFW	Elbow Assembly, Top & Bottom (S360 - After 1999)	2
13	SX310HA	Lateral	10
14a	SX311DA	Folding Umbrella Lateral Holder Assembly (S311 - 1997 -) ***	1
14b	SX242MA3	Folding Umbrella Lateral Holder Assembly (S360) - ***	1
15a	CX1100Z4	Plastic Air Tube (S311)	1
15b	SX360Z2	Air Tube (S360)	1
16	SX200Z2	Air Tube Lock Screw	1
17	SX180G	Gasket	1
18	SX180H	Drain Cap	1
19	SX310J	Filter Support Stand	1
20a	SX220Z3	O-Ring (S311 - 1995 and Prior)	2
20b	SX360Z1	O-Ring (S311, S360 - After 1995)	4
21	SX360E	O-Ring Spacer (S311, S360 - After 1995)	2
22a	DEX360F	Bulkhead Fitting (S311 - 1995 and Prior)	2
22b	SX244P	Bulkhead Fitting (S311 - After 1996, S360 - After 1999)	2
22c	SX311F	Bulkhead Fitting (S360 - 1999 and Prior)	2
23a	SP0710X62	Vari-Flo Valve Assembly —1-1/2" FIP (Optional)	1
23b	SP0715X62	Vari-Flo Valve Assembly —2" FIP (Optional)	1
23c	SP0410X602S	Slide Valve Assembly —2" SKT (Included for S311SXV, Optional for S311SX & S360SX)	1
24	SX200Z4	O-Ring	2
25	ECX270861	Pressure Gauge	1
Optional (Supplied with Model S311SXV Slide Valve Unit Only)			
26	ECX270861	Pressure Gauge	1
27	DEX2400S	Relief Valve/Gauge Adapter Assembly	1
----	DEX2400Z3A	O-Ring for Relief Valve Stem (Set of 3)	1
28	SX200Z5	Relief Valve Assembly O-Ring	1

*** See Diagram A

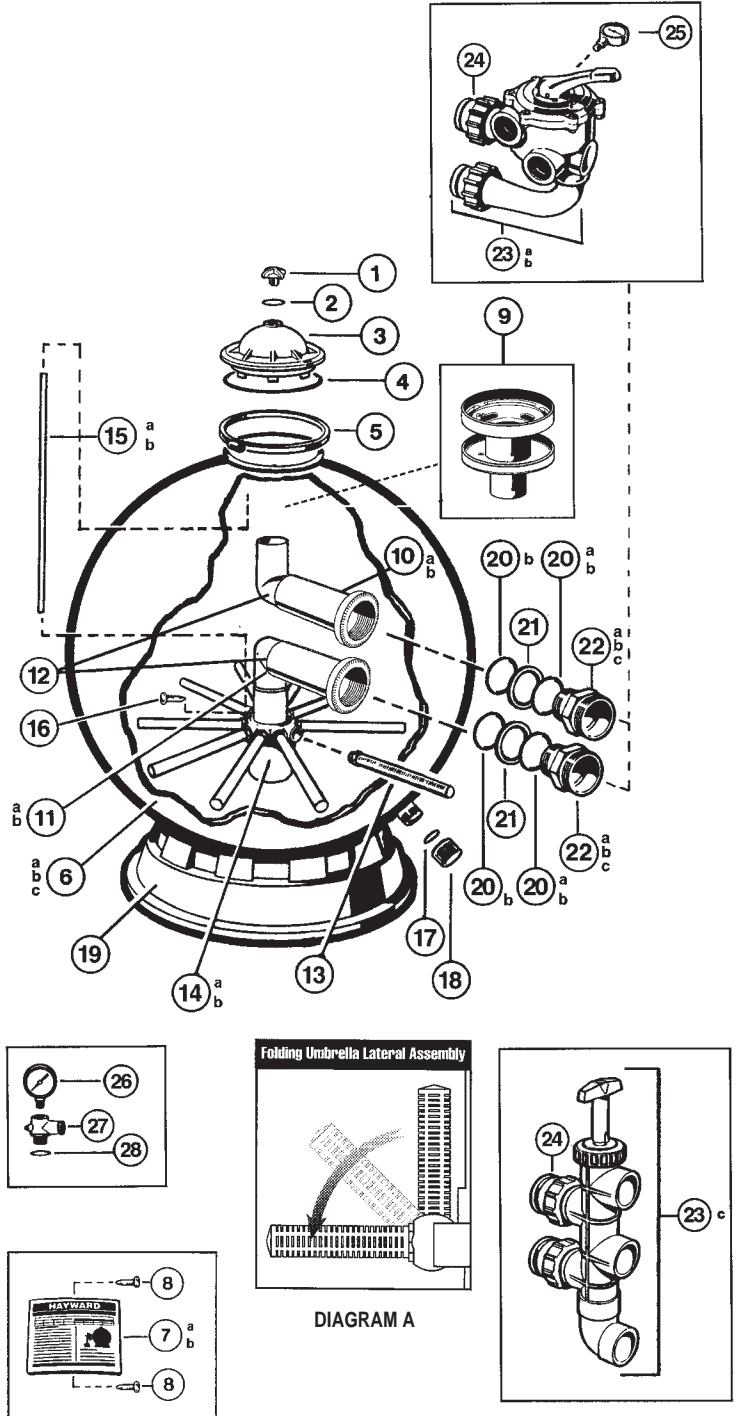

3. Assemble pump and pump mounting base (if supplied) to the filter according to instructions packed with the base.
4. Loading sand media. Filter sand media is loaded through the top opening of the filter.
 - a. Remove the top diffuser from the internal diffuser elbow pipe and place flexible automatic air relief tube to the side, out of the way, inside the tank.
 - b. Cap the internal diffuser elbow pipe with sand shield provided to prevent sand from entering it. **DO NOT MOVE ELBOW PIPE** as this can affect the integrity of the bulkhead seal.
 - c. It is good practice to fill tank approximately 1/2 way with water to provide a cushioning effect when the filter sand is poured in. This helps protect the underdrain laterals from excessive shock. (Be sure the drain cap is securely in place on drain pipe.) **Note: Check to confirm all laterals are in the down position before loading with sand. (See Figure A on Page 2.)**
 - d. Carefully pour in correct amount and grade of filter sand, as specified. Sand surface should be leveled and should come to about the middle of the filter tank. Use no more than the recommended amount of sand.
 - e. Remove sand shield from internal diffuser elbow pipe.
 - f. Replace diffuser on internal diffuser elbow pipe, positioning automatic air relief tube through the hole provided in the diffuser.
 - g. Place stainless steel valve flange clamp around neck of tank. Do not overtighten. Wipe filter flange clean.
 - h. Insert Top Closure Dome (with flange O-ring in place) into the tank neck. Place clamp around dome flange and tank flange and tighten with screwdriver, tapping around clamp with screwdriver handle to help seat flange clamp.
5. Connect pump to control valve opening marked PUMP according to instructions. Make return to pool pipe connection to control valve opening marked RETURN and complete other necessary plumbing connections, suction lines to pump, waste, etc.
6. Make electrical connections to pump per pump instructions.
7. To prevent water leakage, be sure drain cap is securely in place and all pipe connections are tight.

INITIAL START-UP OF FILTER

1. Be sure correct amount of filter sand media is in tank and that all connections have been made and are secure.
2. Depress Vari-Flo control valve handle and rotate to BACKWASH* position. (To prevent damage to control valve seat, always depress handle before turning).
3. Prime and start pump according to pump instructions (be sure all suction and return lines are open), allowing the filter tank to fill with water. **CAUTION: All suction and discharge valves must be open when starting the system. Failure to do so could cause severe personal injury and/or property damage.** Once water flow is steady out the waste line, run the pump for at least 2 minutes. This initial backwashing of the filter is recommended to remove any impurities or fine sand particles in the sand media.
4. Turn pump off and set valve to RINSE position (Vari-Flo

Control Valve only). Start pump and operate until water in sight glass is clear—about 1/2 to 1 minute. Turn pump off, set valve to FILTER position and restart pump. Your filter is now operating in the normal filter mode, filtering particles from the pool water.

5. Adjust pool suction and return valves to achieve desired flow. Check system and filter for water leaks and tighten connections, bolts, nuts, as required.
6. Note the initial pressure gauge reading when the filter is clean. (It will vary from pool to pool depending upon the pump and general piping system). As the filter removes dirt and impurities from the pool water, the accumulation in the filter will cause the pressure to rise and flow to diminish. When the pressure gauge reading is 6-8 PSI (0.41-0.55 BAR) higher than the initial “clean” pressure you noted, it is time to backwash (clean) the filter (see BACKWASH under Filter Control Valve Functions).

NOTE: During initial clean-up of the pool water it may be necessary to backwash frequently due to the unusually heavy initial dirt load in the water.

IMPORTANT: To prevent unnecessary strain on piping system and valving, always shut off pump before switching Filter Control Valve positions.

To prevent damage to the pump and filter and for proper operation of the system, clean pump strainer and skimmer baskets regularly.

FILTER CONTROL VALVE FUNCTIONS

FILTER—Set valve to FILTER for normal filtering. Also use for regular vacuuming.

BACKWASH—For cleaning filter. When filter pressure gauge rises 6-8 PSI (0.41-0.55 BAR) above start-up (clean pressure): Stop the pump, set valve to BACKWASH. Start pump and backwash approximately 2 minutes or less depending on dirt accumulation, until water in sight glass is clear. Proceed to RINSE.

RINSE—After backwashing, with pump off, set valve to RINSE. Start pump and operate for about 1/2 to 1 minute. This ensures that all dirty water from backwashing is rinsed out to the filter to waste, preventing possible return to the pool. Stop pump, set valve to FILTER, and start pump for normal filtering.

WASTE—To bypass filter for draining or lowering water level and for vacuuming heavy debris directly to waste.

RECIRCULATE—Water is recirculated through the pool system, bypassing the filter.

CLOSED—Shuts off flow from pump to filter.

VACUUMING—Vacuuming can be performed directly into the filter. When vacuuming heavy debris loads, set valve to WASTE position to bypass the filter and vacuum directly out to waste.

FILTER CONTROL SLIDE VALVE -Two positions

FILTER and BACKWASH selections are provided for all necessary operational functions.

FILTER—Set Valve to FILTER for normal filtering. Also use for vacuuming (handle in DOWN position).

BACKWASH—For pressure cleaning filter (handle in UP position).

*NOTE: For new concrete or gunite pools, or where there is a large amount of plaster dust or debris—start filter in FILTER position (not BACKWASH) to prevent clogging of underdrain laterals.

WINTERIZING

1. Completely drain tank by unscrewing drain cap at base of filter tank. Leave cap off during winter.
2. Depress control valve handle (if used) and rotate so as to set pointer on valve top between any two positions. This will allow water to drain from the valve. Leave valve in this "inactive" position.

3. Drain and winterize pump according to pump instructions.

SERVICE & REPAIRS

Consult your local authorized *Hayward* dealer or service center. No returns may be made directly to the factory without the expressed written authorization of Hayward Pool Products, Inc.

PLEASE REALIZE . . .

Pure, clear swimming pool water is a combination of two factors—adequate filtration and proper water chemistry balance. One without the other will not give the clean water you desire.

Your filter system is designed for continuous operation. However, this is not necessary for most swimming pools. You can determine your filter operation scheduled based on your pool size and usage. Be sure to operate your

filtration system long enough each day to obtain at least one complete turnover of your pool water.

To properly sanitize your pool, maintain a free chlorine level of 1 to 3 ppm and a pH range of 7.2 to 7.6. Insufficient chlorine or an out of balance pH level will permit algae and bacteria to grow in your pool and make it difficult for your filter to properly clean the pool water.

PROBLEM SOLVING LIST

	LOW WATER FLOW	SHORT FILTER CYCLES	POOL WATER WON'T CLEAR UP
REMEDY	<ol style="list-style-type: none"> 1. Check skimmer and pump strainer baskets for debris. 2. Check for restrictions in intake and discharge lines. 3. Check for air leak in intake line (indicated by bubbles returning to pool). 4. Backwash filter. 	<ol style="list-style-type: none"> 1. Check for algae in pool and superchlorinate as required. 2. Be sure chlorine and pH levels are in proper range (adjust as required). 3. Check surface of filter sand for crusting or caking (remove 1" of sand if necessary). 	<ol style="list-style-type: none"> 1. Check chlorine, pH and total alkalinity levels and adjust as required. 2. Be sure flow rate through filter is sufficient. 3. Operate filter for longer periods. 4. Be sure Vari-Flo valve is set on "Filter" position.

POOL CHEMISTRY GUIDELINES

SUGGESTED POOL CHEMISTRY LEVELS	ACTION REQUIRED TO CORRECT POOL CHEMISTRY	
	TO RAISE	TO LOWER
pH 7.2 to 7.6	Add Soda Ash	Add Muriatic Acid or Sodium Bisulphate
TOTAL ALKALINITY 100 to 130 ppm	Add Sodium Bicarbonate	Add Muriatic Acid
CHLORINE (UNSTABILIZED) 0.3 to 1.0 ppm	Add Chlorine Chemical	No action - chlorine will naturally dissipate
CHLORINE (STABILIZED) 1.0 to 3.0 ppm	Add Chlorine Chemical	No action - chlorine will naturally dissipate
CHLORINE STABILIZER (Cyanuric Acid) 40 to 70 ppm	Add Stabilizer	Dilution - partially drain & refill pool with water that has not been treated with Cyanuric Acid.



HAYWARD POOL PRODUCTS, INC.

Hayward Pool Products, Inc.
900 Fairmount Avenue
Elizabeth, NJ 07207

Hayward Pool Products, Inc.
2875 Pomona Boulevard
Pomona, CA 91768

Hayward Pool Products Canada
2880 Plymouth Drive
Oakville, Ontario L6H 5R4

Hayward Pool Products Europe
ZA dell'Observatoire
2, Avenue des Chaumes
78182 St. Quentin en Yvelines Cedex
France