

MiniMax[®] NT Pool & Spa Heaters

OPERATION & INSTALLATION MANUAL



Pentair
Pool Products[®]

Because *reliability* matters most

U.S. Patent Numbers
6,295,980
5,318,007 - 5,228,618
5,201,307 - 4,595,825

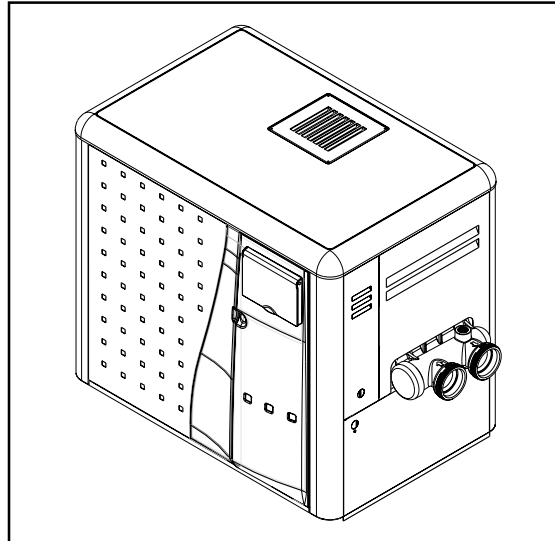

To
Consumer
Retain For
Future
Reference

⚠ WARNING

FOR YOUR SAFETY - READ BEFORE OPERATING

- If you do not follow these instructions exactly, a fire or explosion may result, causing property damage, personal injury or loss of life.
- Improper installation, adjustment, alteration, service or maintenance can cause property damage, personal injury or death. Installation and service must be performed by a qualified installer, service agency or the gas supplier.
- Do not store or use gasoline or other flammable vapors and liquids in the vicinity of this heater or other appliances.

WHAT TO DO IF YOU SMELL GAS

- Do not try to light any appliance.
- Do not touch any electrical switch; do not use any phone in your building.
- Immediately call your gas supplier from a neighbor's phone. Follow the gas supplier's instructions.
- If you cannot reach your gas supplier, call the fire department.

For additional free copies of this manual; call (800) 831-7133.

Pentair Pool Products, Inc.

1620 Hawkins Ave., Sanford, NC 27330 • (919) 774-4151
10951 W. Los Angeles Ave., Moorpark, CA 93021 • (805) 523-2400

Table of Contents

Heater Identification Information	3
Introduction	4
Important Notices	4
Code Requirements	4
Warranty Information	5
Operation	5
Safety Rules	5
HSI (Hot-Surface Ignition) Lighting/Operation	6
Installation Instructions	7
Specifications	7
Installation — Electrical	8
Installation — Wiring Schematic for all Dual Voltage Blowers	9
Installation — Wiring Diagram	10
Installation — Schematic for Remote Control (2 and 3 Wire)	11
Installation — Operating Controls	12 - 13
Installation — Troubleshooting Controls	13 - 14
Installation — Plumbing	15
Installation — Water Connections	16
Installation — Gas Line	17
Installation — Sediment Traps	17
Pipe Sizing Chart/Gas Pressure Requirements	18
Regulated Manifold Pressure Test	18
Venting — Indoor Installations	19 - 22
Venting — Outdoor Installations	23
Basic Operation — General Description	24
Basic Operation — Safety Controls	25 - 26
Maintenance	27
Maintenance Instructions	27
Pressure Relief Valve	27
Maintenance (Water Treatment)	28
Trouble Shooting	29
Troubleshooting (General)	29
Troubleshooting (Service Checks - Ignition Module)	29
MiniMax NT Parts List & Exploded View (Dual Voltage)	30-31
Warranty Information	Back Cover

HEATER IDENTIFICATION INFORMATION

H. I. N. HEATER IDENTIFICATION NUMBER ID DESIGNATOR FOR PENTAIR POOL & SPA HEATERS

HTR 400 NT STD NH ASHI

BLANK = STANDARD MODEL
ASME = ASME CERTIFIED
ASHI = ASME CERTIFIED AND HIGH ALTITUDE RATED
HALT = HIGH ALTITUDE RATED
CAN = CANADIAN UNIT
CANH = CANADIAN HIGH ALTITUDE
WCRD = WITH 6 FT CORD - DSI 100 ONLY

H = HOT SURFACE IGNITION

N = NATURAL GAS
P = PROPANE GAS

STD = NON LOW NOX

NT = MINIMAX NT SERIES

MODEL SIZE = BTU INPUT in 1000 of BTU / HR

Introduction

MiniMax[®] NT Pool and Spa Heaters

Congratulations on your purchase of a MiniMax NT high performance heating system. Proper installation and service of your new heating system and correct chemical maintenance of the water will ensure years of enjoyment. The MiniMax NT is a compact, lightweight, efficient, induced-draft, gas fired high performance pool and spa heater that can be directly connected to schedule 40 PVC pipe. The MiniMax NT also comes equipped with the Pentair multifunction temperature controller which shows, at a glance, the proper functioning of the heater. All HSI (hot-surface ignition) MiniMax NT heaters are designed with a direct ignition device (HSI) which eliminates the need for a standing pilot. The MiniMax NT requires an external power source (120/240 VAC 60 Hz) to operate.

IMPORTANT NOTICES

...For the installer and operator of the MiniMax NT pool and spa heater. The manufacturer's warranty may be void if, for any reason, the heater is improperly installed and/or operated. Be sure to follow the instructions set forth in this manual. If you need any more information, or if you have any questions regarding to this pool heater, please contact Pentair Pool Products, Inc. at (800) 831-7133.

These heaters are designed for the heating of swimming pools and spas, and should never be employed for use as space heating boilers, general purpose water heaters, in non-stationary installations, or for the heating of salt water.

⚠ CAUTION

OPERATING THIS HEATER CONTINUOUSLY AT WATER TEMPERATURE BELOW 68° F. WILL CAUSE HARMFUL CONDENSATION AND WILL DAMAGE THE HEATER AND WILL VOID THE WARRANTY.

Do not use the heater to protect pools or spas from freezing if the final maintenance temperature desired is below 68° F. as this will cause condensation related problems.

CODE REQUIREMENTS

The installation must conform with local codes or, in the absence of local codes, with the *National Fuel Gas Code, ANSI Z223.1/NFPA 54* and/or *CSA B149.1, Natural Gas and Propane Installation Codes*. If an external electrical source is utilized, the heater, when installed, must be electrically grounded and bonded in accordance with local codes or, in the absence of local codes, in the USA, with the *National Electrical Code, ANSI/NFPA 7*; in Canada, with *Canadian Electric Code, CSA C22.1-98*.



This instruction manual provides operating instructions, installation and service information for the MiniMax NT high performance heater. The information in this manual applies to all MiniMax NT models.

It is very important that the owner/installer read and understand the section covering installation instructions, and recognize the local and state codes before installing the MiniMax NT. History and experience has shown that most heater damage is caused by improper installation practices.

WARRANTY INFORMATION

The MiniMax NT pool heater is sold with a limited factory warranty. *Specific details are described on the back cover of this manual and a copy of the warranty and warranty registration card are included with the product.* Return the warranty registration card after filling in the serial number from the rating plate inside the heater.

Pentair Pool Products' high standards of excellence include a policy of continuous product improvement resulting in your state-of-the-art heater. We reserve the right to make improvements which change the specifications of the heater without incurring an obligation to update the current heater equipment.

Operation



SAFETY RULES

1. Spa or hot tub water temperatures should never exceed 104° F. A temperature of 100° F. is considered safe for a healthy adult. Special caution is suggested for young children.
2. Drinking of alcoholic beverages before or during spa or hot tub use can cause drowsiness which could lead to unconsciousness and subsequently result in drowning.
3. Pregnant women beware! Soaking in water above 100° F. can cause fetal damage during the first three months of pregnancy (resulting in the birth of a brain-damaged or deformed child). Pregnant women should stick to the 100° F. maximum rule.
4. Before entering the spa or hot tub, the user should check the water temperature with an accurate thermometer. Spa or hot tub thermostats may err in regulating water temperatures by as much as 4° F.
5. Persons with a medical history of heart disease, circulatory problems, diabetes or blood pressure problems should obtain their physician's advice before using spas or hot tubs.
6. Persons taking medication which induce drowsiness, such as tranquilizers, antihistamines or anticoagulants should not use spas or hot tubs.

⚠ WARNING

Should overheating occur or the gas supply fail to shut off, turn off the manual gas control valve to the heater. Do not use this heater if any part has been under water. Immediately call a qualified service technician to inspect the heater and to replace any part of control system and gas control which has been under water.



MINIMAX NT HSI ELECTRONIC IGNITION LIGHTING/OPERATION**FOR YOUR SAFETY: READ BEFORE LIGHTING****⚠ WARNING**

If you do not follow these instructions exactly, a fire or explosion may result causing property damage, personal injury or loss of life.

Do not attempt to light the heater if you suspect a natural gas leak. Lighting the heater can result in a fire or explosion which can cause personal injury, death, and property damage.

- A. This appliance does not have a pilot. It is equipped with an ignition device which automatically lights the burners. Do not try to light the burners by hand.
- B. **BEFORE OPERATING**, smell all around the appliance area for gas. Be sure to smell next to the floor because some gas is heavier than air and will settle on the floor.
- WHAT TO DO IF YOU SMELL GAS**
- Do not try to light any appliance.
 - Do not touch any electrical switch; do not use any phone in your building.
 - Immediately call your gas supplier from a neighbor's phone. Follow the gas supplier's instructions.
- If you cannot reach your gas supplier, call the Fire Department.
- C. Use only your hand to push in or turn the gas control knob. Never use tools. If the knob will not push in or turn by hand, don't try to repair it, call a qualified service technician. Forced or attempted repair may result in a fire or explosion.
- D. Do not use this appliance if any part has been under water. Immediately call a qualified service technician to inspect the appliance and to replace any part of the control system and any gas control which has been under water.

OPERATING INSTRUCTIONS

1. **STOP!** Read the safety information above.
 2. Turn off electric power to the heater.
 3. Set the thermostat to the lowest setting.
 4. This appliance is equipped with an ignition device which automatically lights the burners. Do not try to light the burners by hand.
 5. Remove the control access door.
 6. Push in gas control knob slightly and turn clockwise  to "OFF".
- NOTE: Knob cannot be turned to "OFF" unless knob is pushed in slightly. Do not force.
7. Wait five (5) minutes to clear out any gas. If you then smell gas, **STOP!** Follow "B" in the safety information above. If you don't smell gas, go to the next step.
 8. Turn gas control knob counterclockwise  to "ON". See Figure 1.
 9. Replace the control access door.
 10. Set the thermostat to the desired setting.
 11. Turn on the electrical power to the appliance.
 12. If the appliance will not operate, follow the instructions "To Turn Off Gas To Appliance" and call your service technician or gas supplier.

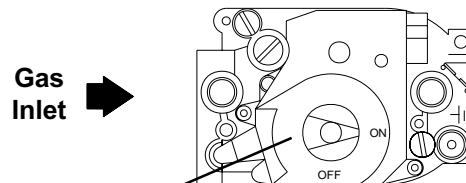



Figure 1. ← Gas control knob shown in "ON" position.

TO TURN OFF GAS TO APPLIANCE

1. Turn off all electric power to the appliance if service is to be performed.
2. Set the thermostat to lowest setting.
3. Remove control access door.
4. Push in gas control knob slightly and turn clockwise  to "OFF". **Do not force.**
5. Replace control access door.

Installation Instructions

SPECIFICATIONS

IMPORTANT NOTICE: These installation instructions are designed for use by qualified personnel only, trained especially for installation of this type of heating equipment and related components. Some states require installation and repair by licensed personnel. If this applies in your state, be sure your contractor bears the appropriate license. See Figure 2 for Outdoor and Figure 3 for Indoor Ventilation.

OUTDOOR VENTILATION

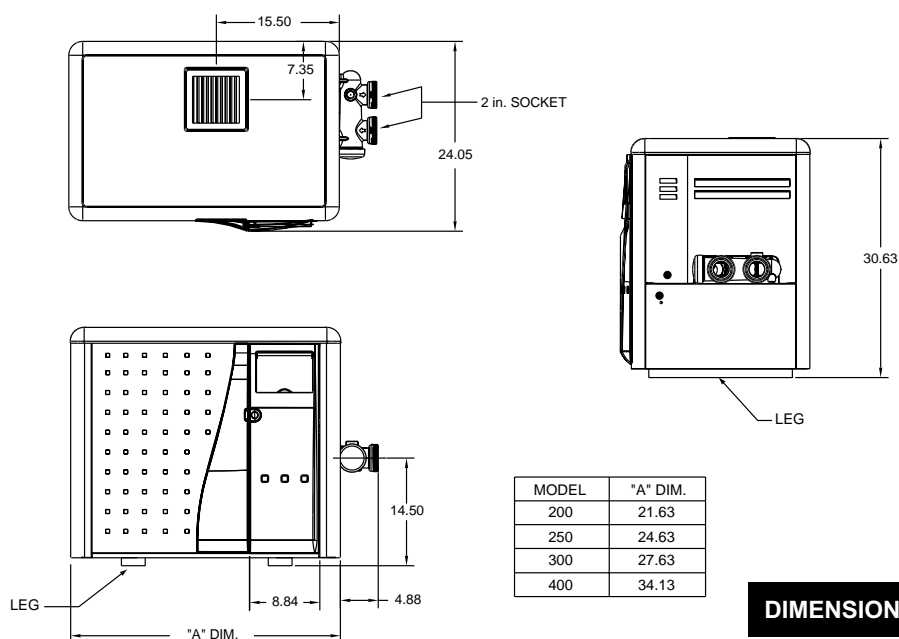

Figure 2.

DIMENSIONS IN INCHES

INDOOR VENTILATION

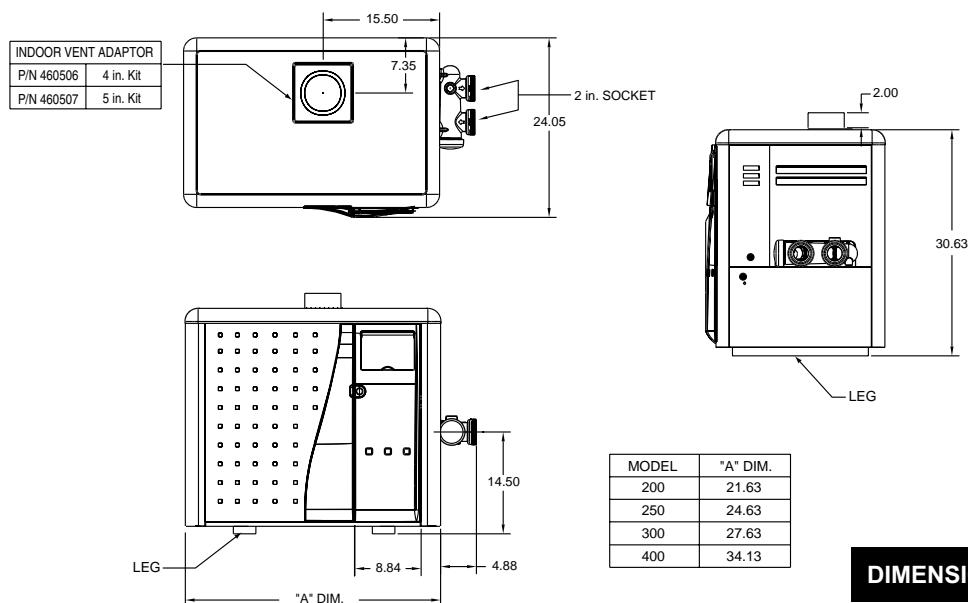

Figure 3.

DIMENSIONS IN INCHES

ELECTRICAL, for MiniMax NT Heaters

Electrical Rating 60 Hz 120 / 240 Volts AC, single phase

NOTE

- The MiniMax NT heater is prewired for 240 volt AC connection using the "RED/BROWN" female connector and the "WHITE" common male connector; see below, Figure 4. If you require the heater to be connected to 120 volts AC, remove the "RED/BROWN" female connector from the "WHITE" common connector; now locate the "BLUE" female connector and plug it into the "WHITE" common connector. When connecting the home wiring to the "Line Terminal Block" inside the junction box, follow the polarity as shown below. Connecting to 120 VAC, make sure that you connect the positive wire to the positive terminal (L), the neutral wire is connected to the neutral terminal (N) and the ground is connected to the ground terminal (GND); see below, Figure 5.
- If any of the original wiring supplied with this heater must be replaced, installer must supply (No. 18 AWG, 600V, 105° C. U.L. approved AWM low energy stranded) copper wire or it's equivalent. Thermal fuse wiring must be replaced with 18 AWG, 600V, 150° C temp. rating. Interconnecting wiring to appliance must conform to the National Electrical Code or supercede local (wiring) codes.

WARNING

The installation must conform with local codes or, in the absence of local codes, with the *National Fuel Gas Code, ANSI Z223.1/NFPA 54* and/or *CSA B149.1, Natural Gas and Propane Installation Codes*. If an external electrical source is utilized, the heater, when installed, must be electrically grounded and bonded in accordance with local codes or, in the absence of local codes, in the USA, with the *National Electrical Code, ANSI/NFPA 7*; in Canada, with *Canadian Electric Code, CSA C22.1-98*.

- Always use crimp type connectors when connecting two wires.

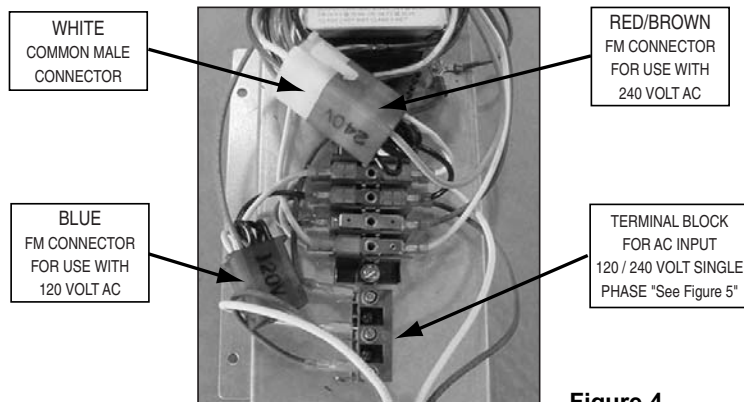

Figure 4.

You might need to open the jacket (upper panel) for servicing the Line Terminal Block as shown in Figures 4 & 5.

LINE TERMINAL BLOCK

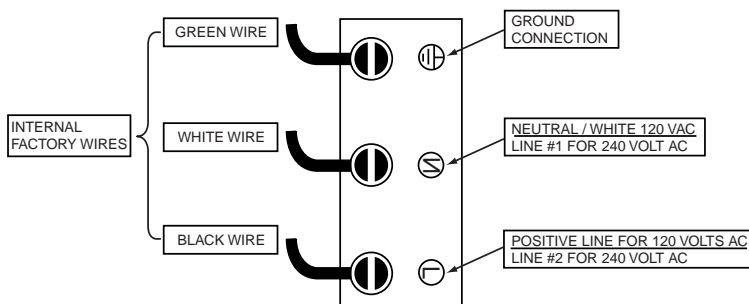
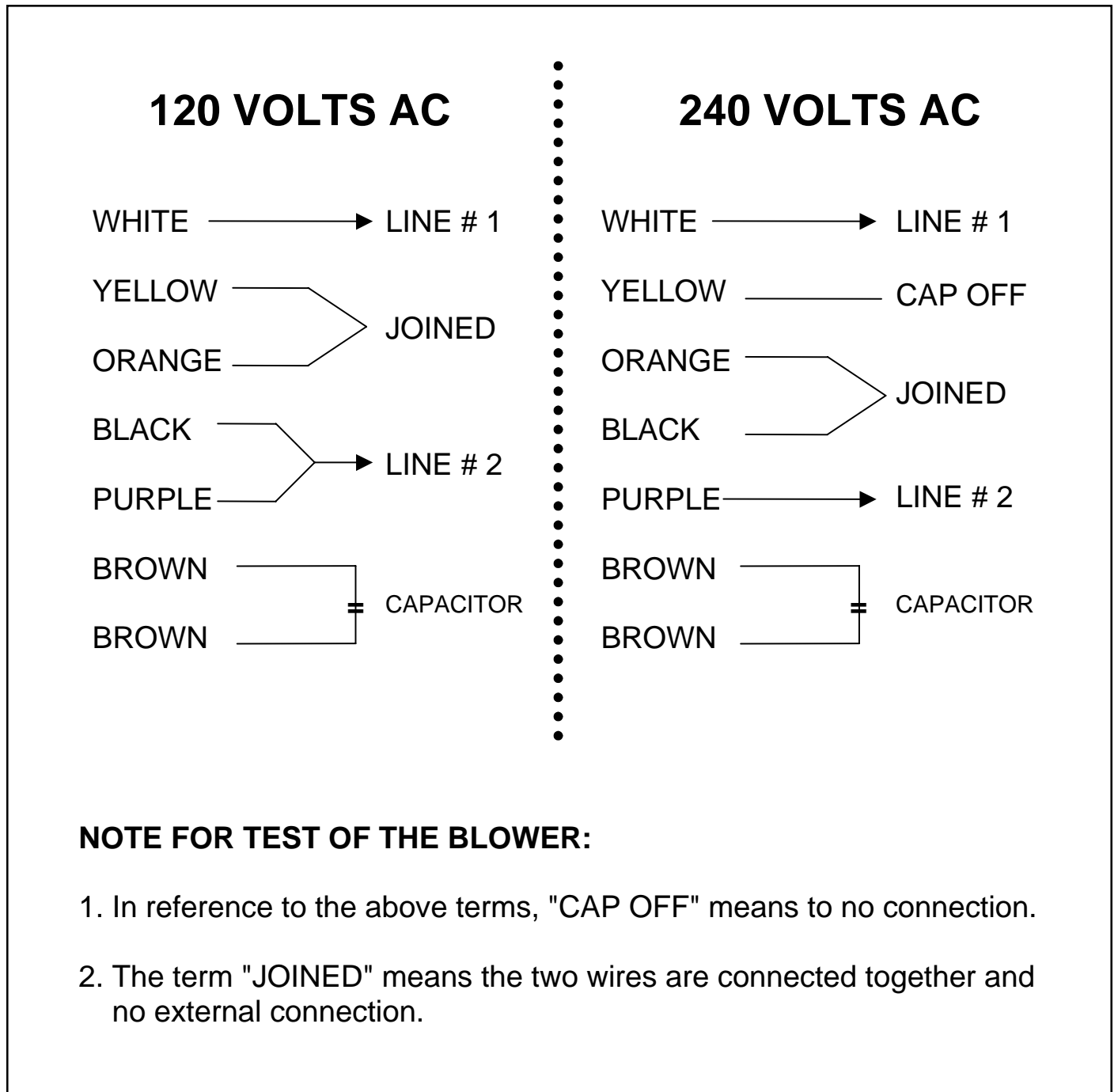
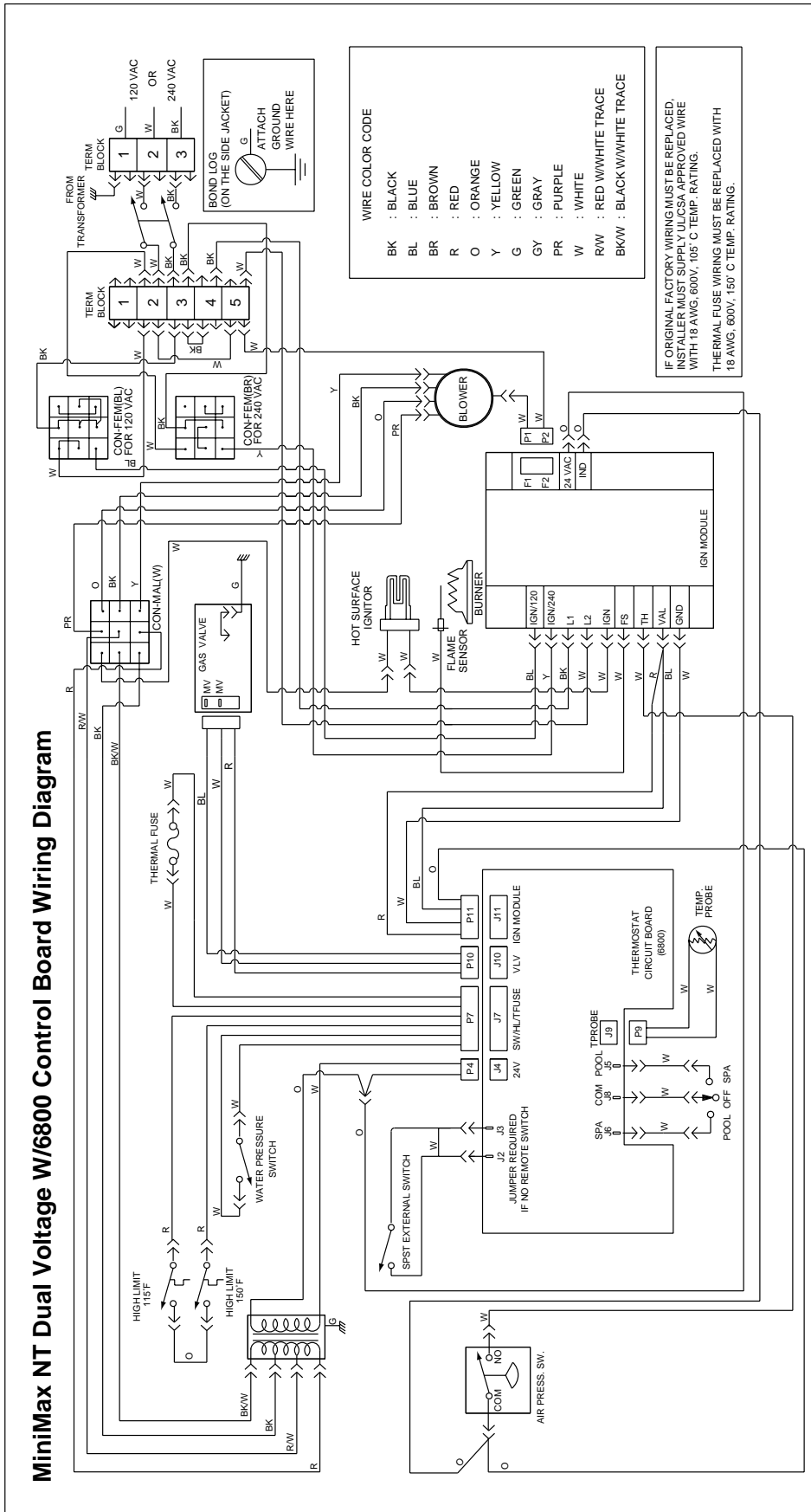

Figure 5.

WIRING SCHEMATIC FOR ALL DUAL VOLTAGE BLOWERS

MiniMax NT HSI Electronic Ignition Wiring Diagram (DUAL VOLTAGE w/6800 Control Board)



SCHEMATIC FOR REMOTE CONTROL

3 Wire Remote

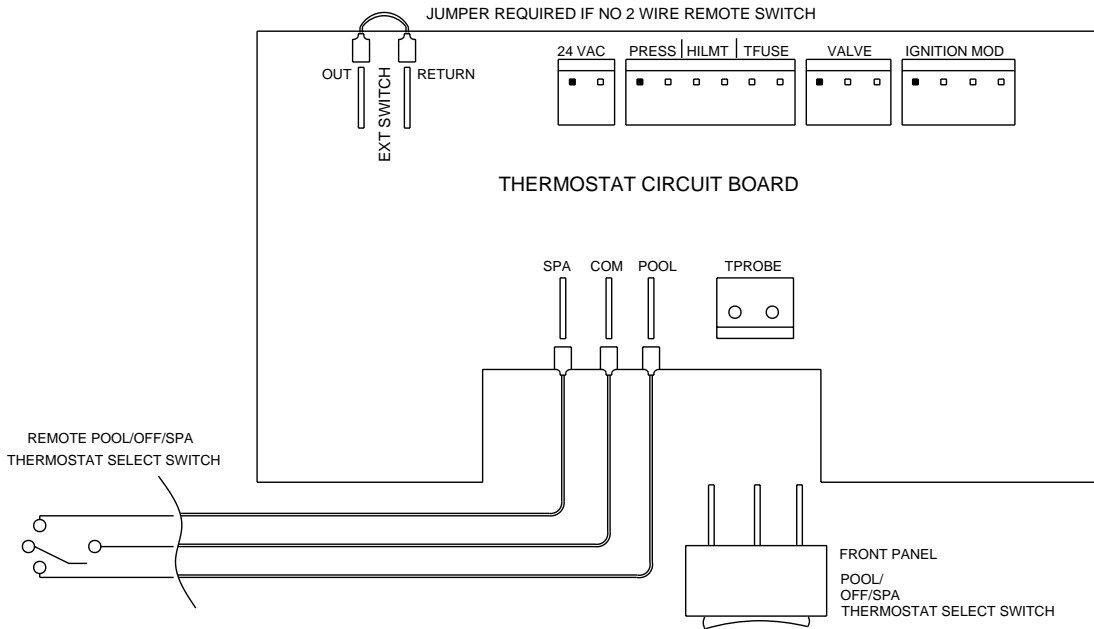

Figure 6.

2 Wire Remote

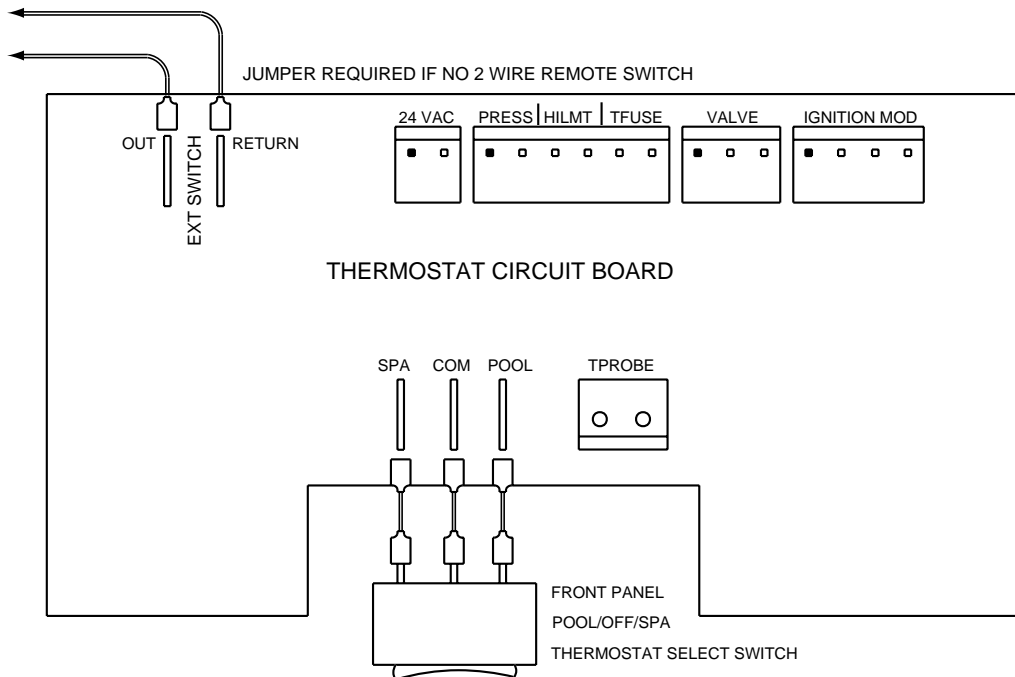

Figure 7.

NOTE: When connecting a remote control to the MiniMax NT Heater, you must install the low voltage thermostat wires in separate conduit from **ANY** line voltage wires. Failure to follow these instructions will cause the thermostat relay to react erratically.

OPERATING (CONTROLS)

Dual Temperature Control System

For convenience and economy all MiniMax NT Heaters are equipped with two thermostats on the front of the heater control panel; see Figure 8.

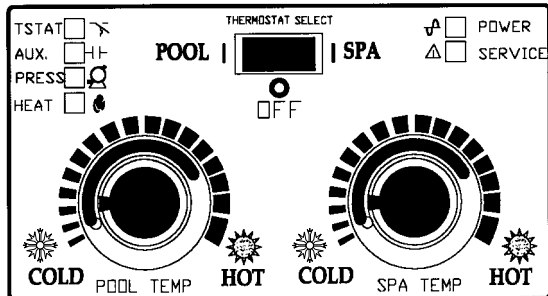

Figure 8.

THERMOSTAT KNOB STOPPER

Each thermostat is equipped with a mechanical stop that can be locked or unlocked with use of a screwdriver to prevent temperatures in excess of that desired by the user; see Figure 9.

The maximum setting can be adjusted by loosening the screw "A" and turning the stopper dial to desired maximum setting. Lock the setting by tightening the screw. The Mechanical stop is under the knob. Ensure that the knob is stopping at the correct position when the knob is rotated clockwise from a lower temperature position. (See Thermostat Adjustment.)

NOTE

To eliminate error due to piping heat losses, measure pool temperature with an accurate thermometer directly at the pool or spa.

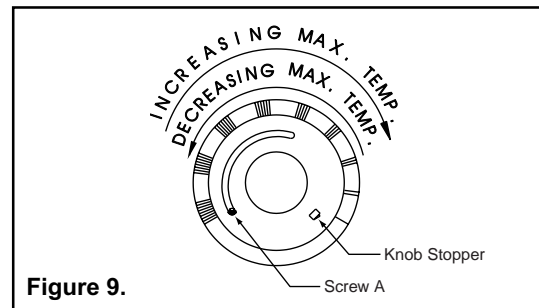

Figure 9.

POWER (THERMOSTAT SELECT) SWITCH

The Pool/Off/Spa switch allows the heater to be turned off when heating is not desired.

1. "Pool" position - Maintains selected pool temperature.
2. "Off" position - Heater will not come on regardless of drop in pool or spa temperature.
3. "Spa" position - This allows separate control of spa water temperature.

INDICATOR LIGHT DESCRIPTION

The MiniMax NT Heater provides nine status indicator lights, six can be seen from the front of the control panel which help you understand the operation of the heater. If something should go wrong, the lights will aid in troubleshooting the problem. Three additional lights can be seen after opening the control panel. These three lights give the service technician advanced troubleshooting capability. All the LED lights are green with the exception of the red service LED.

POWER LIGHT (POWER)

The light is on at all times, in any switch position, indicating 24 VAC power is being supplied to the control circuit. If it fails to light, no other light will be on. Possible causes are: a) external power to the heater is disconnected, check service panel circuit breaker or fuses; b) local circuit breaker inside the transformer has tripped -- investigate cause before resetting; c) transformer has failed.

THERMOSTAT (TSTAT)

This light is on when the thermostat contacts close, signaled by the water temperature falling below the setpoint, calling for the heater to fire to maintain the desired water temperature.

AUXILIARY (AUX)

This light is on when it indicates the remote switch contacts are closed. This allows you to observe if your remote switch is properly closing the heater control circuit. When shipped from the factory a jumper is installed to maintain closed circuit in the absence of a remote switch.

PRESSURE (PRESS)

This light is on when Spa/Pool Selector switch is on, indicates the circulation pump is running properly. If pressure light fails to light, the pump may have lost its prime or water flow may be restricted by an inadvertently closed valve or clogged filter or pump basket. If you have determined that there is no water flow restriction to the heater, you should call a qualified serviceman.

HEAT (HEAT)

The heat light is on any time the thermostat has signaled a call for heat which initializes the ignition safety firing circuit -- the light comes on to indicate successful firing of the main burners.

SERVICE (SERVICE)

The service light is off during normal operation of heater. The light only comes on if a problem with a control has occurred or when the heater is first firing. The problem must be investigated by a qualified service technician prior to attempts to fire the heater again.

The diagrams that follow give examples of troubleshooting a malfunctioning heater using the assistance of the indicator lights.



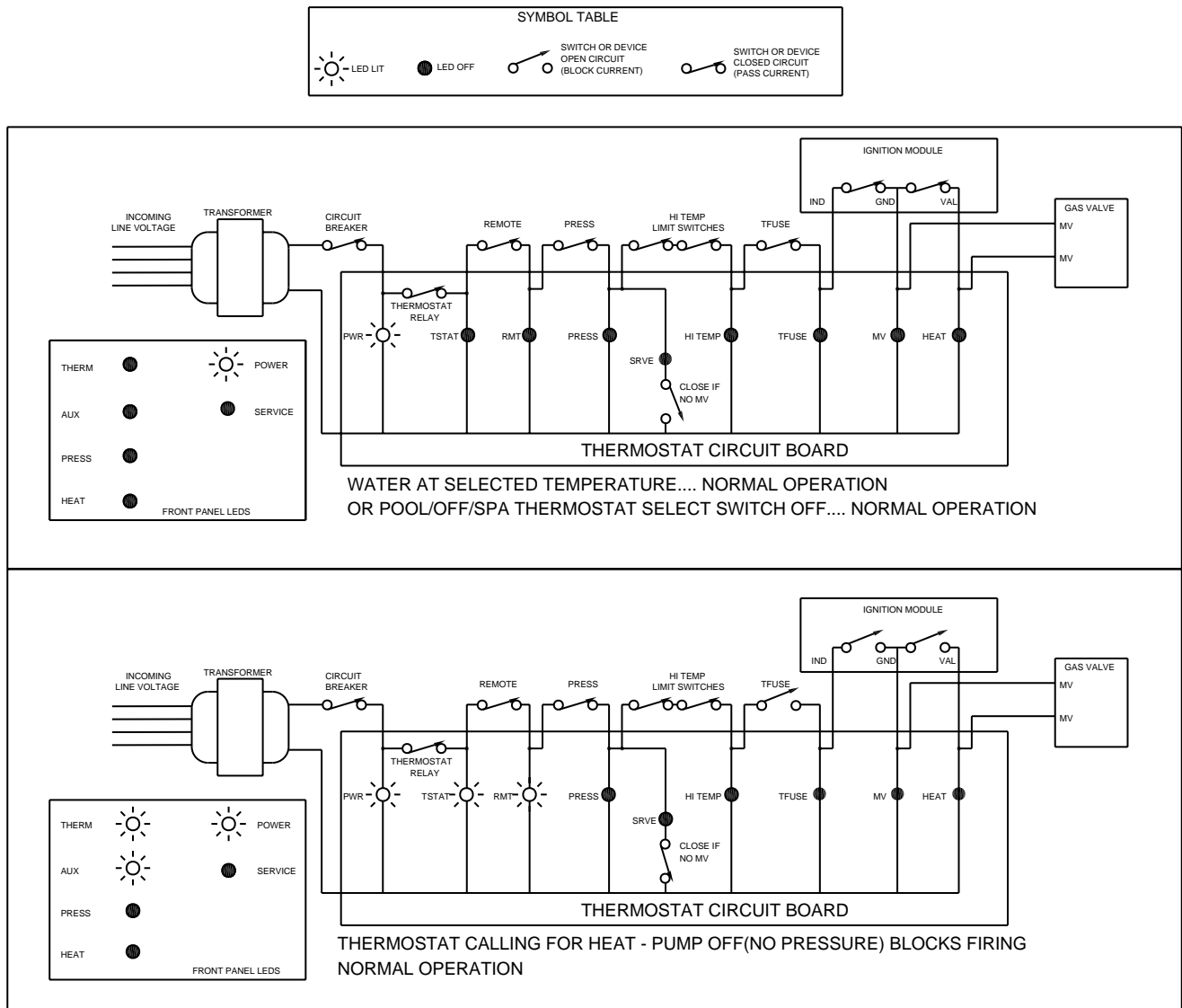

TROUBLESHOOTING (CONTROLS)

Example of troubleshooting with the assistance of the indicator lights.



TROUBLESHOOTING (CONTROLS) - Continued

SYMBOL TABLE

 LED LIT	 LED OFF	 SWITCH OR DEVICE OPEN CIRCUIT (BLOCK CURRENT)	 SWITCH OR DEVICE CLOSED CIRCUIT (PASS CURRENT)
---	---	---	--

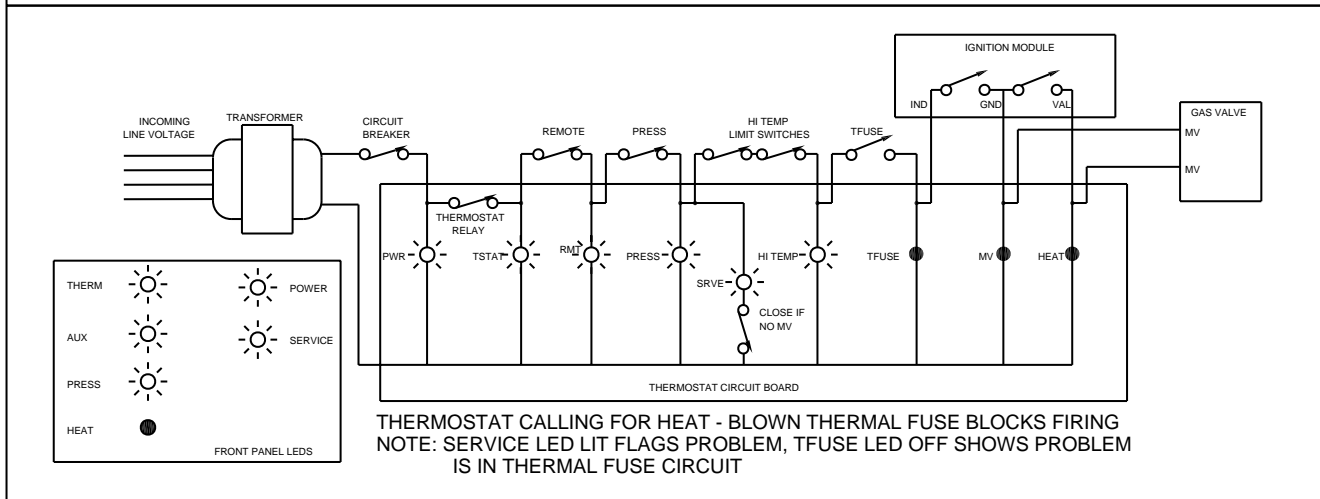
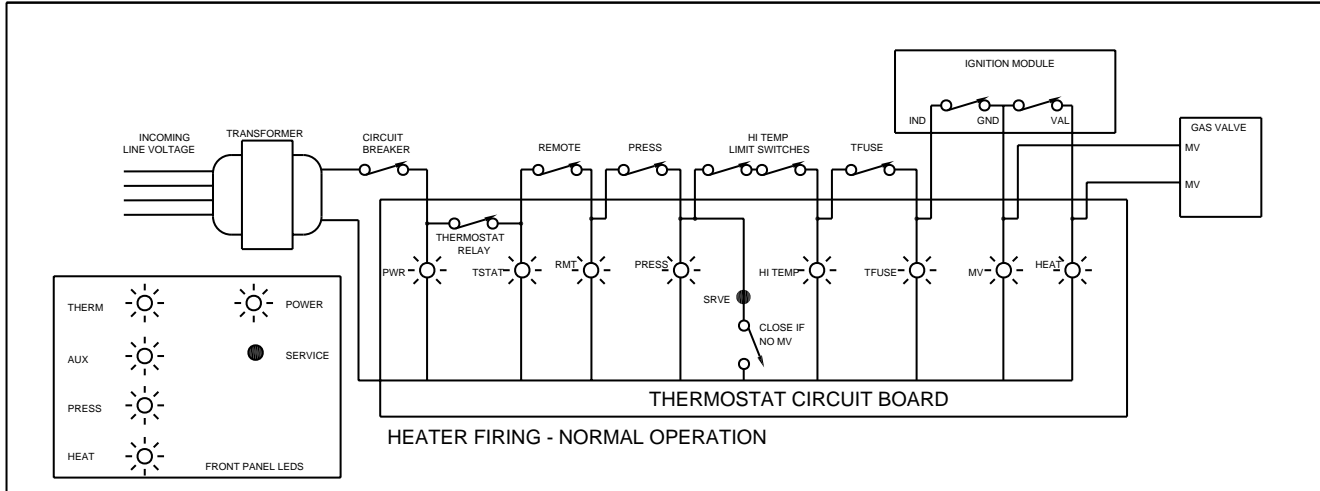

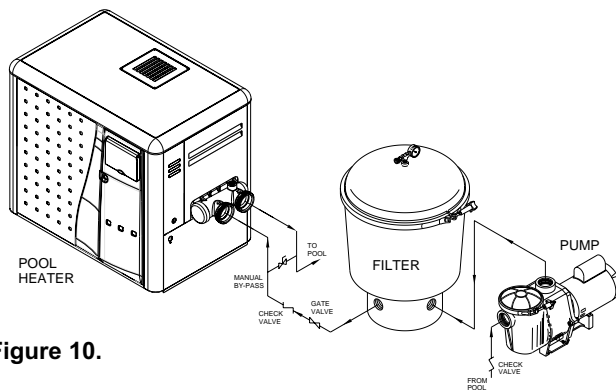

Figure 10.

PLUMBING CONNECTIONS

The MiniMax NT heater has the unique capability of direct schedule 40 PVC plumbing connections. A set of bulkhead fittings is included with the MiniMax NT to insure conformity with Pentair’s recommended PVC plumbing procedure. Other plumbing connections can be used. See Figure 10 for plumbing connections.

CAUTION

Before operating the heater on a new installation, turn on the circulation pump and bleed all the air from the filter using the air relief valve on top of the filter. Water should flow freely through the heater.

Do not operate the heater unless water in the pool/spa is at the proper level.

PLUMBING

VALVES

When any equipment is located below the surface of the pool or spa, valves should be placed in the circulation piping system to isolate the equipment from the pool or spa. Check valves are recommended to prevent back siphon.

CAUTION

Exercise care when installing chemical feeders so as to not allow back siphoning of chemical into the heater, filters or pump. When chemical feeders are installed in the circulation of the piping system, make sure the feeder outlet line is down stream of the heater, and is equipped with a positive seal noncorrosive “Check Valve”, (P/N R172288), between the feeder and heater.

MANUAL BY-PASS

Where the flow rate exceeds the maximum 120 GPM, a manual bypass should be installed and adjusted. After adjustments are made, the valve handle should be removed to avoid tampering.

Model	Min. (GPM)	Max. (GPM) *
200	20	120
250	30	120
300	30	120
400	40	120

* Do not exceed the maximum recommended flow rate for the connecting piping.

See Page 25, Figure 21.

BELOW POOL INSTALLATION

If the heater is below water level, the pressure switch must be adjusted. This adjustment must be done by a qualified service technician. See following CAUTION before installation.

CAUTION

BELOW OR ABOVE POOL INSTALLATION

The water pressure switch is set in the factory at 1½ PSI. This setting is for a heater installed at pool level or within 3’ above or 3’ below. If the heater is to be installed more that 3’ above or 3’ below, the water pressure switch must be adjusted by a qualified service technician.

FLOW SWITCH

If the heater is installed more the 6’ above the pool or more than 10’ below the pool level, you will be beyond the limits of the pressure switch and a flow switch must be installed. Locate and install the flow switch externally on the outlet piping from the heater, as close as possible to the heater. Connect the flow switch wires in place of the water pressure switch wires.

WATER CONNECTIONS

Reversible Inlet/Outlet Connection

The MiniMax NT heater is factory assembled with right side inlet/outlet water connections. The inlet/outlet header can be reversed for left side water connections without removing the heat exchanger.

Reversing Water Connections

Tools required:

- 1/4 in. Screw Driver
- 9/16 in. Socket and Wrench
- 1/2 in. & 9/16 in. Open Wrench

1. Remove the right and left large inspection plates.
2. Disconnect all wires from the high-limit switches except the short jumper wire.

NOTE

There is no reason to **remove** the high-limit and pressure switches or the thermister from the front header during the reversing procedure, as they will be in the proper location when installed on the left side.

3. Disconnect the pressure switch wiring.
4. Remove the temperature sensing bulb from the inlet/outlet header. **Note:** If needed, you may cut the wire ties holding them together.
5. Remove the 16 bolts holding the main inlet/outlet head and return head in place, exchange the heads, using the new tube seals supplied with the heater, re-install the 16 bolts using moderate torque.
6. Install the temperature sensing probe by passing the wires through the hole provided on the left side of the brace panel. Route wires through the support bracket.
7. Reconnect all the high limit wires and the pressure switch wiring, routing the wires through the same hole as the thermostat sensor wires.
8. Re-install the two large inspection plates on the appropriate side.

INSULATING THE HIGH LIMITS

When Reversing Heads on the MiniMax NT Heater

On the MiniMax NT heater there is insulation installed by the factory on the return head side of the heaters. This insulation is there so that if the heads are reversed in the field, during initial installation of the heater, the reflected heat from the flue collector will be insulated from the high limits.

*Return head in position before removal.
This view shows the insulation installed by the factory.*

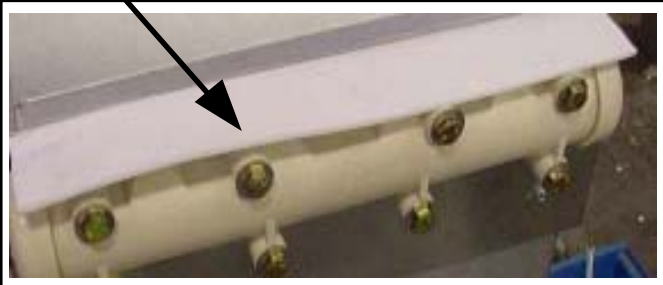

*Return head removed and new tube seals installed.
Now ready to accept the installation of the main head.*

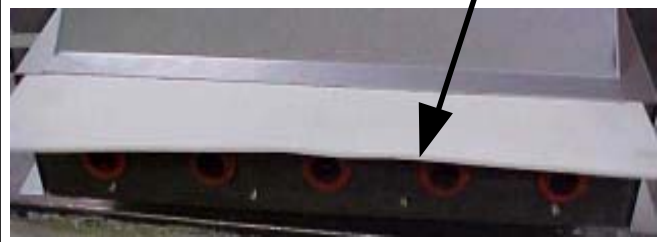

*Lift the installation to allow the main head to be installed.
When head is placed into position, release the insulation;
it will now shield the high limits from the heat produced
by the flue collector.*

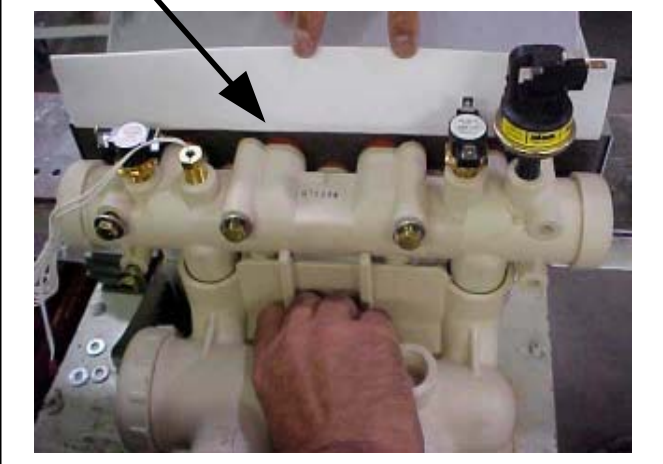

GAS CONNECTIONS

GAS LINE INSTALLATIONS

Before installing the gas line, be sure to check which gas the heater has been designed to burn. This is important because different types of gas require different gas pipe sizes. The rating plate on the heater will indicate which gas the heater is designed to burn. Tables 1-3, shown on [page 18](#), shows which size pipe is required for the distance from the gas meter to the heater. The table is for natural gas at a specific gravity of .65 and propane at a specific gravity of 1.5.

When sizing gas lines, calculate three (3) additional feet of straight pipe for every elbow used.

When installing the gas line, avoid getting dirt, grease or other foreign material in the pipe as this may cause damage to the gas valve, which may result in heater failure.

The gas meter should be checked to make sure that it will supply enough gas to the heater and any other appliances that may be used on the same meter.

The gas line from the meter will usually be of a larger size than the gas valve supplied with the heater. Therefore a reduction of the connecting gas pipe will be necessary. Make this reduction as close to the heater as possible.

The heater and any other gas appliances must be disconnected from the gas supply piping system during any pressure testing on that system, (greater than ½ PSIG).

The heater and its gas connection must be leak tested before placing the heater in operation. **Do not use flame to test the gas line.** Use soapy water or another nonflammable method.

A manual main shut-off valve must be installed externally to the heater.

⚠ WARNING

DO NOT INSTALL THE GAS LINE UNION INSIDE THE HEATER CABINET. THIS WILL VOID YOUR WARRANTY.

SEDIMENT TRAPS

Install a sediment trap in front of the gas controls. The sediment trap shall be either a tee fitting with a capped nipple in the bottom outlet which can be removed for cleaning, as illustrated in Figure 11, or a other device recognized as an effective sediment trap. All gas piping should be tested after installation in accordance with local codes.

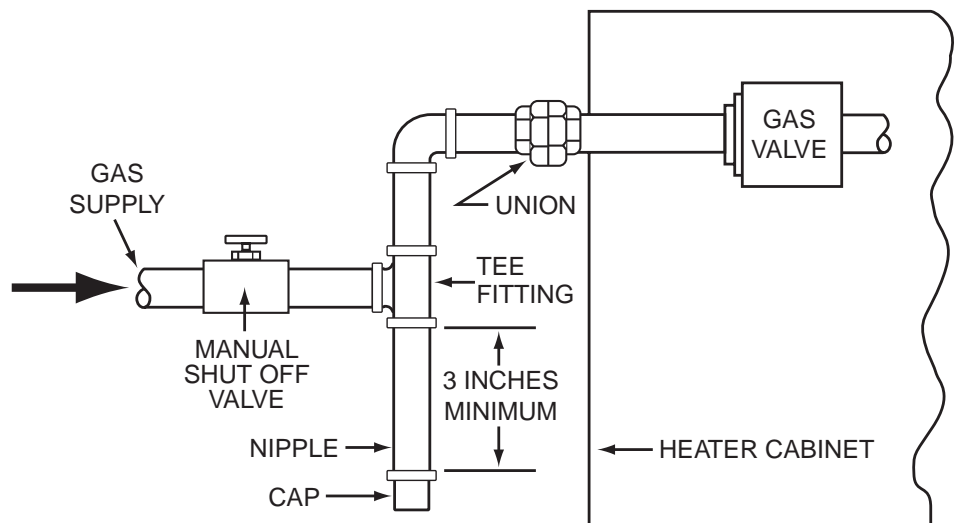

Figure 11.

Pipe Sized For Length Of Run In Equivalent Feet

Table 1.

PIPE SIZING FOR GAS LINE CONNECTIONS														
MAXIMUM EQUIVALENT PIPE LENGTH														
Natural gas at 1000 B.T.U. per Cubic Foot														
Propane Gas at 2500 B.T.U. per Cubic Foot														
MODEL	1/2"		3/4"		1"		1-1/4"		1-1/2"		2"		2-1/2"	
	NAT	PRO	NAT	PRO	NAT	PRO	NAT	PRO	NAT	PRO	NAT	PRO	NAT	PRO
200	-	20'	30'	80'	125'	250'	450'	600'	-	-	-	-	-	-
250	-	10'	20'	50'	70'	150'	250'	500'	600'	-	-	-	-	-
300	-	-	10'	30'	50'	100'	200'	350'	400'	600'	-	-	-	-
400	-	-	-	10'	20'	60'	100'	150'	200'	450'	400'	-	-	-

PROPANE 2 STAGE REGULATION

In many "RESIDENTIAL" Propane gas line installations, the gas supplier and or installer will utilize a two stage regulation process where by at the supply tank they will install the first stage gas regulator, which would be at a higher pressure, usually 10 psi and can be for longer distance and in a smaller pipe size. Then within a short distance from the heater they will install a second regulator, which is the second stage, and this would be set at the required inlet pressure of 11 inches of W.C. for all the Pentair Pool Heaters.

Stage One "High Pressure" Gas Pipe Sizing			
MAXIMUM EQUIVALENT PIPE LENGTH			
Model	0 to 50 Feet	50 to 100 Feet	100 to 150 Feet
200	1/2 in.	1/2 in.	1/2 in.
250	1/2 in.	1/2 in.	1/2 in.
300	1/2 in.	1/2 in.	1/2 in.
400	1/2 in.	1/2 in.	1/2 in.

Table 2.

Stage Two "Low Pressure" Gas Pipe Sizing		
MAXIMUM EQUIVALENT PIPE LENGTH		
Model	0 to 10 Feet	10 to 20 Feet
200	1/2 in.	3/4 in.
250	1/2 in.	3/4 in.
300	3/4 in.	3/4 in.
400	3/4 in.	3/4 in.

Table 3.

REGULATED MANIFOLD PRESSURE TEST

1. Attach the manometer to the heater jacket.
2. Shut off the main gas valve.
3. Remove 1/8 in. NPT plug on the outlet side of the valve and screw in the fitting from the manometer kit. See Figure 12.
4. Connect the manometer hose to the fitting.
5. Turn on the heater.
6. The manometer must read 4 in. WC for natural gas or 11 in. WC for propane, **while** operating.
7. For adjustment, remove the Regulator Adjustment Cap and using a screwdriver turn the screw clockwise to increase - counterclockwise to decrease gas pressure.

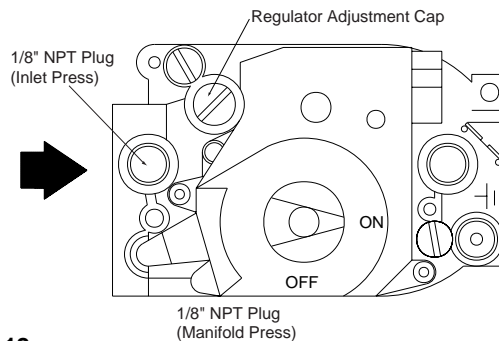

Figure 12.

MINIMAX NT GAS PRESSURE REQUIREMENTS*

	Natural	Propane
Maximum inlet gas pressure	10 in. WC	14 in. WC
Minimum inlet gas pressure	**5 in. WC	12 in. WC
Normal manifold pressure	4 in. WC	11 in. WC

*All Readings are taken with the heater fired. Any adjustments or readings made with heater off will give incorrect readings.
 ** 6 in. WC for 400 model

CAUTION

The use of Flexible Connectors (FLEX) is **NOT** recommended as they cause high gas pressure drops.

INDOOR VENTING—General Requirements

The vent pipe must be the same size or larger. The MiniMax NT heaters are capable of a 360-degree discharge rotation and operate with a positive vent static pressure and with a vent gas temperature less than 400° F.

Please note the allowable vent runs for each stack pipe diameter are different and can not be exceeded. The total length of the horizontal run must not exceed the length that is listed below in the tables.

Note that each 90-degree elbow reduces the maximum horizontal vent run by 8 feet and each 45-degree elbow in the vent run reduces the maximum vent run by 4 feet. See the tables below for the maximum vent lengths using a 90-degree and 45-degree elbows.

The MiniMax NT is a “Category III” Appliance and is an induced-draft pool and spa heater which uses positive pressure to push flue gases through the vent pipe to the outside. This requires a completely sealed vent system—single wall vent pipe with sealed-seams and joints. **Flue gases under positive pressure may escape into the dwelling with any cracks or loose joints in the vent pipe, or improper vent installation.** The vent pipe must be of a sealed-seam construction such as those listed for use with “Category III Appliances” and for operating temperatures above 350°. The use of listed thimbles, roof jacks and/or side vent terminals are required; and the proper clearances to combustible materials must be maintained in accordance with type of vent pipe employed—in the absence of a clearance recommendation by the vent pipe manufacturer, the requirements of the Uniform Mechanical Code should be met. **The ventilation air requirements for the MiniMax NT heater can be found on page 21.** It is recommended that vent runs over 18 feet be insulated to reduce condensation related problems and/or the use of a condensate trap in the vent run close to the heater may be necessary in certain installations such as cold climates. The MiniMax NT is suitable for through-the-wall venting, see table and dimensions below.

Recommended sources for Side-wall vent hood terminals include: The Field Controls Co. (2308 Airport Road, Kingston, NC 28501, (800)742-8368) and Tjernlund Products Inc. (1601 Ninth Street, White Bear Lake, MN 55110, (800) 255-4208)—consult manufacturer for model information and availability.

⚠ CAUTION

Do NOT combine exhaust vent pipes to a common exhaust vent in multiple unit installations. Run separate vent pipes.

45 ft. Maximum Vent Run, 5 in. O.D. vent (Equiv. ft.)			
Additional 90° elbows after first elbow		Additional 45° elbows after first elbow	
Quantity	Reduced Max.	Quantity	Reduced Max.
1 (2 total)	37	(2 total)	41
2 (3 total)	29	(3 total)	37
3 (4 total)	21	(4 total)	33

22 ft. Maximum Vent Run, 4 in. O.D. vent (Equiv. ft.)			
Additional 90° elbows after first elbow		Additional 45° elbows after first elbow	
Quantity	Reduced Max.	Quantity	Reduced Max.
1 (2 total)	14 ft.	(2 total)	18 ft.
2 (3 total)	—	(3 total)	14 ft.
3 (4 total)	—	(4 total)	—

THROUGH WALL VENT KITS FOR HEATERS						
Part Number	Dim. A	Dim. B	Dim. C	Dim. D	Dim. E	Dim. F
471532	4 in. Dia.	6 in. Dia.	8½ in.	6 5/16 in.	12 5/8 in.	10 5/8 in.
471543	5 in. Dia.	8 in. Dia.	8½ in.	8 in.	12 5/8 in.	10 5/8 in.

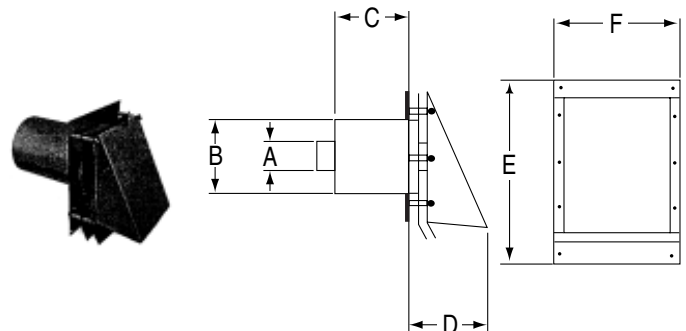

INDOOR INSTALLATION (USA ONLY)
OUTDOOR SHELTER INSTALLATION (CANADA)

See page 21 for (Indoor) Vent Adaptors

All products of combustion and vent gases must be completely removed to the outside atmosphere through a vent pipe which is connected to the stack adaptor. A vent pipe extension of the same size must be connected to the indoor stack adaptor and extended at least 2 feet higher than highest point of the roof within a 10 foot horizontal radius, and at least 3 feet higher than the point at which it passes through the roof, or as permitted by local code; see Figures 13, 14 and Detail “H” of Figure 18. The vent should terminate with an approved vent cap (weather cap) for protection against rain or blockage by snow.

The heater must be located as close as practical to a chimney or gas vent.

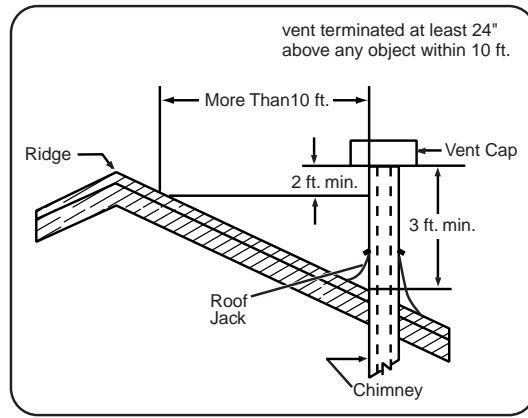

Figure 13.

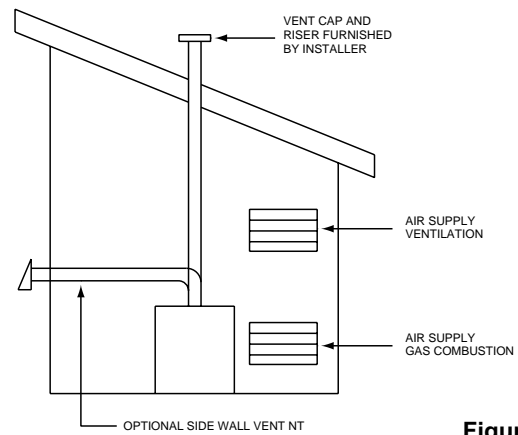

Figure 14.

⚠ CAUTION

The heater should be installed at least 5 feet away from the pool or spa.

The heater must be placed in a suitable room on a non-combustible floor or on a non-combustible base and in an area where leakage from heat exchanger or water connections will not result in damage to the area adjacent to the heater or the structure. When such locations cannot be avoided, it is recommended that a suitable drain pan with adequate drainage, be installed under the heater. The pan must not restrict air flow.

Installations in basements, garages, or underground structures where flammable liquids may be stored must have the heater elevated 18 inches from the floor using a non-combustible base. The following minimum clearances from combustible materials must be provided.

	Side	Front	Back	Top
Water Connection	18 in.	24 in.	-	-
Remaining	6 in.	-	6 in.	-
Ceiling Clearance	-	-	-	18 in.*

*To ceiling or roof.

The heater should not be installed closer than 6 inches to any fences, walls or shrubs at any side or back, nor closer than 18 inches at the plumbing side. A minimum clearance of 24 inches must be maintained at the front of the heater.

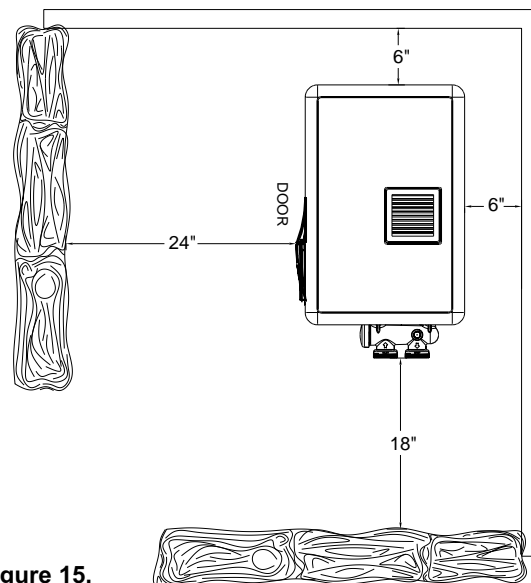

Figure 15.

NOTE

- The heater requires **two uninterrupted air supply openings**; one for ventilation and one to supply air for proper gas combustion. The air supply openings should be sized according to Table 4.
- The openings listed in Table 4. are free open vent area—if the vents incorporate restrictive louvers, the vent openings must be increased to compensate for the area blocked by the louvers (or grills).

Air supply requirements below apply to all MiniMax NT heaters

Model	REQUIRED AIR SUPPLY	
	Air for Combustion Sq. In.	Air Ventilation Sq. In.
200	200	200
250	250	250
300	300	300
400	400	400

Table 4.

INSTALLATION ON FLOORS CONSTRUCTED OF COMBUSTIBLE MATERIALS

The heater may be placed on a “combustible floor” using either of the two methods listed below:

- Use Listed Factory Non-combustible Base Kit for use on combustible floors.

Model	Non-Combustible Base Kit
200	471961
250	460509
300	471960
400	460508

- Construct a non-combustible base from masonry blocks as illustrated, see Figure 16.

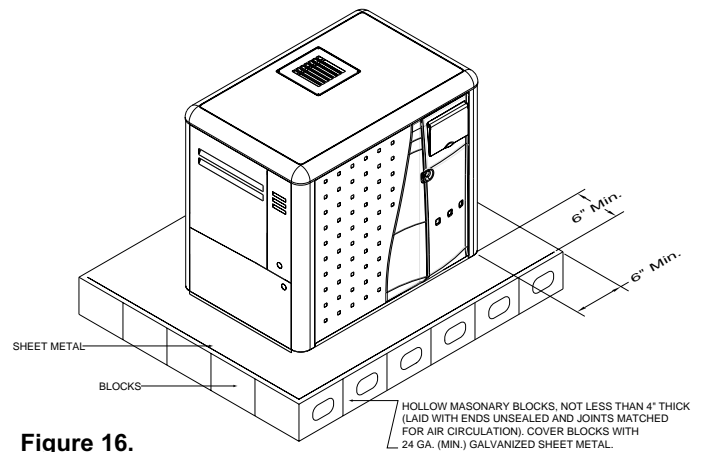

Figure 16.

CAUTION

Chemicals should not be stored near the heater installation. Combustion air can be contaminated by corrosive chemical fumes which can void the warranty.

INDOOR VENT ADAPTORS (ALL MODELS)

The proper draft hood and adaptor must be installed on the heater as shown below and on [pages 19 and 20](#):

Part No.	Vent Dia.
460506	4 in.
460507	5 in.

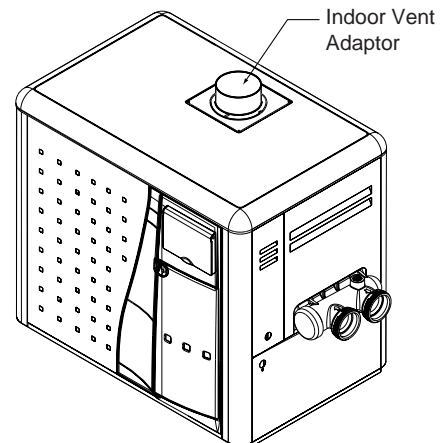
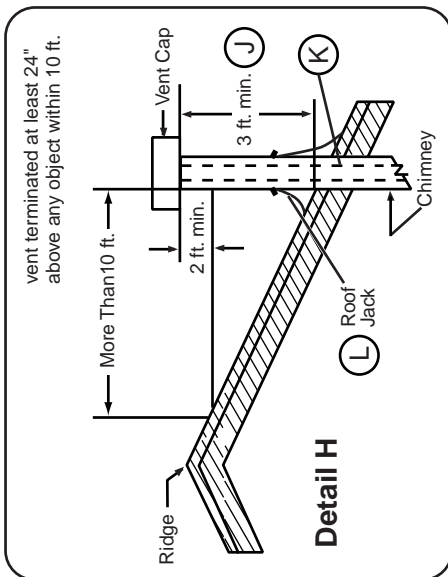

Figure 17.

**INDOOR INSTALLATIONS
MINIMUM VENTING GUIDELINES**



Vent for roof penetration installations:

- (J) must extend at least 3 ft. higher than the point at which it passes through the roof, or as permitted by local code.
- (K) must use a double-wall vent pipe through the roof penetration.
- (L) must terminate with an approved (listed) roof jack, storm collar, and vent/weather cap.

Vent pipe extension:

- must be the same diameter as the vent connector.
- must be suitable for use with category III appliances which have flue gas temperatures of less than 400 deg. F.
- may use a single wall vent pipe with permanently sealed seams and joints.

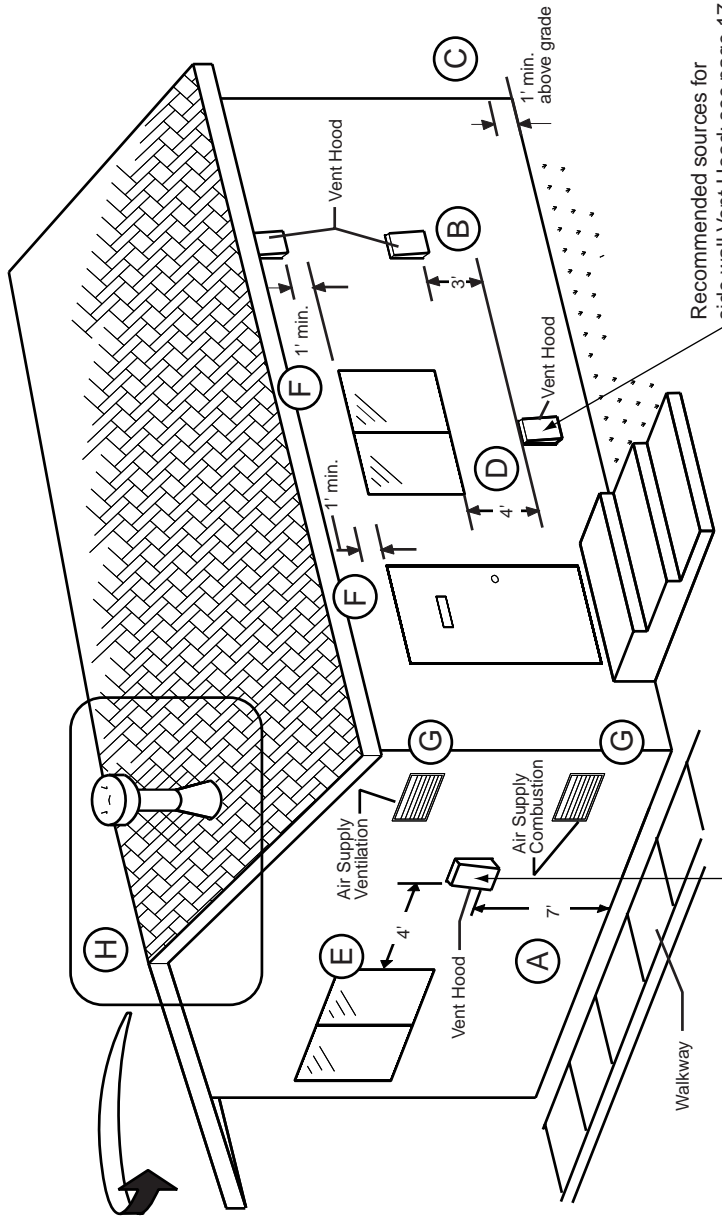

Vent termination for side wall installations:

- (A) must be not less than 7 ft. above public walkways.
- (B) must be at least 3 ft. above any outside air intake located within a 10 ft. radius.
- **must NOT** be within 3 ft. of an inside corner of the structure.
- (C) must be at least 1 ft. above grade.

- must be located the following distances away from any door, window, or gravity air inlet:
 - (D) 4 ft. below
 - (E) 4 ft. horizontally
 - (F) 1 ft. above

Air Supply

- (G) See Air Supply Requirements Table.

(Table 4. on page 21.)

Figure 18.

VENTILATION

OUTDOOR INSTALLATION ONLY (Outdoor Shelter Installation in Canada, see page 20)

For outdoor installation with an exhaust grill, the heater must be placed in a suitable area on a level, noncombustible surface. Do not install the heater under an overhang with clearances less than 3 feet from the top of the heater. The area under an overhang must be open on three sides.

IMPORTANT!

- For an outdoor installation it is important to ensure water is diverted from overhanging eaves with a proper gutter/drainage system. The heater must be set on a level foundation for proper drainage.
- When locating the heater, consider that high winds can roll over or deflect off adjacent buildings and walls. Normally, placing the heater at least three feet from any wall will minimize downdraft.

Maintain minimum clearances as indicated below. Install a minimum of 4 feet below, and 4 feet horizontally from any opening to a building, see Figure 19.

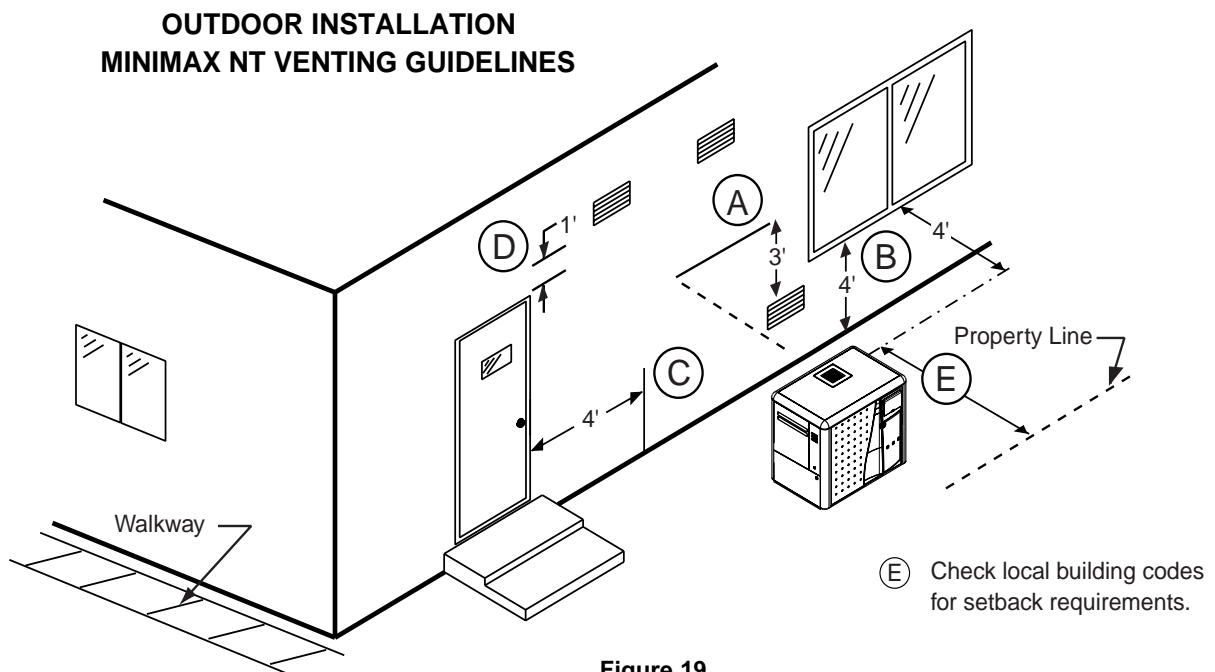

Figure 19.

Vent Termination:

- ★ Must be not less than 7 ft. above public walkways.
- (A) Must be at least 3 ft. above any forced air inlet located within a 10 ft. radius.
- ★ Must be located the following distances away from any door, window, or gravity air inlet:
 - (B) 4 ft. below, or
 - (C) 4 ft. horizontally, or
 - (D) 1 ft. above

GENERAL DESCRIPTION

The MiniMax NT Pool and Spa Heater is a fan-assisted induced draft appliance. The MiniMax NT is available in 200,000, 250,000, 300,000 and 400,000 btu/hr. capacities and are certified for both indoor and outdoor installations.

The MiniMax NT is designed to operate both in stackless outdoor installations or with indoor stack vent installations—the indoor installation may be made using Kit 460506 or 460507; see [pages 7 and 21](#), vertical vent pipe or with a horizontal vent pipe and a Listed side-wall vent.

BASIC SYSTEM OPERATION

TO OPERATE HEATER

1. **Start pump, make sure the pump is running and is primed, to close water pressure switch and supply power to heater.**
2. Set thermostat to lowest setting .
3. Set the thermostat rocker switch to the center “OFF” position.
4. Open the access doors. Set power switch to “OFF”.
5. Push in the gas control knob slightly and turn the knob clockwise to “OFF”.
6. Wait (5) minutes to clear out any gas. If you then smell gas STOP. Follow the safety information (stated earlier in the lighting instructions section). If you don’t smell gas, go to the next step.
7. Turn the knob on the gas control counter clockwise to the “ON” position and set power switch to “ON”.
8. Replace the doors.
9. Push the thermostat select switch to “POOL” or “SPA” to start the heater.
10. Set the thermostat to the desired temperature.
 - a. Fan motor starts, which closes Vacuum Air Pressure (fan) switch.
 - b. Ignition module is energized and the pre-purge cycle is started approximately 15 seconds.
 - c. Check for powering up the (glow coil) hot-surface ignitor by viewing through the opening holes on the face plate.
11. The ignitor will warm up and then gas valve opens to ignite the main burners.
12. Heater will operate until desired temperature is reached.

SAFETY CONTROLS

VACUUM AIR PRESSURE (FAN) SWITCH

The air pressure switch is a safety device used to insure that the combustion air blower (fan) is operating and has been designed to monitor the vacuum (negative) pressure within the blower housing. The air pressure switch is factory set and is connected upstream of the ignition module. The ignition module does not operate unless the air pressure switch and all safety switches are closed.

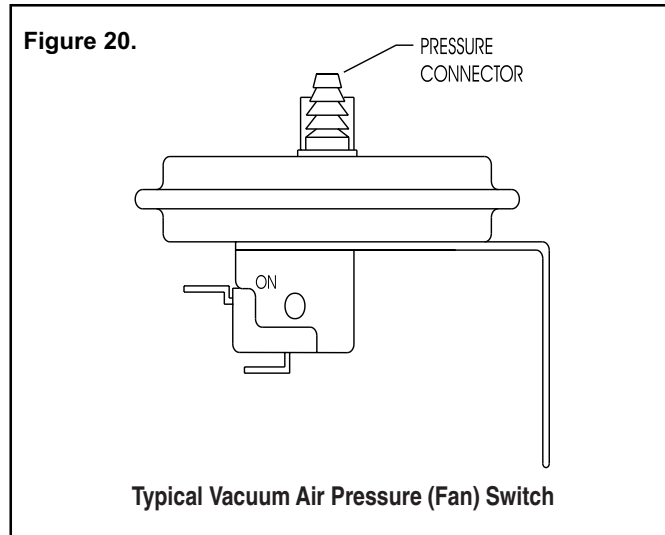

WATER PRESSURE SWITCH

The water pressure switch closes when there is a sufficient flow of water to the heat exchanger to safely operate the heater. The switch has been preset by the Factory at 1 PSIG for operation. **NOTE:** See, *Below Pool Level Installation instructions on page 15*. The switch may remain closed with no water flow if there is more than a 3 feet elevation difference between the heater (heat exchanger) and the pool water line—if this is the case, the water pressure switch must be reset by a qualified service technician to maintain open switch contacts with no water flow.

NOTE

If the pool is more than one floor above or one floor below the heater, the pressure switch may have to be replaced with a flow switch.

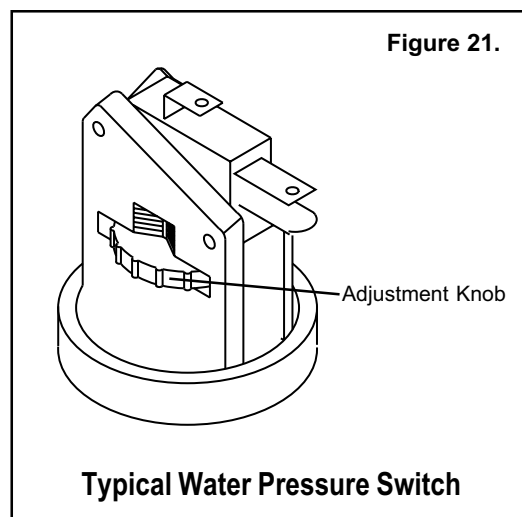

SAFETY CONTROLS, (cont'd.)

IGNITION MODULE

The Ignition Module is microprocessor based and operates on 24 VAC supplied by the transformer. The control utilizes a microprocessor to continually and safely monitor, analyze, and control the proper operation of the gas burners. The module with the presence of the flame sensor, using flame rectification, allows the heater to operate.

HIGH LIMITS

A “High Limit”, is a safety device that opens the electrical circuit and shuts off the heater based on a water temperature set point within the “High Limit Device”. The MiniMax NT series of heaters contains two (2) high limit devices which are located on the main inlet / outlet header, one sensing the inlet water temperature and one sensing the outlet water temperature.

OPERATION OF IGNITION MODULE

HEAT MODE

- When a call for heat is received from the thermostat supplying 24 VAC to the module terminal, the control will perform a self check routine and begins the safety timing ignition sequence. After the fan pre-purge cycle, the hot surface ignitor is activated for a heat-up period followed by energization of the gas valve for the trial for ignition period.
- When flame is detected during the trial for ignition, the ignitor is deactivated and the gas valve remains energized. The thermostat and main burner flame are constantly monitored to assure the system continues to operate properly. When the thermostat is satisfied and the demand for heat ends, the main valve is de-energized immediately followed by a fan post purge cycle.

FAILURE TO LIGHT LOCK OUT

Should the main burners fail to light, or flame is not detected during the trial for ignition period of (7) seconds, the ignition Module will stop the ignition sequence and the gas valve will be turned off. The ignition module will go through this sequence three (3) times, if full ignition fails after the third try, the module will go to full lock out. To restart the ignition sequence, turn the main electrical power off to the heater, using the switch on the bottom of the junction box, for a period of one minute, then turn the power back on, the heater will again try to light.

FLAME FAILURE—RE-IGNITION

If the established flame signal is lost while the burner is operating, the control will respond within 1 second. The gas valve is de-energized and the control starts a new ignition sequence in an attempt to relight the burner. If the burner does not relight, the control will go into lockout, requiring a manual reset.

MAINTENANCE INSTRUCTIONS

It is recommended that you check the following items at least every six months and at the beginning of every swimming season.

1. Examine the venting system. Make sure there are no obstructions in the flow of combustion and ventilation air.
2. Visually inspect the main burner and the hot surface ignitor. The normal color of the flame is blue. When flame appears yellow, burners should be inspected and cleaned. Check ignitor for damage.
3. Keep the heater area clear and free from combustibles and flammable liquids.

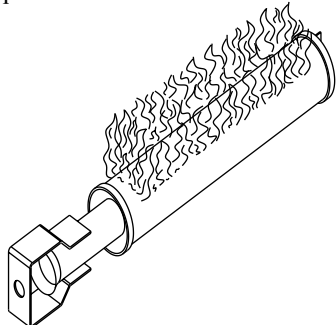

Figure 22.

CAUTION

REMOVE THE FLOW VALVE ASSEMBLY WHEN DRILLING THE HOLE TO INSTALL A PRV, OTHERWISE, YOU WILL DRILL INTO THE VALVE ASSEMBLY.

Pressure Relief Valve
In some installations, a pressure relief valve (PRV) is required on the MiniMax NT. To install a PRV, carefully drill a 3/8 in. hole in center of 3/4 in. NPT port (on main header) being careful to drill only through wall at bottom of 3/4 in. NPT port and no deeper—now thread in the 3/4 NPT PRV.

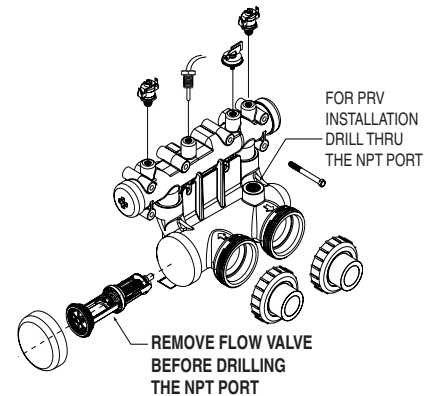

Figure 23.

NOTE: (A.S.M.E. version varies from illustration. It is of bronze construction, and is supplied with the A.S.M.E. Section IV, pressure relief valve pre-installed at factory.) Test the relief valve at least once a year by lifting up lever.

ENERGY SAVING TIPS

1. If possible, keep pool or spa covered when not in use. This will not only cut heating costs, but also keep dirt and debris from settling in the pool and conserve chemicals.
2. Reduce the pool thermostat setting to 78° F. or lower. This is accepted as being the most healthy temperature for swimming by the American Red Cross.
3. Use an accurate thermometer.
4. When the proper maximum thermostat settings have been determined, tighten the thermostat knob stopper.
5. Set time clock to start circulation system no earlier than daybreak. The swimming pool loses less heat at this time.
6. For pools that are only used on the weekends, it is not necessary to leave the thermostat set at 78° F. Lower the temperature to a range that can be achieved easily in one day. Generally, this would be 10° F. to 15° F., if pool heater is sized properly.
7. During the winter or while on vacation, turn the heater off.
8. Set up a regular program of preventative maintenance for the heater each new swimming season. Check heat exchanger, controls, burners, operation, etc.

SPRING AND FALL OPERATION

If the pool is being used occasionally, do not turn the heater completely off. Set the thermostat down to 65° F. This will keep the pool and the surrounding ground warm enough to bring the pool up to a comfortable swimming temperature in a shorter period of time.

WINTER OPERATION

CAUTION

OPERATING THIS HEATER CONTINUOUSLY AT WATER TEMPERATURE BELOW 68° F. WILL CAUSE HARMFUL CONDENSATION AND WILL DAMAGE THE HEATER AND WILL VOID THE WARRANTY.

If the pool won't be used for a month or more, turn the heater off at the main gas valve. For areas where there is no danger of water freezing, water should circulate through the heater all year long, even though you are not heating your swimming pool. **The MiniMax NT should not be operated outdoors at temperatures below 0° F. for propane and -20° F. for natural gas.** Where freezing is possible, it is necessary to drain the water from the heater. This may be done by opening the drain valve, located at the inlet/outlet header (see Figure 23.), allowing all water to drain out of the heater. It would be a good practice to use compressed air to blow the water out of the heat exchanger. *(See additional notes under Important Notices in Introduction.)*

CHEMICAL BALANCE

POOL AND SPA WATER

Your Pentair Pool Products pool heater was designed specifically for your spa or pool and will give you many years of trouble-free service, provided you keep your water chemistry in proper condition.

Three major items that can cause problems with your pool heater are: improper pH, disinfectant residual, and total alkalinity. These items, if not kept properly balanced, can shorten the life of the heater and cause permanent damage.

CAUTION

Heat exchanger damage resulting from chemical imbalance is not covered by the warranty.

WHAT A DISINFECTANT DOES

Two pool guests you do not want are algae and bacteria. To get rid of them and make pool water sanitary for swimming - as well as to improve the water's taste, odor and clarity - some sort of disinfectant must be used.

Chlorine and bromine are universally approved by health authorities and are accepted disinfecting agents for bacteria control.

WHAT IS A DISINFECTANT RESIDUAL?

When you add chlorine or bromine to the pool water, a portion of the disinfectant will be consumed in the process of destroying bacteria, algae and other oxidizable materials. The disinfectant remaining is called chlorine residual or bromine residual. You can determine the disinfectant residual of your pool water with a reliable test kit, available from your local pool supply store.

You must maintain a disinfectant residual level adequate enough to assure a continuous kill of bacteria or virus introduced into pool water by swimmers, through the air, from dust, rain or other sources.

It is wise to test pool water regularly. Never allow chlorine residual to drop below 0.6 ppm (parts per million). The minimum level for effective chlorine or bromine residual is 1.4 ppm.

pH - The term pH refers to the acid/alkaline balance of water expressed on a numerical scale from 0 to 14. A test kit for measuring pH balance of your pool water is available from your local pool supply store; see Table 5.

Table 5. pH Chart

Strongly Acid			Neutral					Strongly Alkaline						
0	1	2	3	4	5	6	7	8	9	10	11	12	13	14

Muriatic Acid has a pH of about 0. Pure water is 7 (neutral). Weak Lye solution have a pH of 13-14.

RULE: 7.4 to 7.6 is a desirable pH range. It is essential to maintain correct pH, see Table 6.

If pH becomes too high (over alkaline), it has these effects:

1. Greatly lowers the ability of chlorine to destroy bacteria and algae.
2. Water becomes cloudy.
3. There is more danger of scale formation on the plaster or in the heat exchanger.
4. Filter elements may become blocked.

If pH is too low (over acid) the following conditions may occur:

1. Excessive eye burn or skin irritation.
2. Etching of the plaster.
3. Corrosion of metal fixtures in the filtration and recirculation system, which may create brown, blue, green, or sometimes almost black stains on the plaster.
4. Corrosion of copper in the heater, which may cause leaks.
5. If you have a sand and gravel filter, the alum used as a filter aid may dissolve and pass through the filter.

CAUTION: Do not test for pH when the chlorine residual is 3.0 ppm or higher, or bromine residual is 6.0 ppm or higher. See your local pool supply store for help in properly balancing your water chemistry.

RULE: Chemicals that are acid lower pH. Chemicals that are alkaline raise pH.

Table 6. pH Control Chart

6.8	7.0	7.2	7.4	7.6	7.8	8.0	8.2	8.4
Add Soda, Ash or Sodium Bicarbonate		Marginal	Ideal	Marginal	Add Acid			

ALKALINITY High - Low:

"Total alkalinity" is a measurement of the total amount of alkaline chemicals in the water, and control pH to a great degree. (It is not the same as pH which refers merely to the relative alkalinity/acidity balance.) Your pool water's total alkalinity should be 100 - 140 ppm to permit easier pH control.

A total alkalinity test is simple to perform with a reliable test kit. You will need to test about once a week and make proper adjustments until alkalinity is in the proper range. Then, test only once every month or so to be sure it is being maintained. See your local pool dealer for help in properly balancing the water chemistry.

Troubleshooting - General

<i>Possible Cause</i>	<i>Remedy</i>
Heater will not come on	
Automatic ignition system fails	Check if electrical connections are correct and securely fastened – If YES, call serviceperson.
Pump not running	Place pump in operation
Pump air locked	Check for leaks
Filter dirty	Clean filter
Pump strainer clogged	Clean strainer
Defective wiring or connection	Repair or replace wires
Defective pressure switch	Replace switch
Defective gas controls	Call serviceperson
On-Off switch in "OFF" position	Turn switch to "ON"
Heater Short Cycling (Rapid On and Off Operation)	
Insufficient water flow	Clean filter and pump strainer
Defective wiring	Repair or replace wiring
Defective flow valve or out of adjustment	Call serviceperson
Defective hi-limit and/or thermostat	Call serviceperson
Heater Makes Knocking Noises, Make sure all valves on system are open	
Heater operating after pump has shut off	Shut off gas supply and call serviceperson
Heater exchanger scaled	Shut off gas supply and call serviceperson

SERVICE CHECKS—IGNITION MODULE

Service Checks	
Symptom	Cause/Cure
1. Dead	A. Miswired B. Transformer bad C. Fuse/Circuit breaker bad D. Bad control
2. Thermostat on—no ignition	A. Miswired B. Bad thermostat no voltage at terminal
3. Valve on, no ignition	A. Defective ignitor B. Miswired C. Bad control (check voltage at ignitor)
4. Ignitor on, no valve action	A. Valve coil open B. Open valve wire C. Bad control (check voltage)
5. Flame okay during Try For Ignition (TFI), no flame sense (after TFI)	A. Bad flame sensor B. Bad wires C. Poor ground at burner D. Poor flame (check flame current)

MINIMAX NT STANDARD HEATER *(Non-ASME Shown)*

(Dual Voltage w/6800 Controller)

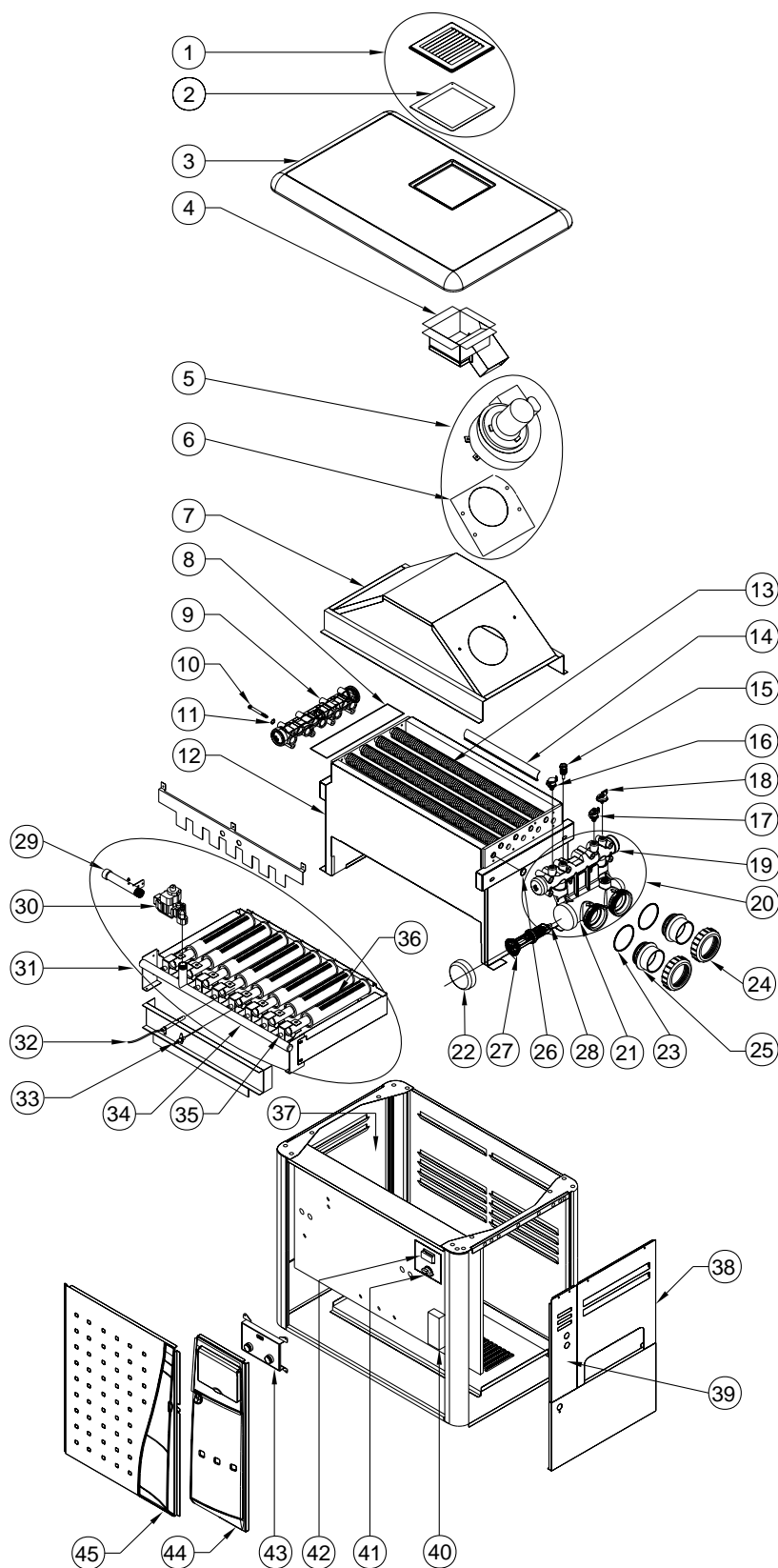

MiniMax NT STD w/6800 Controller Replacement Parts						
Item	Description	Quantity	200	250	300	400
1	Exhaust Grill w/Gasket	1	472352			
2	Gasket, Exhaust Grill	1	471701			
3	Top Cover w/Posts	1	472353	472354	472355	472356
4	Exhaust Assembly	1	472373	472376	472373	
5	Blower w/Gasket	1	472361	472362		472374
6	Gasket, Blower	1	471610			
7	Flue Collector	1	472008	472007	472006	472005
8	Insulation, Header/Hi-Limit	1	472270			
9	Return Header Assembly	1	471991			
10	Bolt, Heat Exchanger	16	471622			
11	Washer, Heat Exchanger	16	072184			
12	Fire Box Assembly	1	471904	471835	471922	472332
13	Heat Exchanger w/Headers	1	471910	471785	471928	471838
	Heat Exchanger w/o Headers	1	471933	471934	471935	471936
14	Baffle, Heat Exchanger	8 / 16 (200,250,300/400)	471642	471641	471896	471640
15	Thermistor Probe	1	471566			
16	Hi-Limit Thermostat - 115° F.	1	471587			
17	Hi-Limit Thermostat - 150° F.	1	471694			
18	Water Pressure Switch	1	472125			
19	In/Out Top Sub-Header Assembly	1	472363			
20	In/Out Main Header Assembly	1	471992			
21	In/Out Bottom Sub-Header	1	472364			
22	Cap, In/Out Bottom Sub-Header	1	471420			
23	O-Ring, Adapter	2	274494			
24	Adapter, Bulkhead Ring	2	274440			
25	Adapter, Bulkhead, 2"	2	471441			
26	Gasket, Fin Tube, Seal	18	070951			
27	Flow Valve Assembly	1	471750			
28	Power Element, Flow Valve	1	471625			
29	Sub-Gas Manifold w/Plug	1	472365			
30	Gas Valve - Natural Gas	1	471601			
	Gas Valve - Propane		471671			
31	Burner Tray Assembly, Natural Gas	1	472042	472037	472033	472028
	Burner Tray Assembly, Propane		471907	471913	471925	471931
32	Igniter	1	471602			
33	Flame Sensor	1	471603			
34	Gas Manifold w/Orifices, Natural, 0-2000'	1	472023	472022	472021	472020
	Gas Manifold w/Orifices, Propane, 0-2000'		472027	472026	472025	472024
35	Orifices, Natural, 0-2000'	4 / 5 / 6 / 8 (200/250/300/400)	073727			
	Orifices, Propane, 0-2000'		073728			
36	Burner	2 / 3 / 4 / 6 (200/250/300/400)	070230			
	Burner w/Bracket	2	471970			
37	Jacket, Upper Panel, Left	1	471575			
38	Jacket, Upper Panel, Right	1	471576			
39	Jacket, Upper Sub-Plate	2	471767			
40	Junction Box Assembly	1	472015			
41	Air Pressure Switch, 0-4000'	1	472311	472313	472314	472315
42	Module, Ignition Control	1	472080			
43	Temperature Controller Assembly	1	472086			
44	Right Door Assembly with Controller	1	472087			
	Right Door Assembly W/O Controller	1	472372			
45	Left Door Assembly	1	471900	472318	471918	471726
NA	Thermal Cut-off (Not Shown)	1	075173			
NA	Transformer, 40 VA (Not Shown)	1	471571			
NA	Wire Harness Assembly (Not Shown)	1	472375			
NA	Indoor Vent Adaptor (Not Shown)	1	460506(4") ; 460507(5")			
NA	Non-Combustible Base (Not Shown)	1	471390	471391	471393	471394

Note: Parts for ASME and high altitude are not listed above, please contact our Customer Service Department for details.



Because *reliability* matters most

MiniMax[®] NT Heaters Limited Warranty

Your MiniMax[®] NT pool heater is another quality product from Pentair Pool Products, Inc. and is backed by the following warranty.

1. The following parts are warranted for 5 years from date of purchase:

The MiniMax NT cabinet and combustion chamber, the main burners and burner manifold, the inlet/outlet header and the return header. This warranty does not cover rusting or corrosion on cabinets or burners that does not affect the heater's operation.

2. The following parts are covered for 2 years from date of purchase:

The automatic flow control valve, all controls, heat exchanger, pilot generator and the pilot assembly.

This warranty only applies to the original purchaser.

3. This warranty shall not apply to any units or parts which have been subject to accident, negligence, alteration, abuse, misapplication or misuse.

The above warranty applies only if the heater is installed and operated in complete compliance with the installation and operation manual provided with each unit. Copies of this manual are available by writing to Pentair Pool Products, Inc., at the address below.

Pentair Pool Products, Inc. assumes no liability except for the repair or replacements of parts as specified above. Ship defective parts or equipment along with serial number and purchase date, transportation prepaid to the address below. Purchaser shall be responsible for freight charges for return of merchandise to purchaser. Some states do not allow exclusion or limitation of incidental or consequential damages so the above may not apply to you.

This warranty gives you specific legal rights, and you may also have other rights which vary from state to state.

HEATER SERIAL NUMBER

(Please Fill In)

Pentair Pool Products, Inc.

1620 Hawkins Ave., Sanford, NC 27330 • (919) 774-4151
10951 W. Los Angeles Ave., Moorpark, CA 93021 • (805) 523-2400