

STA-RITE®

SERIES "ABG"

SWIMMING POOL PUMP

O W N E R ' S M A N U A L

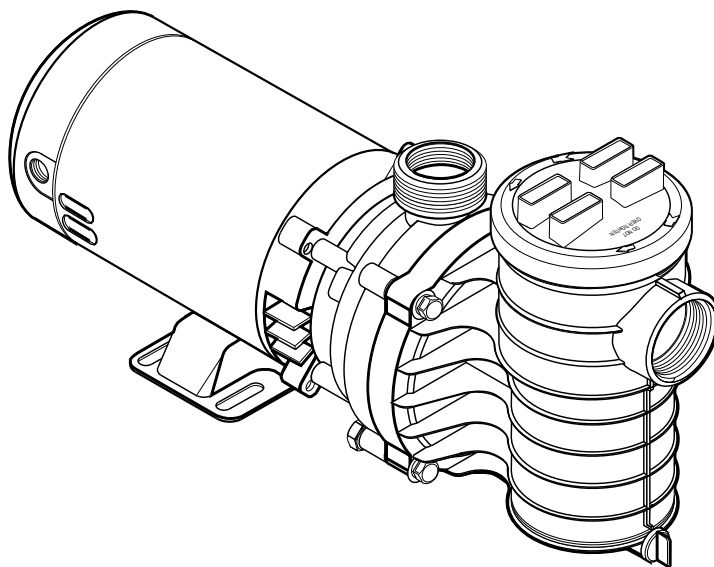

INSTALLATION, OPERATION & PARTS

This manual should be furnished to the end user of this pump; its use will reduce service calls and chance of injury and will lengthen pump life.

Sta-Rite Pool/Spa Group

293 Wright Street, Delavan, WI 53115

North America: 800-752-0183, FAX 800-582-2217

International: 262-728-5551, FAX: 262-728-4461, TELEX: ITT 4970245

www.sta-ritepool.com

Union City, TN • Delavan, WI • Mississauga, Ont. • Murrieta, CA

Printed in U.S.A. © 2003, Sta-Rite Industries, Inc.

S486 (Rev. 2/6/03)

STA-RITE "ABG" SERIES SWIMMING POOL PUMP

To avoid unneeded service calls, prevent possible injuries, and get the most out of your pump, READ THIS MANUAL CAREFULLY!

The Sta-Rite 'ABG' Series Above Ground Pool Pump:

- Is designed to circulate water in above ground swimming pools (not for use in spas or inground pools).
- Is an excellent performer; durable, reliable.

Table of Contents

Safety Instructions	2-3
Installation.....	3-4
Electrical.....	5
Operation	6
Storage/Winterizing	7
Pump Service.....	8
Troubleshooting Guide	9
Repair Parts List.....	10-11
Warranty.....	12

READ AND FOLLOW SAFETY INSTRUCTIONS!

▲ This is the safety alert symbol. When you see this symbol on your system or in this manual, look for one of the following signal words and be alert to the potential for personal injury.

▲ DANGER warns about hazards that **will** cause death, serious personal injury, or major property damage if ignored.

▲ WARNING warns about hazards that **can** cause death, serious personal injury, or major property damage if ignored.

▲ CAUTION warns about hazards that **will** or **can** cause minor personal injury or property damage if ignored.

NOTICE indicates special instructions not related to hazards.

Carefully read and follow all safety instructions in this manual and on equipment. Keep safety labels in good condition; replace if missing or damaged.

▲ WARNING **Hazardous pressure** **Incorrectly installed or tested equipment may fail, causing severe injury or property damage.**
Read and follow instructions in owner's manual when installing and operating equipment. Have a trained pool professional perform all pressure tests.

IMPORTANT SAFETY INSTRUCTIONS

Always follow basic safety precautions with this equipment, including the following.

▲ WARNING To reduce the risk of injury, do not permit children to use this product unless they are closely supervised at all times.

SAVE THESE INSTRUCTIONS

1. Do not connect system to a high pressure or city water system.
2. Use equipment only in a pool installation.
3. Trapped air in system can cause explosion. BE SURE all air is out of system before operating or testing equipment.

Tighten Sta-Rite trap lids to hand tight only.

Water pressure must be less than 25 PSI (7.5 kg/cm²).

Water Temperature must be less than 104° F (40° C).

▲WARNING **Fire and burn hazard.** Modern motors run at high temperatures. To reduce the risk of fire, do not allow leaves, debris, or foreign matter to collect around the pump motor. To avoid burns when handling the motor, let it cool for 20 minutes before trying to work on it. An automatic internal cutoff switch protects the motor from heat damage during operation.

INSTALLATION

For ease of pump/motor removal, install pipe unions on the suction and discharge pipes close to pump.

Pump mount must:

Be located away from corrosive or flammable liquids.

Have enough ventilation to maintain air temperature at less than the maximum ambient temperature rating (Max. Amb.) listed on the motor model plate. If this pump is installed in an enclosure/pump house, the enclosure must have adequate ventilation and air circulation to keep the temperature in the enclosure at or below the motor's rated ambient temperature whenever the pump is running.

Be solid - Level - Rigid - Vibration free. (To reduce vibration and pipe stress, bolt pump to mount.)

Allow pump suction inlet height to be at or below water level in pool.

Allow use of short, direct suction pipe (To reduce friction losses).

Allow for gate valves in suction and discharge piping.

Have adequate floor drainage to prevent flooding.

Be protected from flooding.

Allow adequate access for servicing pump and piping.

NOTICE: Use Teflon tape or Plasto-Joint Stik¹ for making all threaded connections to the pump. Do not use pipe dope; pipe dope will cause stress cracking in the pump.

NOTICE: Pump suction and discharge connections have molded in thread stops. DO NOT try to screw pipe in beyond these stops. Tighten the pump/trap fittings only as much as it is required to insure a tight connection (1-1/2 turns past hand tight is sufficient). Overtightening may damage the pump trap. Use care when using teflon tape as friction is reduced considerably; do not overtighten connections or damage may occur.

¹Lake Chemical Co., Chicago, Illinois

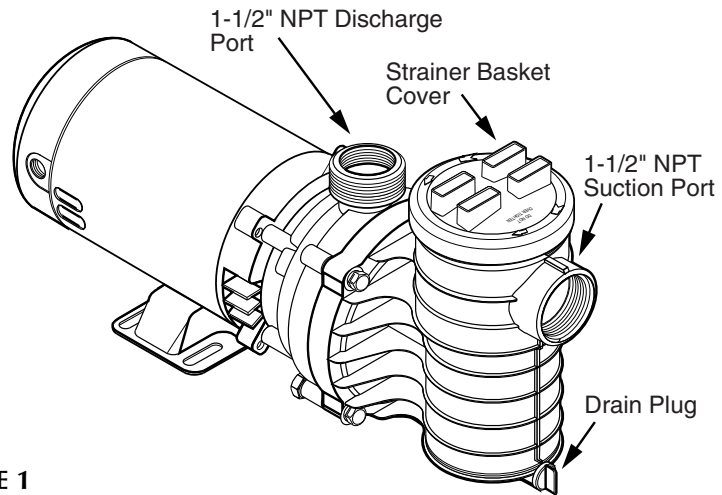

FIGURE 1

Teflon Taping Instructions:

Use only new or clean PVC pipe fittings.

Wrap male pipe threads with one to two layers of Teflon tape. Cover entire threaded portion of pipe.

Do not overtighten or tighten past thread stop in pump port!

If leaks occur, remove pipe, clean off old tape, rewrap with one to two additional layers of tape and remake the connection.

NOTICE: Support all piping connected with pump!

Piping:

To avoid strains on the pump, support both suction and discharge pipes or hoses independently. Place these supports near the pump.

To avoid airlocking, slope suction pipe slightly upward toward the pump.

NOTICE: To prevent flooding when removing pump for service, all flooded suction systems **must** have gate valves in suction and discharge pipes.

Union available for pump discharge port (Sta-Rite part number WC198-105). Use as follows for leak-free connection to pump:

1. O-Ring and sealing surfaces must be clean.
2. Assemble handtight only! (NO WRENCHES!)
3. NO pipe compound or teflon tape on union.
4. Bond pipe to union with PVC cement.

Use PVC cement only in a well ventilated area away from flame;

FOLLOW MANUFACTURER'S INSTRUCTIONS!

Fittings:

Fittings restrict flow; for best efficiency use fewest possible fittings.

Avoid fittings which could cause an air trap.

NOTICE: Determine circuit breaker rating from Table I. Determine correct outlet required from illustration below.

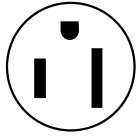

“ABG” Models with -2A2, -2A4, and -3A4 suffix use 15-amp straight outlet.

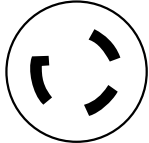

“ABG” Models with -2A1 suffix use 20-amp twist-lock outlet.

FIGURE 2 - Plug Configurations



ELECTRICAL

- ⚠ To avoid dangerous or fatal electrical shock, turn OFF power to motor before working on electrical connections.**
- ⚠ Ground Fault Circuit Interrupter (GFCI) tripping indicates an electrical problem. If GFCI trips and will not reset, have a qualified electrician inspect and repair electrical system.**
- ⚠ Exactly match supply voltage to nameplate voltage! Incorrect voltage can cause fire or seriously damage motor and voids warranty. If in doubt consult a licensed electrician.**
- ⚠ Plug cord of pump directly into a GFCI protected receptacle.**

Voltage:

Voltage at motor must be not more than 10% above or below motor nameplate rated voltage or motor may overheat, causing overload tripping and reduced component life. If voltage is less than 90% or more than 110% of rated voltage when motor is running at full load, consult power company.

Wiring:

Do not alter cord or plug on cord-connected units. Plug in to a GFCI protected, grounded outlet only. If plug and outlet do not match, consult a licensed electrician.

Table I, gives correct circuit breaker sizes for the pump alone. If other lights or appliances are also on the same circuit, be sure to add their amp loads to pump amp load before figuring circuit breaker sizes. (If unsure how to do this or if this is confusing, consult a licensed electrician.) Use the load circuit breaker as the master on-off switch.

Install a Ground Fault Circuit Interrupter (GFCI) in circuit; it will sense a short-circuit to ground and disconnect power before it becomes dangerous to pool users. For size of GFCI required and test procedures for GFCI, see manufacturer’s instruction.

In case of power outage, check GFCI for tripping (which will prevent normal pump operation). Reset if necessary.

NOTICE: If you do not use conduit when wiring motor, **be sure** to seal wire opening on end of motor to prevent dirt, bugs, etc., from entering.

⚠ CAUTION Values given in table below are for **PUMP MOTOR ONLY**. If additional accessories are installed on pump motor circuit (heater, blower, etc.), include their amperage draw when figuring wire and circuit breaker sizes.

TABLE I - RECOMMENDED FUSING DATA

Model Number	Motor H.P.	Branch Fuse Rating Amps*	Max Load Amps	Voltage/Hz/Phase
1-Speed				
ABG4C	1/2	15	8.0	115/60/1
ABG4D, ABG4DL, ABG4D7, ABG4D7L	3/4	15	9.0	115/60/1
ABGS4D, ABGS4D7	3/4	15	8.0	115/60/1
ABG4DC, ABG4D7C	3/4	15	9.4	115/60/1
ABG4E, ABG4EL, ABG4E7L, ABG4E7	1	15	12.0	115/60/1
ABGS4E, ABGS4E7	1	15	9.6	115/60/1
ABG4EC, ABG4E7C	1	15	11.9	115/60/1
ABG4F, ABG4F7	1-1/2	20	16.0	115/60/1
ABGS4FC, ABGS4F7C	1-1/2	15	11.9	115/60/1
ABGS4F, ABGS4F7	1-1/2	15	12.0	115/60/1
2-Speed				
ABG4YE, ABG4YE7	1	15	11.7/3.39	115/60/1
ABG4YF, ABG4YF7	1-1/2	25	16.6/3.6	115/60/1

*Time delay fuses are recommended instead of standard fuses in any motor circuit.



OPERATION

⚠ NEVER run pump dry! Running pump dry may damage seals, causing leakage and flooding! Fill pump with water before starting motor.

⚠ Before removing trap cover:

1. **STOP PUMP** before proceeding.
2. **CLOSE GATE VALVES** in suction and discharge pipes.
3. **RELEASE ALL PRESSURE** from pump and piping system.

⚠ WARNING **Fire and burn hazard.** Modern motors run at high temperatures. To reduce the risk of fire, do not allow leaves, debris, or foreign matter to collect around the pump motor. To avoid burns when handling the motor, let it cool for 20 minutes before trying to work on it. An automatic internal cutoff switch protects the motor from heat damage during operation.



⚠ Do not block pump suction! To do so with body may cause severe or fatal injury. Small children using pool must ALWAYS have close adult supervision!

NOTICE: Do not block pool return. To do so may flood area causing damage to equipment and water damage to surrounding area.

Priming Pump:

Open valves before starting system.

Release all pressure from filter, pump, and piping system; see the filter owner's manual.

In a flooded suction system (water source higher than pump), pump will prime itself when suction and discharge valves are opened.

Pool Water:

Keep water level at least two inches above bottom of skimmer opening when system is not in use. Failure to do so can allow air to enter system, causing pump to lose its prime.

Keep pool water "balanced". Maintain the water pH between 7.2 and 7.6.

⚠ Do not use or allow the use of the pool by anyone using alcohol or drugs. The effects of hot water, alcohol and/or drugs can cause dizziness and falling, loss of consciousness, or heart attack.

Storage/Winterizing:

⚠ WARNING **Explosion hazard. Purging the system with compressed air can cause components to explode, with risk of severe injury or death to anyone nearby.** Use only a low pressure (below 5 PSI), high volume blower when air purging the pump, filter, or piping.

⚠ To prevent damage to components from fumes, store chemicals away from pump. If possible, store chemicals in another room.

NOTICE: Drain pump! Allowing pump to freeze will damage pump and void warranty!

NOTICE: Do not use anti-freeze solutions (except propylene glycol) in your pool system. Propylene glycol is non-toxic and will not damage plastic system components; other anti-freezes are highly toxic and may damage plastic components in the system. Propylene glycol is widely used as antifreeze in recreational vehicles.

Drain all water from pump and piping when expecting freezing temperatures or when storing pump for a long time (see instructions below).

Keep motor dry and covered during storage.

To avoid condensation/corrosion problems, **do not** cover or wrap pump with plastic.

For outdoor/unprotected installations:

1. Pump down water level below all inlets to pool.
2. Enclose entire system in a weatherproof enclosure.
3. To avoid condensation/corrosion damage, allow ventilation; **do not** wrap system in plastic.
4. Use a 40% propylene glycol/60% water solution to protect pump to -50°F.
5. Follow pool manufacturer's directions for storage of pool.



Draining Pump:

⚠ WARNING To avoid dangerous or fatal electrical shock hazard, turn OFF power to motor before draining pump.

1. Close all valves on suction and return piping.
2. Remove drain plug in bottom of trap body.
3. Drain all piping and storage tanks exposed to freezing temperatures.
4. Be sure no airlocks are holding water in the system.
5. To prevent pump from freezing, remove trap cover and drain the tank body through the drain plug (Key No. 12, Page 10 and Key No. 18, Page 11). Clean pump thoroughly. Replace trap cover.
6. Before restarting, replace all plugs and make sure all pipe connections are tightly sealed.

Startup For Winterized Equipment:

1. Remove any temporary weather protection placed around system for shutdown.
2. Follow filter manufacturer's instructions for reactivation of the filter.
3. Inspect all electrical wiring for damage or deterioration over the shutdown period. Have a qualified serviceman repair wiring as needed.
4. Inspect and tighten all watertight connections.
5. Open all valves in suction and return piping.
6. Remove any winterizing plugs in piping system.
7. Drain all antifreeze from system.
8. Close all drain valves and replace all drain plugs in piping system.
9. Prime pump according to instructions on Page 6.
10. Refill pool to proper water level.

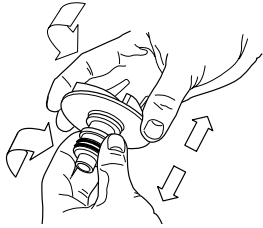

Figure 3

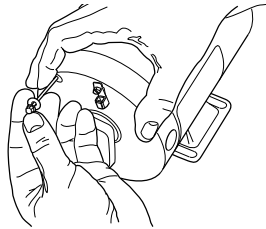

Figure 4

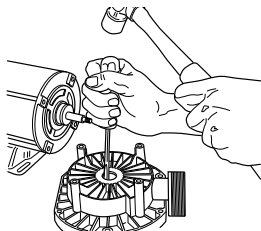

Figure 5

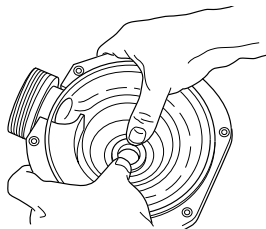

Figure 6

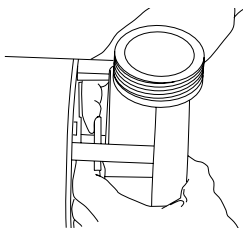

Figure 7

PUMP SERVICE

Pump should only be serviced by qualified personnel.
Be sure to prime pump (Page 7) before restarting.

⚠ Before removing trap cover:

1. STOP PUMP before proceeding.
2. CLOSE GATE VALVES in suction and discharge pipes.
3. RELEASE ALL PRESSURE from pump and piping system.

⚠ WARNING To avoid dangerous or fatal electrical shock hazard, turn OFF power to motor before working on pump or motor.

No lubrication or regular maintenance is needed beyond reasonable care and periodic cleaning.

If shaft seal is worn or damaged, repair as follows:

Removing Old Seal:

1. Disconnect power to pump motor.
2. Drain pump; disconnect unions to allow access to pump.
3. Remove four bolts holding trap body to seal plate; remove trap body.
4. Remove shaft cover or motor canopy; using screwdriver in slot on motor end of shaft or wrench on flats of shaft extension, hold pump shaft and unscrew impeller from shaft (turn counterclockwise). Rotating half of seal will come off with impeller.
5. Carefully remove rotating part of seal from impeller sleeve by pulling and turning on sealing washer and spring (Figure 3). Do not damage impeller surface where drive ring seats and seals.
6. Carefully remove four motor throughbolts from seal plate (Figure 4); remove seal plate and use a screwdriver to tap ceramic seat out from the rear (Figure 5). Do not damage seal cavity in seal plate.
7. Clean cavity from which seal was removed and clean motor shaft.

Installing New Seal:

1. Ceramic seat must be clean and free of dirt, grease, dust, etc. Wet rubber cup gasket of ceramic seat with **small** amount of water; press into cavity firmly and squarely with finger pressure (Figure 6).
2. If ceramic seat will not locate properly, remove it, place **face up** on bench, and reclean cavity. Ceramic seat should now locate.
3. Seal must be free of dirt, grease, grit, scratches or chips; be sure impeller sleeve is clean. Slide seal assembly, rubber drive ring first, onto impeller sleeve until drive ring bottoms on impeller back shroud.
4. Slip slinger over shaft; remount seal plate. Torque throughbolts to 25 inch-lbs. (29 cm-kg).
5. Screw impeller onto shaft until it seats against shaft shoulder. Work slinger over end of impeller sleeve so it rides on sleeve (Figure 7).
6. Install wear ring on back of volute. **NOTICE:** Teeth on wear ring interlock with ribs on trap body.
7. Remount trap body.
8. Reconnect unions; tighten **hand tight only**.

TROUBLESHOOTING GUIDE

 **Read and understand safety and operating instructions in this manual before doing any work on pump!**

 **Only qualified personnel should electrically test pump motor!**

FAILURE TO PUMP; REDUCED CAPACITY OR DISCHARGE PRESSURE

Suction leaks/lost prime:

1. Pump must be primed; make sure that pump volute and trap are full of water. See priming instructions, Page 6.
2. Make sure there are no leaks in suction piping.
3. Make sure suction pipe inlet is well below the water level to prevent pump from sucking air.
4. Suction lift of 1 to 2 feet (.3-.6M) will reduce performance. Suction lift of more than 2 feet (.6M) will prevent pumping and cause pump to lose prime. In either case, move pump closer (vertically) to water source. Make sure suction pipe is large enough.

Clogged pipe/trap/impeller, worn impeller:

1. Make sure suction trap is not clogged; if it is, clean trap and strainer.
2. Make sure impeller is not clogged (follow instructions under "Removing Old Seal", Page 8; check impeller for clogging; follow instructions under "Installing New Seal", above, for reassembly).
3. Impeller and diffuser may be worn. If so, order replacement parts from Repair Parts List, Pages 10 and 11.

Inadequate Circulation or Jet Action:

1. Check for blocked fittings. Blocked fittings will cause poor flow and poor jet action.
2. Check trap basket; if plugged, turn pump off and clean basket. Check and clean skimmer basket.
3. Check that gate valves are fully open.
4. Suction/discharge piping is too small.
5. Check and clean pool filter.
6. Check for clogged pipe/trap/impeller, Page 8.
7. Consult dealer/installer or service representative.

Circuit Breaker In Home Panel Trips Repeatedly:

1. Breaker must be of adequate capacity.
2. For GFCI breaker, test according to GFCI manufacturer's instructions.
3. Be sure no other lights and appliances are on circuit.
4. Consult dealer/installer or service representative.
5. Voltage too high or too low. See "Voltage", Page 5.

Electrical:

1. Pump may be running too slowly; check voltage at motor terminals and at meter while pump is running. If low, see wiring instructions or consult power company. Check for loose connections.
2. Pump may be too hot.
 - A. Check line voltage; if less than 90% or more than 110% of rated voltage consult a licensed electrician.
 - B. Increase ventilation.
 - C. Reduce ambient temperature.
 - D. Tighten any loose wiring connections.
3. Motor internal thermal overload protector is open. Motor runs too hot. Turn power to motor off. Check for proper voltage. Check for proper impeller or impeller rubbing.
4. Consult dealer/installer or service representative.

Mechanical Troubles and Noise:

1. If suction and discharge piping are not adequately supported, pump assembly will be strained. See "Installation", Page 3.
2. Do not mount pump on a wooden platform! Securely mount on concrete platform for quietest performance.
3. Air leak in suction line (bubbles in water returning to pool). Repair leak. Tighten trap lid.
4. Foreign matter (gravel, metal, etc.) in pump impeller. Disassemble pump, clean impeller, follow pump service instructions on Page 8 for reassembly.
5. Cavitation.
 - Improve suction conditions.
 - Increase pipe size.
 - Decrease number of fittings.
 - Increase discharge pressure.
 - Reducer flow by throttling discharge gate valve.

REPAIR PARTS LIST

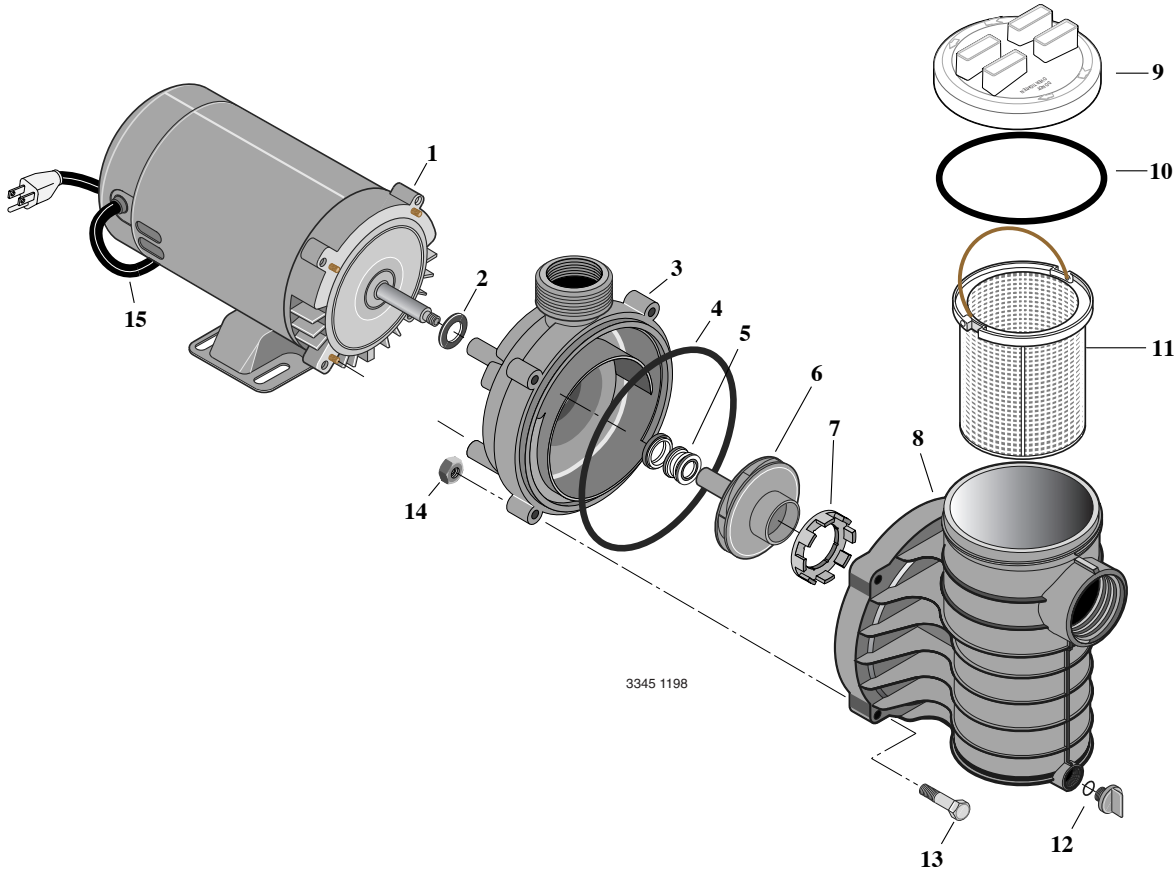

Parts are common to all models listed except as noted:
Key Nos. 1, Motor; 6, Impeller; and 17 Cord are listed below.

Key No.	Part Description	Qty.	Part No.
1	Motor	1	Chart at Right
2	Slinger	1	C69-2
3	Seal Plate	1	17500-0001
4	Seal Plate O-Ring	1	35505-1438
5	Shaft Seal	1	U109-358SS
6	Impeller	1	Chart at Right
7	Floating Wear Ring	1	17500-0004
8	Trap Body	1	17500-0002
9	Trap Lid	1	17500-0003
10	Trap Lid O-Ring	1	35505-1437
11	Trap Basket	1	17350-0100
12	Drain Plug	1	U178-920P
13	Hex Head Bolt, 1/4-20x1-3/4"	4	30787-0005
14	Hex Nut	4	35402-0071
15	Cord	1	Chart at Right
	• Hardware Kit* (2 Bolts, 2 Washers)	1	17290-0001
	• Nameplate	1	U33-155
	• Warning Tag	1	61002-0013
	• Caution Tag	1	C63-12
	• Decal - "GFCI Required"	1	U27-558

• Not illustrated.
* Included with top discharge pumps only.

Model No.	HP	Motor No. Key No. 1	Impeller No. Key No. 6	Cord No. Key No. 17
115 Volt/1-Speed, Top Discharge				
ABG4C-3A4	1/2	62003-2034	17301-0114	31953-0116
ABG4DL-2A1	3/4	AS920DLL	17301-0113	31953-0101
ABG4D-2A4	3/4	AS920DLL	17301-0113	31953-0116
ABGS4D-3A4	3/4	62003-2035	17301-0114	31953-0116
ABG4EL-2A1	1	AS920ELL	17301-0112	31953-0101
ABG4EL-2A2	1	AS920ELL	17301-0112	U117-1117
ABG4E-2A4	1	AS920ELL	17301-0112	31953-0116
ABG4E-2A4SP	1	AS920ELL	17301-0112	31953-0116
ABGS4E-3A4	1	62003-2037	17301-0113	31953-0116
ABG4FL-2A1	1-1/2	AS920FLL	17301-0111	31953-0101
ABGS4F-2A4	1-1/2	62003-2031	17301-0112	31953-0116
115 Volt/1-Speed, Side Discharge				
ABG4D7L-2A1	3/4	AS920DLL	17301-0113	31953-0101
ABG4D7-2A4	3/4	AS920DLL	17301-0113	31953-0116
ABGS4D7-3A4	3/4	62003-2035	17301-0114	31953-0116
ABG4E7L-2A1	1	AS920ELL	17301-0112	31953-0101
ABG4E7L-2A2	1	AS920ELL	17301-0112	U117-1117
ABG4E7-2A4	1	AS920ELL	17301-0112	31953-0116
ABG4E7-2A4SP	1	AS920ELL	17301-0116	31953-0116
ABG4E7-2A4SPH	1	AS920ELL	17301-0113	31953-0116
ABGS4E7-3A4	1	62003-2037	17301-0113	31953-0116
ABG4F7L-2A1	1-1/2	AS920FLL	17301-0011	31953-0101
ABGS4F7-2A4	1-1/2	62003-2031	17301-0112	31953-0116
115 Volt/2-Speed, Top Discharge				
ABG4YE-2A4	1	62003-2021	17301-0112	31953-0116
ABG4YF-A2	1-1/2	62003-2032	17301-0111	U117-1117
115 Volt/2-Speed, Side Discharge				
ABG4YE7-2A4	1	62003-2021	17301-0112	31953-0116
ABG4YF7-A2	1-1/2	62003-2032	17301-0111	U117-1117

For complete suction trap order Pkg. 115.

REPAIR PARTS LIST

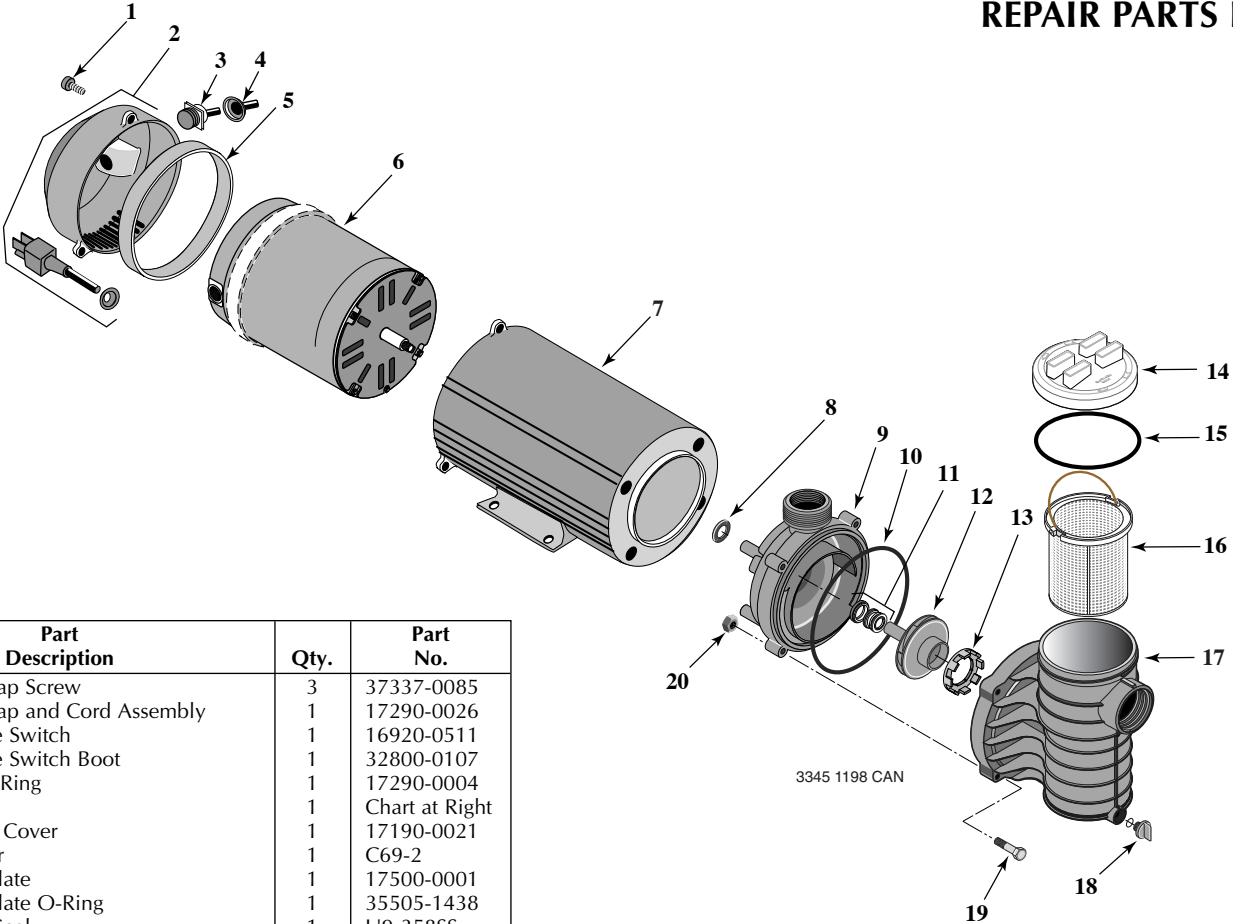

Key No.	Part Description	Qty.	Part No.
1	End Cap Screw	3	37337-0085
2	End Cap and Cord Assembly	1	17290-0026
3	Toggle Switch	1	16920-0511
4	Toggle Switch Boot	1	32800-0107
5	Baffle Ring	1	17290-0004
6	Motor	1	Chart at Right
7	Motor Cover	1	17190-0021
8	Slinger	1	C69-2
9	Seal Plate	1	17500-0001
10	Seal Plate O-Ring	1	35505-1438
11	Shaft Seal	1	U9-358SS
12	Impeller	1	Chart at Right
13	Floating Wear Ring	1	17500-0004
14	Trap Lid	1	17500-0003
15	Trap Lid O-Ring	1	35505-1437
16	Trap Basket	1	17350-0100
17	Trap Body	1	17500-0002
18	Drain Plug with O-Ring	1	U178-920P
19	Hex Head Bolt, 1/4-20x1-3/4"	4	30787-0005
20	Hex Nut	4	35402-0071
	• Hardware Kit (2 Bolts, 2 Washers)	1	17290-0001
	• Nameplate	1	U33-155
	• Warning Tag	1	61002-0013
	• Caution Tag	1	C63-12
	• Decal - "GFCI Required"	1	U27-558

Parts are common to all models listed except as noted:
Key Nos. 6, Motor; and 12, Impeller are listed below.

Model No.	HP	Motor No. Key No. 6	Impeller No. Key No. 12
115 Volt, Top Discharge			
ABG4DC-2A3	3/4	AS901DL	17301-0113
ABG4EC-2A3	1	AS901EL	17301-0112
ABGS4FC-2A3	1-1/2	AS901SFL	17301-0111
115 Volt, Side Discharge			
ABG4D7C-2A3	3/4	AS901DL	17301-0113
ABG4E7C-2A3	1	AS901EL	17301-0112
ABGS4F7C-2A3	1-1/2	AS901SFL	17301-0111

• Not illustrated.

For complete suction trap order Pkg. 115.

STA-RITE LIMITED WARRANTY

Pumps, filters, skimmers, underwater lights (except bulbs), accessories and fittings manufactured by Sta-Rite are warranted to be free of defects in material and workmanship for one (1) year from date of installation.

Product specific warranties: **Year from date of installation**

<i>HRPB, DEPB, System 3, System 2 and Posi-Clear</i>	
Tanks	10 years
Internal filter components and valves	1 year
<i>Max-E-Therm - Pool/Spa Heaters</i>	
Heater Enclosure only (Upper RH & LH; lower enclosure; and control board enclosure)...	10 years
<i>Automatic Pool Cleaners including Hose</i>	2 years
<i>Cristal-Flo filters - Tanks</i>	
Valve and internal components.	1 year
<i>Posi-Flo II - Tanks</i>	
Elements	1 year
<i>PRC Cartridge -</i>	
Filter Tanks	5 years pro-rated (1st 2 years full)
Elements	1 year
<i>System 2 Above Ground Systems - Tanks</i>	
Pumps / Platform and Internals	1 year
<i>Pumps</i>	
When equipped with A.O. Smith 2-compartment motors (Does not include pumps sold as part of a systems package)	2 years
<i>Traps / In-Line Strainers</i>	1 year
<i>Vertical Commercial Filter - Tanks</i>	
Internals	1 year
<i>Horizontal Commercial Filter</i>	
Tanks	5 years (Years 6-9, Prorated declining 20%/year, Yr. 10 - 10%)
Internals	1 year

* Full warranty coverage is in effect for one year after installation. The pro-rated warranty covers the *tank only* during the 2nd through 10th year after installation. The amount covered decreases by 10% each year. (ie., 2nd year 90% covered, 3rd year 80% covered, etc.).

The foregoing warranties relate to the original consumer purchaser ("Purchaser") only. Sta-Rite shall have the option to repair or replace the defective product, at its sole discre-

tion. Purchasers must pay all labor and shipping charges necessary to replace the product covered by this warranty. Requests for warranty service must be made through the installing dealer. This warranty shall not apply to any product that has been subject to negligence, misapplication, improper installation or maintenance, or other circumstances which are not in Sta-Rite's direct control.

This warranty sets forth Sta-Rite's sole obligation and Purchaser's exclusive remedy for defective products.

STA-RITE SHALL NOT BE LIABLE FOR ANY CONSEQUENTIAL, INCIDENTAL OR CONTINGENT DAMAGES WHATSOEVER.

THE FOREGOING WARRANTIES ARE EXCLUSIVE AND IN LIEU OF ALL OTHER EXPRESS WARRANTIES. IMPLIED WARRANTIES, INCLUDING BUT NOT LIMITED TO THE IMPLIED WARRANTIES OF MERCHANTABILITY AND FITNESS FOR A PARTICULAR PURPOSE, SHALL NOT EXTEND BEYOND THE DURATION OF THE APPLICABLE EXPRESS WARRANTIES PROVIDED HEREIN.

Some states do not allow the exclusion or limitation of incidental or consequential damages or limitations on how long an implied warranty lasts, so the above limitations or exclusion may not apply to you. This warranty gives you specific legal rights and you may also have other rights which vary from state to state.

Supersedes all previous publications.

Sta-Rite Industries, Inc.,
293 Wright St., Delavan, WI 53115

▲ **Retain Warranty Certificate (upper portion) in a safe and convenient location for your records.**

DETACH HERE: Fill out bottom portion completely and mail within 10 days of purchase/installation to:

▼ **Sta-Rite, Attn: Warranty Dept., 293 Wright St., Delavan, WI 53115**



Warranty Registration Card

Name _____

Address _____

City _____ State _____ Zip _____

Purchase Date _____

Product Purchased _____

New installation Replacement

Type of Pool Inground Vinyl Fiberglass Gunite

Size of Pool _____

Years pool has been in service less than 1 1-3 3-5 5-10

Purchased from: _____

Company name _____

Address _____

City _____ State _____ Zip _____

Please send me more information on these other products from Sta-Rite.

- Pumps Filters Automatic Pool Cleaners
 Maintenance Equipment Test Strips
 Heaters