



 **Polaris Watermatic**

G1000 Feeder

IMPORTANT INFORMATION

TABLE OF CONTENTS

I. INTRODUCTION	3
II. INSTALLATION	3
III. EXPLODED PARTS DIAGRAM	10
IV. OPERATION	11
A. Product Description	11
B. Proper Levels	11
C. Start-up Operations	11
D. Filling the Feeder	11
E. Use of Extension Hoppers/Extension Bottles	11
V. MAINTENANCE	12
A. Clean Strainer Screen	12
B. Sanitizer in Hopper	12
C. Clean Measuring Cup	12
D. Annual Maintenance	12
E. Winterizing	12
VI. TROUBLESHOOTING	13
VII. WARRANTY	14

Important Safety Instructions

When installing and using this product, basic safety precautions should always be followed including the following:

1. READ AND FOLLOW ALL OF THE INSTRUCTIONS.
2. DANGER—To reduce risk of injury, do not permit children to use this product unless they are closely supervised at all times.
3. SAVE THESE INSTRUCTIONS.

I. INTRODUCTION

The Polaris Watermatic® G1000 Feeder is designed to monitor and maintain the sanitizer level in swimming pools and spas. This state-of-the-art automated chemical feeder delivers a measured amount of granular sanitizer into the pool or spa upon demand during the filtration cycle. The G1000 requires an electronic controller to become a complete system. It can be used with the Watermatic C300, C310, C560 or C660 controllers.

IMPORTANT

THE POLARIS WATERMATIC G1000 IS DESIGNED FOR AT, OR ABOVE WATER LEVEL INSTALLATION.

II. INSTALLATION

The Watermatic G1000 Feeder is designed to be installed near the filter equipment of the pool or spa. Figure 1 reflects a typical installation for a pool or spa. Refer to Figure 2 if the pool and spa are to utilize the same filter equipment system. Figure 3 shows an application where the sanitizer is introduced after the pool equipment. This

application requires a separate venturi kit (part #9-710) for installation.

The feeder should be mounted within eight feet of the filter pump and the return line. The controller must be mounted on a wall or panel within eight feet of the feeder and ten feet or more from the swimming pool or spa.

The system must be installed in accordance with applicable local plumbing codes and in a manner that does not constitute a cross connection with the potable water supply.

TOOLS AND MATERIALS REQUIRED

- Electric drill; 7/16" drill bit, 1/8" NPT Tap or 1/4" NPT Tap
- Utility knife
- Flat screwdriver
- Phillips screwdriver
- Crescent wrench
- Volt meter
- Teflon paste
- DPD test kit
- Electrical wire and connectors (local code)
- Fasteners to mount control

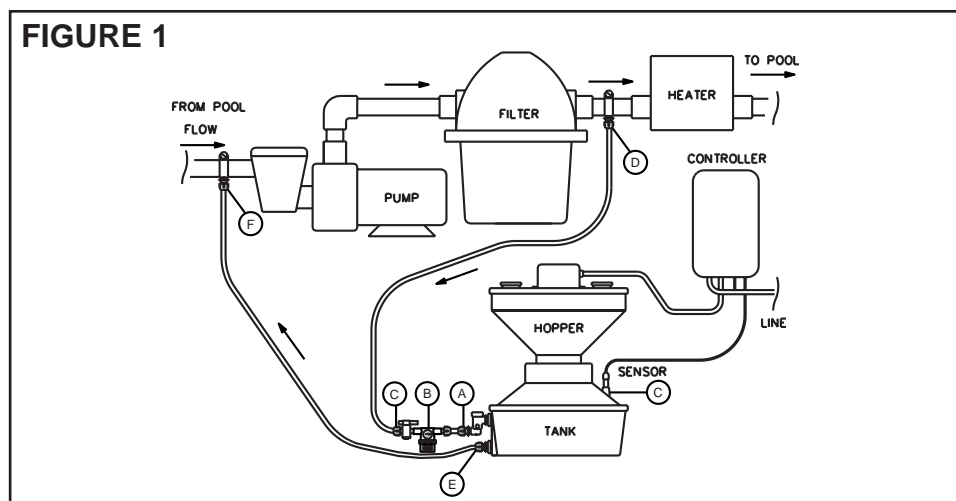

FIGURE 2

Pool and Spa
on Same Filter
System

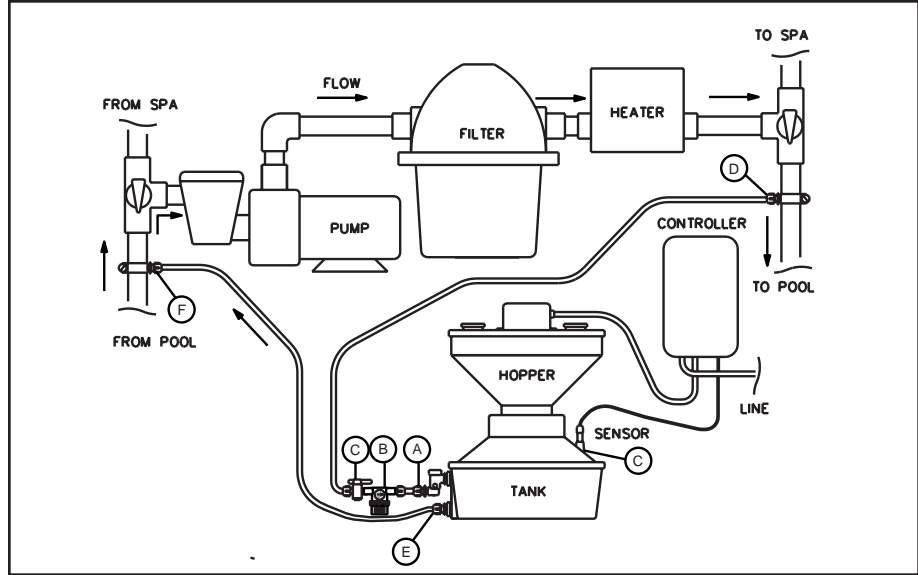

FIGURE 2A

Pool and Spa
on Same Filter
System

(Optional installation
method. See
Installation Tips
section for more
information.)

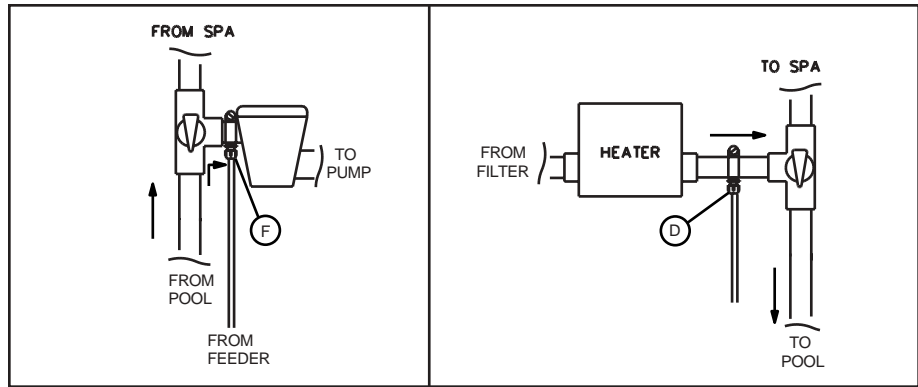
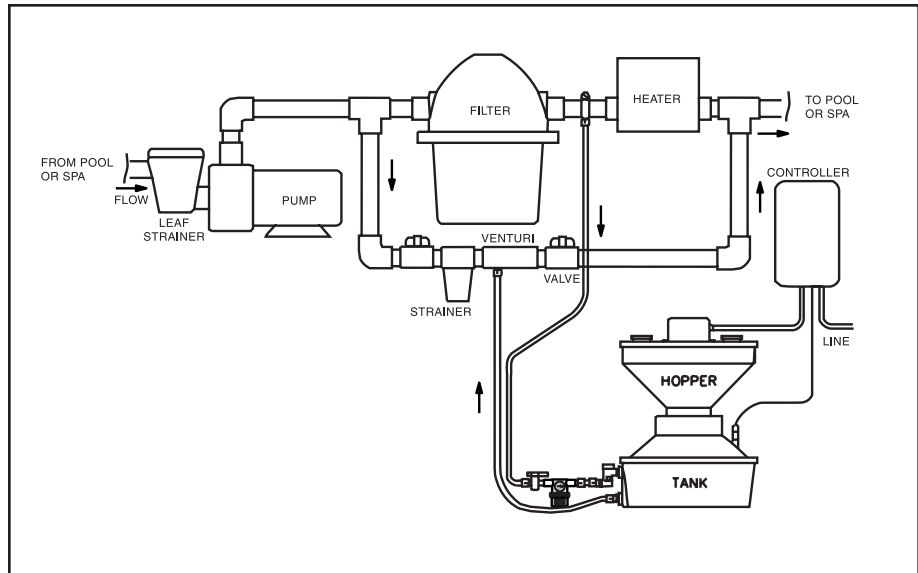

FIGURE 3

Installed with a
venturi



INSTALLATION TIPS

For Figure 2A

When the pool and spa are on the same filter system (Figure 2), an alternate installation method is available, shown in Figure 2A. In this application, the controller would be set in the spa mode to drop 1/4 or 1/2 oz. of sanitizer into the pool or spa, depending on the operating mode.

If the pool has heavy usage and exceeds a 35,000 gallons capacity, the installation method in Figure 2 is recommended.

Options for Extra Parts

Included in the parts bag are eight additional parts: (1) 1/8" check valve, (2) 1/8" x 3/8" compression fittings, (2) 1/4" x 3/8" compression fittings, (1) 1/8" on/off valve, (1) 1/4" x 1/8" reducer bushing, and (1) 1/4" female x 3/8" compression fitting.

- a) The on/off valve can be used with the reducer bushing and female compression fitting to isolate the suction side of the system.
- b) The 1/4" x 3/8" compression fittings can be used in place of the 1/8" x 3/8" compression fittings mentioned in the installation instructions, steps 8 and 9. This substitution allows the installer to use a 1/4" tap instead of a 1/8" tap.

ASSEMBLY AND INSTALLATION INSTRUCTIONS

STEP 1

Separate the hopper assembly from the tank. Set the hopper assembly aside.

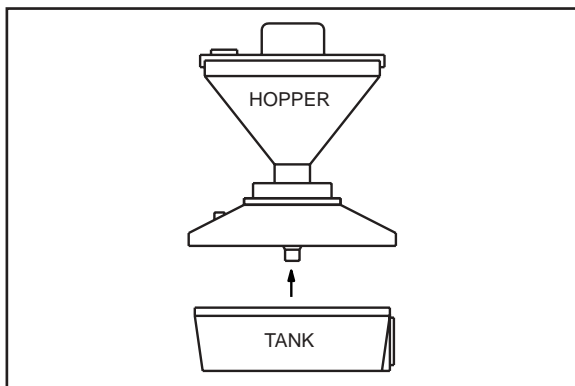

STEP 2

Make sure the float arm is in place and moves freely.

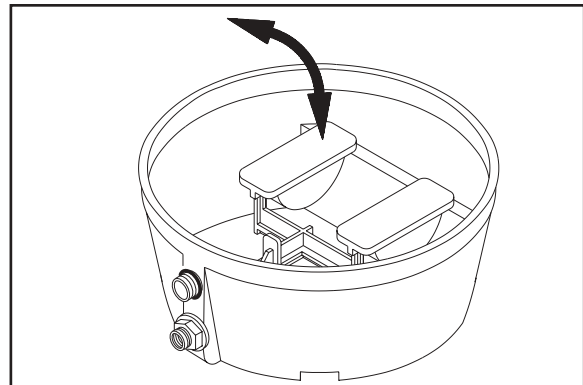

STEP 3 (Optional)

If the feeder is to be secured in position, install the three tank anchors to the bottom of the tank by hammering them into place. A small amount of PVC glue can be used to secure them.

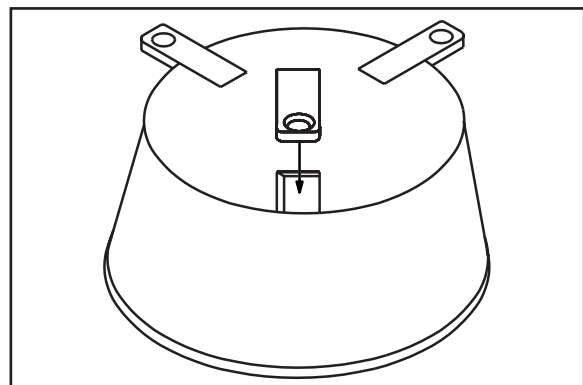

STEP 4

Apply teflon paste to the pipe threads of the Jaco fitting and install it hand tight into the lower orifice on the tank. Do not over tighten.

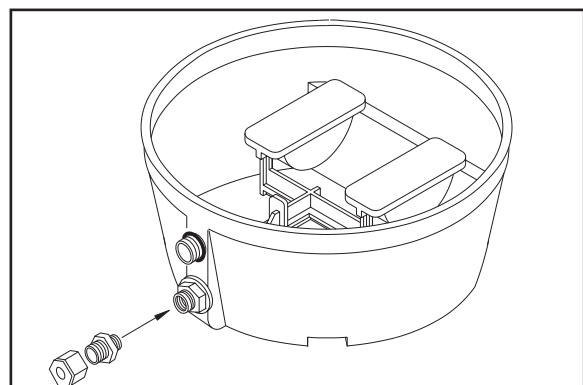

STEP 5

Apply teflon paste to the pipe threads on the check/flow valve and install it hand tight. The valve should be in the vertical position as shown. Do not over tighten.

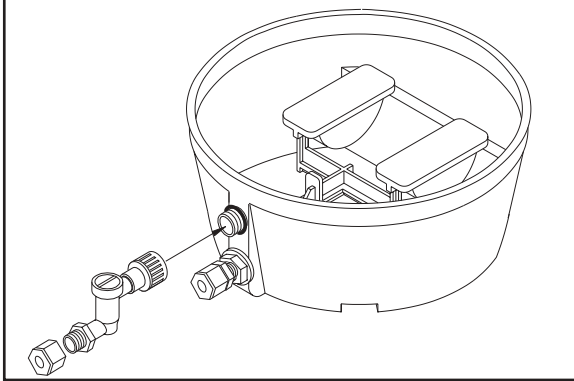

STEP 6

Attach the on/off valve to the strainer assembly and hand tighten. The arrow on the strainer should point toward the tank.

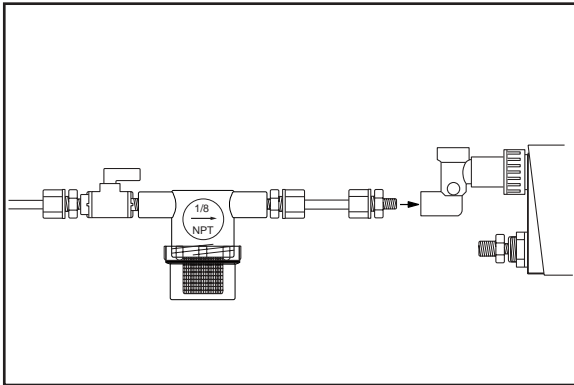

STEP 7

Be sure the power to the filter pump is off. Close any valves between the pool filter system and the pool. Place the tank on a level surface near the filter pump, no closer than six inches to the heater. Position it so it can be connected to both the suction side of the filter pump and the pressure side of the pump between the filter and the heater (see Figure 1). If the pool and spa are on same filter system refer to Figure 2 or 2A.

The feeder must be installed above water level. If necessary, mount the unit on a shelf.

STEP 8

There are two options for tapping into pipe:

Option A: As noted in the installation tips, 1/4" taps and fittings can be used. Drill and tap a 1/4" NPT hole in the pipe on the suction side of the pump (F on Figure 1), and also in the pipe on the pressure side of the pump (D, Figure 1). Avoid tapping into the top of the pipe.

Option B: Drill a 7/16" hole in the pipe on the suction side of the pump (F on Figure 1) and the pressure side of the pump (D on Figure 1). Avoid drilling into the top of the pipe.

STEP 9

Option A: If you tapped the holes, slide the washer (#5 below) onto the 1/4" Jaco fitting (#2). Install this assembly directly into the pipe, securing it with teflon paste or tape only. Pipe seal washers are not included or necessary. The rest of the clamp assembly will not be used. Test for leaks.

Option B: If you drilled the holes, insert the 1/8" Jaco fitting (#2) through the clamp (#3). Place the nylon jam nut (#4) and then the washer (#5) onto the end of the Jaco fitting. Insert the completed assembly into the hole in the pipe and tighten securely. Test for leaks.

Note: If the pipe diameter is larger than 2", two clamps joined together will be required for each hole.

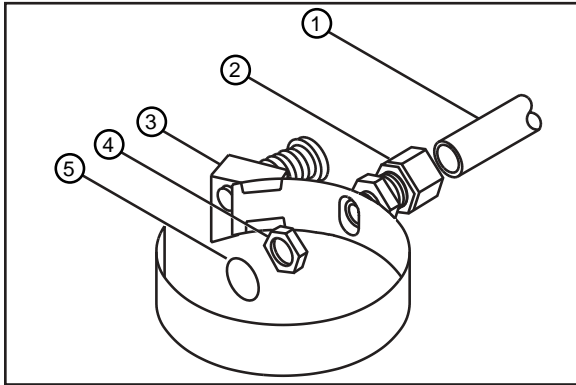

STEP 10

Loosen the nut on the Jaco fitting. Place the loose end of a ten foot section of tubing that is attached to the lower orifice on the tank into the fitting. Hand tighten the nut. **DO NOT USE PLIERS.**

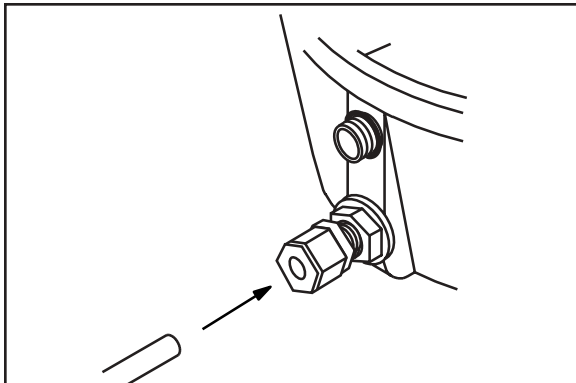

STEP 11

Cut the tubing to the proper length and attach it to the male adapter in the pipe on the suction side of the pump (see F below). Avoid hose kinks and leave a little extra length of tubing in case the feeder needs to be moved for service. Hand tighten the tube nut.

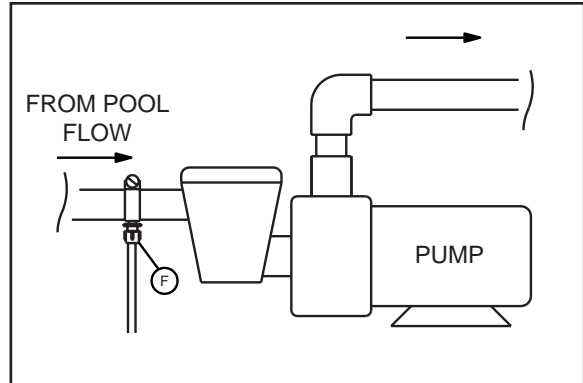

STEP 12

Place a Jaco fitting on one end of the tubing and attach the on/off valve of the strainer assembly (location C below). Hand tighten the fitting.

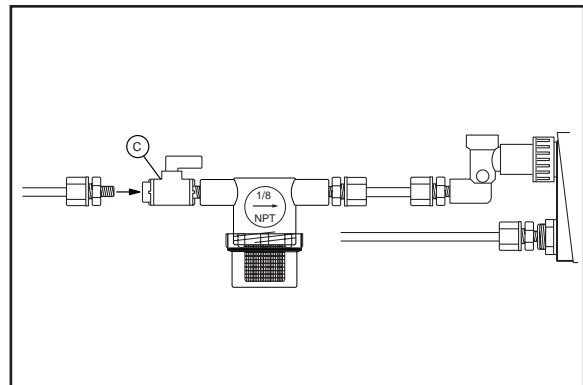

STEP 13

Cut the tubing to the proper length to attach to the male adapter in the pipe on the pressure side of the filter (D below). Avoid hose kinks and leave a little extra length of tubing. Hand tighten the tube nut.

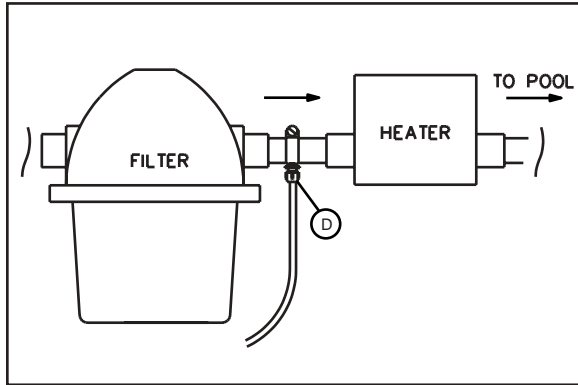

STEP 14

Open any valves between the pool filter system and the pool. Turn on the power to the filter pump and prime the pump. Drain the air from the filter tank

STEP 15

Be sure the on/off valve is ON, handle pointed toward the tank. Water will enter the check valve and begin to fill the tank. Make sure that the ball in the check valve is moving vigorously and that water fills the tank. The water level should stabilize 3/4" from the top of the tank dam.

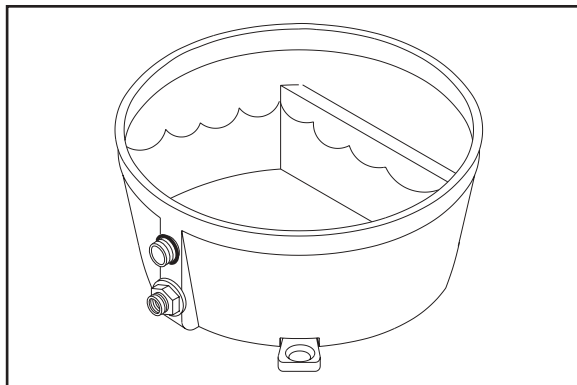

STEP 16

Use the chart below to determine the correct measuring cone for your application. The unit is assembled with cone B.

CONE	DOSAGE	POOL SIZE Gallons
A	3 oz.	50,000+
B	2 oz.*	15,000-50,000
C	1 oz.	2,500-15,000
C	1/4 oz.**	Spa (500-2,500)

* 2 oz. cone factory installed
 ** With 300 Series Controllers in the spa mode

STEP 17

Remove the measuring cup from the hopper.

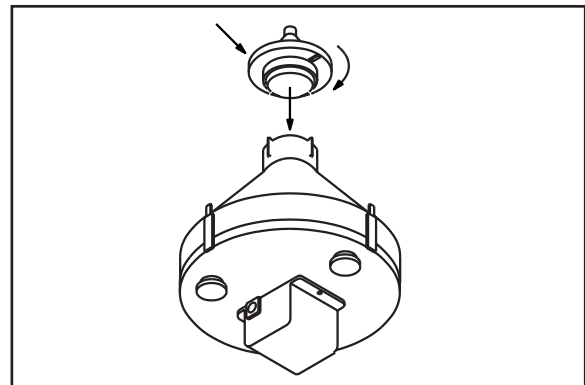

STEP 18

Replace the measuring cup with the appropriate sized measuring cone: A, B or C.

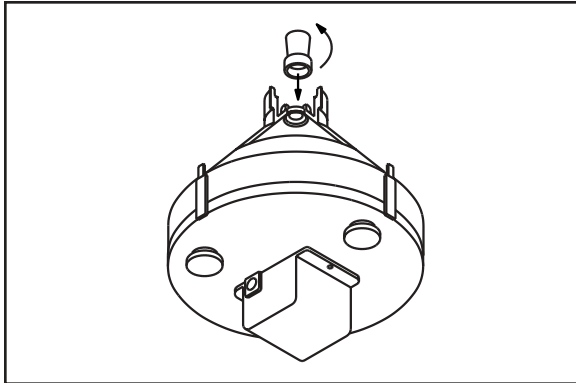

STEP 20

Place the hopper assembly onto the tank and secure.

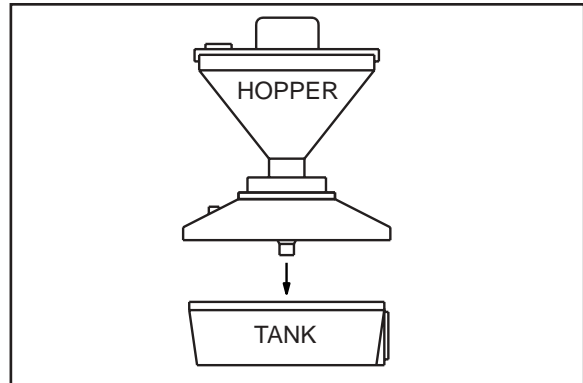

STEP 19

Make sure the white gasket is properly seated, reconnect the measuring cup assembly.

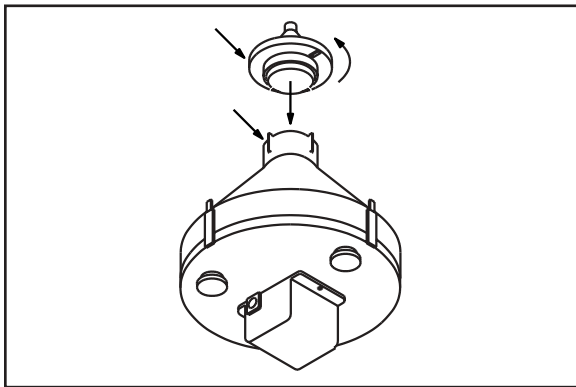

STEP 21

Remove the solenoid cover from the top of the hopper and attach the controller to the solenoid according to the controller installation instructions. Replace the solenoid cover.

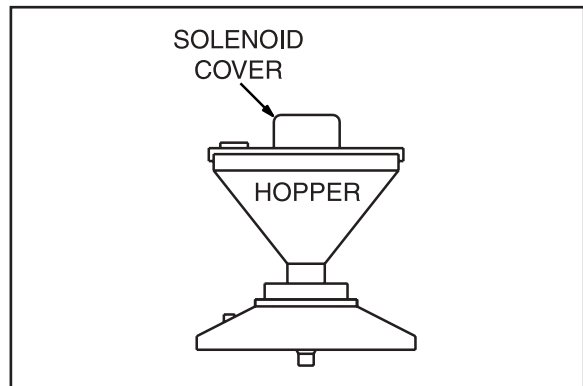

III. EXPLODED PARTS DIAGRAM

No.	Part #	Description	Qty
	G1000	Dichlor Granular Feeder, 120V	
	G1000A	Acid Granular Feeder, 120V	
1	2-250	Funnel	1
2	3-150*	Piston Solenoid, 120V	1
	3-151	Piston Solenoid, 240V	1
3	1-030	Bracket, Solenoid	1
4	1-010	Cover, Solenoid	1
5	1-020	Gasket, Solenoid Cover	1
6	1-094	Hopper Lid White (New Style)	1
	1-095	Hopper Lid Red (New Style)	1
7	1-110	Gasket, Hopper Lid	1
8	1-052	Fill Caps, Set of 3	1
9	4-011	Lid Latch O-ring, Set of 3 (Old Style)	1
10	8-175	Hopper Assembly (New Style)	1
11	2-120	Piston Seat, Upper w/Retainer Ring	1
12	1-175	Measuring Cone Set	1
13	4-030*	Piston Boot	1
14	1-190	Gasket, Collar	1
15	1-290*	Piston, Hopper	1
16	8-135	Measuring Cup Assembly	1
17	2-260*	Piston Seat, Lower	1
18	1-260	Cup Guard	1
19	1-310	Lid, Tank	1
20	1-330	Tank	1
21	2-231	Anchor, Tank, Set of 3	1
22	1-350	Nut, Diverter Valve Assembly	1
23	2-135*	1/8" M x 3/8" Jaco® Fitting	4
24	8-050	Flow Indicator, Clear	1
25	8-110	Strainer Assembly	1
26	8-112	Screen, Strainer Assembly	1
27	8-090*	On/Off Valve, 1/8"	1
28	2-270*	3/8" Tube, 20 Foot, Blue	1
29	2-139	Nylon Jam Nut	2
30	4-190	Washer, Pipe Seal	2
31	5-251	Clamp, Snap Lock	2
32	8-010*	Diverter Valve Assembly	1
33	8-030*	Float Arm Assembly	1
34	8-510	Float	2
35	1-370	Gasket, Diverter Valve Assembly	1
36	8-215	Hopper and Lid Assembly	1

*Suggested stocking parts.

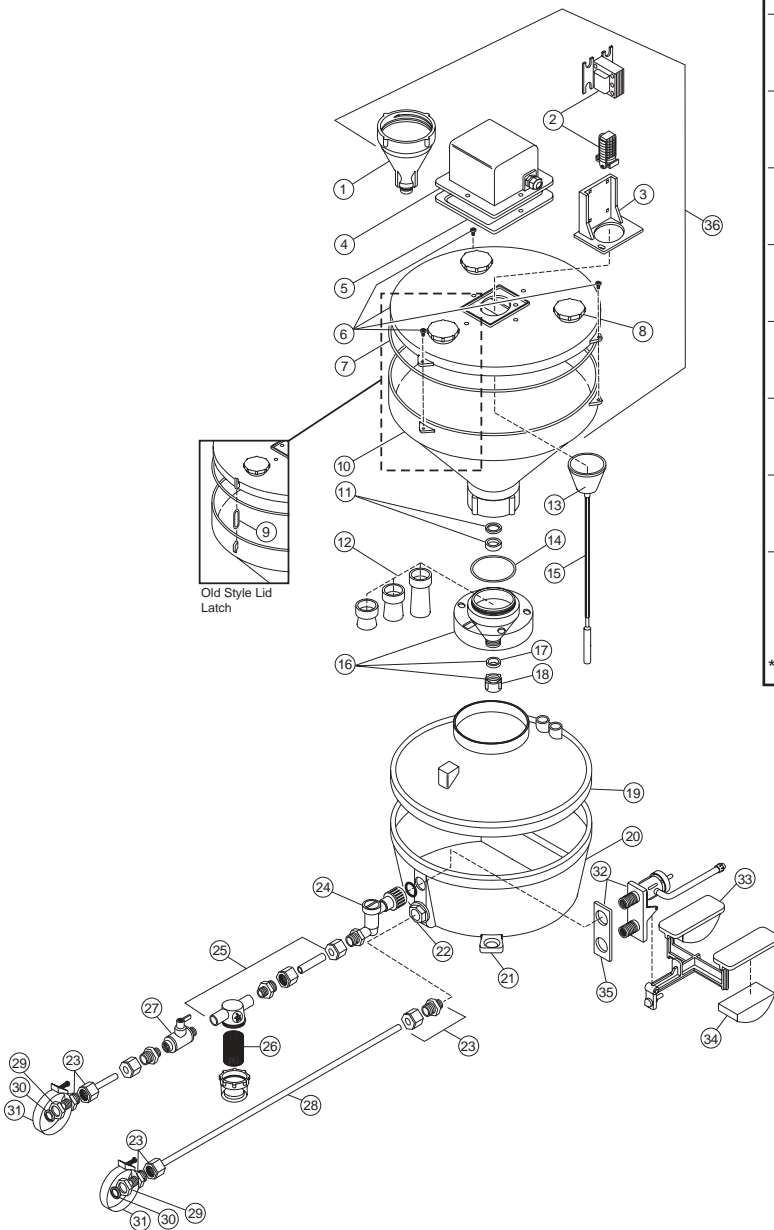

IV. OPERATION

A. PRODUCT DESCRIPTION

When the pool or spa sanitizer drops below the desired level, the controller senses the drop and activates the G1000 feeder. A measured amount of granular sanitizer (dichlor) is then dispensed into the water.

B. PROPER LEVELS

Determine the free chlorine level of your swimming pool or spa using a DPD test kit. It should be between 1.0 ppm and 3.0 ppm. Adjust if required.

Check the pH level of your pool or spa with a test kit. The pH should be maintained between 7.2 and 7.6 to maximize sanitizer efficiency and ensure the accuracy of the controller. A pH level above or below this range will cause inaccurate sensor readings. High or low pH levels can also cause irritation to swimmers and damage the pool and equipment.

C. START-UP OPERATIONS

Before continuing with the feeder installation, install the controller according to the owner's manual instructions.

There are several types of granular sanitizer products available. For this unit, the **granular sanitizer must be dichlor (sodium dichloro-s-triazinetriene)**. The warranty will be void if the feeder is used with any other sanitizer. Read the label on the sanitizer bottle and observe the warning labels on the feeder. **DO NOT MIX CHEMICALS.**

The hopper will hold about eight lbs. of sanitizer. Be sure that no water or moisture gets into the hopper.

The o-ring bands attaching the lid to the hopper are for servicing only. **DO NOT REMOVE THESE BANDS.** Always make sure that all three bands are in place before operating the feeder, otherwise, the piston could be damaged.

D. FILLING THE FEEDER

The G1000 feeder should be filled only through the three holes in the hopper lid. If the lid is removed from the hopper with material in the hopper, the material will flow out the bottom. **DO NOT RE-USE** this material unless it has been caught in a clean, dry container.

DO NOT attempt to **PUSH THE PISTON** back into the hopper while material is still in the hopper. Damage to the piston, solenoid or spring can occur.

Unscrew and remove all three fill caps on the hopper lid. Carefully pour in the granular sanitizer using the funnel provided. Pour sanitizer evenly into all three holes. **DO NOT SHAKE** the feeder to attempt to get more granular material into the unit. Damage to the piston, solenoid spring or rubber boot can occur if the granular material is packed up against the rubber piston boot. Once filled, replace and tighten the caps.

It is recommended that no more than one to two weeks of material be put into the hopper at one time. The hopper on a spa should not be more than half full. Granular material tends to pick up moisture. Attempting to put a large supply in the hopper can result in the material forming chunks which adversely affect the unit's ability to feed.

E. EXTENSION HOPPERS AND EXTENSION BOTTLES

To increase the amount of useable granular material, Watermatic feeders provide the option of using extension hoppers or extension bottles. Extension bottles **MAY NOT** be watertight, so when using bottles, position the feeder in an area that is protected from the elements.

Polaris **DOES NOT RECOMMEND** the use of extension hoppers or extension bottles on pools or spas under 50,000 gallons.

As mentioned above, only use the number of bottles or the amount of material that will be used in a relatively short period of time.

V. MAINTENANCE

A. CLEAN STRAINER SCREEN

See Figure 1 location B.

1. The strainer screen is located on the pressure side of the feeder to protect the unit from being clogged by debris.
2. Always turn the on/off valve of the G1000 OFF while cleaning or backwashing the filter. Remember to turn the valve back ON when the procedure is complete.
3. Regularly examine the movement of the ball in the check valve. If the filter pump is on and the ball is not active, water is not running through feeder.

Be sure the on/off valve is ON. If it is, strainer cleaning may be needed.

- Turn on/off valve to OFF and remove the screen from the strainer. Clean with water and replace. Turn the valve back ON.
- If there is still inadequate water pressure to the feeder, clean the filter.
- If the screen gets clogged regularly, the filter may require service.

B. SANITIZER IN HOPPER

Be sure to check the sanitizer level in hopper and refill it when it is low.

Replace caps tightly after adding sanitizer.

Be sure the funnel is completely dry before pouring the sanitizer.

If water or moisture enters the hopper, the sanitizer will develop lumps and may not feed properly. To change the sanitizer:

- Remove the hopper assembly from the tank and set it over a clean, dry bucket. Depending on the style of the lid, release the three o-ring bands (old style) or unscrew the three screws (newer style) and carefully lift the lid straight up; sanitizer will flow out the bottom of the cup. Clean and completely dry the hopper and measuring cup, then replace the hopper lid. Be careful not to damage the piston.
- Refill the hopper.

C. CLEAN MEASURING CUP

Should the unit fails to dispense sanitizer, check for a clog in the bottom of the measuring cup. If cleaning is necessary,

- Remove the hopper from the tank and turn it upside down. Unthread the measuring cup from the hopper (see Step 17 of Installation instructions). Clean the cup with tap water.
- DRY COMPLETELY WITH A CLEAN TOWEL BEFORE REPLACING.
- Be sure that the piston tip is clean and dry.
- Make sure the collar gasket is correctly seated. Thread on the measuring cup back onto the hopper. Set the hopper assembly back on the tank.

D. ANNUAL MAINTENANCE

Check and/or replace these parts as necessary.

- ORP Sensor, pH Sensor
- Hopper Piston & Attachment Bolt (optional)
- Solenoid w/ Electrical Connectors
- Piston Tip Set
- Collar Gasket
- Tubing (optional)

E. WINTERIZING

If the system is subject to extended shutdowns or is located in colder climates, it is important to winterize the system.

1. Turn off the main power to the controller.
2. Loosen the compression fitting nuts and gently remove the sensors from the tank lid.

The sensor tips must be stored in a protective cap or bottle filled with a liquid solution of one teaspoon salt and three teaspoons water. Mix the solution thoroughly and make sure the solution completely covers the tips of the sensors.

STORE THE SENSORS IN A WARM PLACE. DO NOT EXPOSE SENSORS TO FREEZING TEMPERATURES.

3. Drain the water from the tank.

VI. TROUBLESHOOTING

FLOW

Problem: The gray ball in the flow indicator is not moving or is moving slowly, and the controller ORP reading is above the set point, but the chlorine in the pool is low.

Solution:

1. If the water in the main tank is more than an inch below the dam, the problem is on the inlet side (top tube).
 - The in-line screen/filter may be clogged. Clean the filter.
2. If the water is near the top of the dam, the problem is on the outlet side (bottom tube).
 - The main filter may need to be backwashed.
 - There might be a blocked tube on suction side (lower tube), purge the tube.
 - There may be a pool filter system problem.

FEEDER.

Problem: The ORP controller reading is below the set point and the chlorine is low in the pool.

Solution:

1. The feeder is clogged or there are lumps in the sanitizer. Remove the measuring cup lid, clean it and break up lumps or replace the material.
2. The solenoid may not be working. Check the wiring for corrosion or other damage.
3. Test the sensor and replace it if necessary.
4. Fill the feeder if it is empty.
5. Blown fuse - solenoid not free to move, replace the fuse after freeing the solenoid.
6. Adjust dip switch settings on the controller that are preventing feeding. These switches can be set to prevent ORP feed when pH feeding or when readings are out of range.

CONTROLLER/SENSOR

If the controller is operating properly, one or two lights will be lit on the light bar display (digital display on the C660). The power light will also be illuminated and the feed light will be on.

Problem: No lights are illuminated on the controller and the controller is shut down.

Solution:

1. Check the power to the controller.
2. Check the circuit board.

Problem: The low ORP light is on and the controller is shut down.

Solution: The controller automatically shuts down when ORP reading is less than 100 mV.

1. Check the sensor.
2. There may not be sanitizer in the pool or feeder. Add sanitizer to the pool to raise the ORP reading above 100mV.

Problem: The feed light is off or the power light is off, and the display lights are on but the controller is shut down.

Solution: Check the flow switch or the jumper flow terminal on the back of the module.

Problem: The low ORP light and the high pH light are both on.

Solution: Switch the sensor positions on the controller.

CHEMICAL BALANCE

Problem: The sanitizer level is too high.

Solution:

1. Check the pH level. High pH levels depress the ORP reading.
2. Algaecide or another additive can depress the ORP reading.
3. TDS or cyanuric acid levels are too high.

Problem: The sanitizer level is too low.

Solution:

1. pH level is too low, low pH levels increase ORP readings.
2. Algaecide, non-chlorine shock or other additive is elevating the ORP signal.

Problem: Chemical use is excessive.

Solution:

1. High TDS, nitrates, etc.
2. High organic loading (leaves, insects, small animals, etc).

VIII. LIMITED WARRANTY

This limited warranty is extended to the original consumer purchaser of this Polaris Watermatic G1000 Feeder manufactured by Polaris Pool Systems, Inc., 2620 Commerce Way, Vista, California 92083-8438, USA.

Polaris warrants the unit it manufactures, including all parts and components thereof, to be free of defects in material and workmanship. This warranty does not cover plumbing or normal replacement items, including gaskets and o-rings. The warranty does not cover improper installation of the Polaris Watermatic G1000. Installation instructions should be read before installation and followed carefully. For questions regarding your Polaris Watermatic Feeder, please feel free to call or write us. Please provide the serial number of your unit when you call.

This warranty commences on the date of installation of the G1000 feeder and will remain in effect for a period of one (1) year, but in no event shall it be in effect for more than two (2) years from the date of manufacture of the feeder as established by the serial number.

The limited warranty does not apply if the failure is caused or contributed to by any of the following: power failure or reduction, unusual atmospheric conditions, improper handling, improper storage, winter freezing, abuse, improper installation, unsuitable application, lack of reasonable and necessary maintenance, natural disasters, or repairs/alterations made or attempted by other than Polaris or one of its Authorized Service Centers. Polaris will repair or replace, at its option, a unit or part proved to be defective within the warranty period and under the conditions of the warranty.

The consumer must deliver or ship the unit or warranty parts freight prepaid to the nearest Polaris Authorized Service Center or return it freight prepaid (after proper authorization) to the plant of manufacture. Authorization to return a unit or part to the plant of manufacture must be obtained from the Polaris Customer Service Department. Check with your dealer for the local procedure before exercising this warranty. If further directions or instructions should be required, contact the Customer Service Department at 1-800-822-7933. Be sure to insure your shipments against loss or damage in transit.

Polaris is not responsible for the cost of removal of the unit or part, damages due to removal, or any other expenses incurred in shipping the unit or part to or from the factory or its Authorized Service Centers, or the installation of the repaired or replacement unit. The consumer must bear these expenses.

This warranty does not cover repair or replacement of a unit or part except at our factory or a Polaris Authorized Service Center.

THIS LIMITED WARRANTY IS IN LIEU OF ALL OTHER WARRANTIES EXPRESS OR IMPLIED, INCLUDING THE IMPLIED WARRANTIES OF MERCHANTABILITY AND FITNESS FOR A PARTICULAR PURPOSE, AND ALL SUCH OTHER WARRANTIES ARE DISCLAIMED EXCEPT TO THE EXTENT ANY IMPLIED WARRANTY MAY BE IMPOSED BY STATE CONSUMER LAW. ANY SUCH IMPLIED WARRANTY IMPOSED BY STATE CONSUMER LAW IS LIMITED IN DURATION TO ONE (1) YEAR FROM DATE OF PURCHASE. IN NO EVENT SHALL POLARIS BE LIABLE FOR INCIDENTAL OR CONSEQUENTIAL DAMAGES OF ANY NATURE OR KIND OR FOR DAMAGES TO PERSONS OR PROPERTY, INCLUDING ANY DAMAGE RESULTING FROM THE USE OF THE POLARIS WATERMATIC G1000 FEEDER WITH A SUBSTANDARD POOL CIRCULATION SYSTEM.

Some states do not allow limitations on how long an implied warranty lasts, or the exclusion or limitation of incidental or consequential damages, so the above limitations may not apply to you.

This limited warranty is valid only in the United States of America and Canada, and it does not apply to Polaris Watermatic Feeders sold or installed in any other country.



USA: 2620 Commerce Way, Vista, CA 92083-8438 • 760-599-9600 • 1-800-VAC-SWEEP (USA and Canada only)

Florida Warehouse: 10453 Tillery Road, Spring Hill, FL 34608

Australia: Unit 18, 1-7 Short Street, Chatswood, NSW 2067 • 02-9882-1111 • ACN 080 168 092

Europe: C/Osona s/n. (Pol. Ind. El Ramassar), 08520 Les Franqueses del Vallés, Barcelona, Spain • +34 93 840 25 85

www.polarispool.com