

# INSTALLATION INSTRUCTIONS

## 2 1/2" POLY GUNITE JET

### (P/N 210-3700)

#### INSTALLATION PROCEDURES AND PRESSURE TESTING

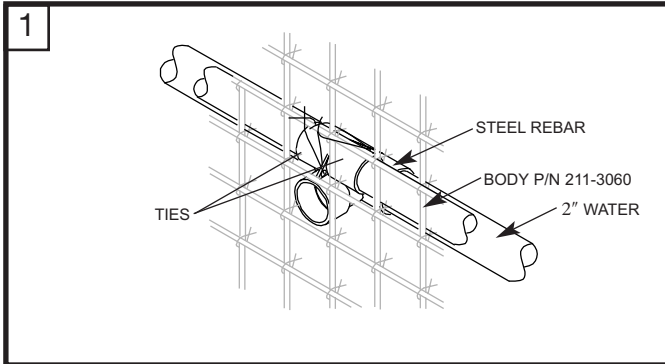

1 Hang Guntie Poly jet Body with ties through preset holes onto steel rebar.

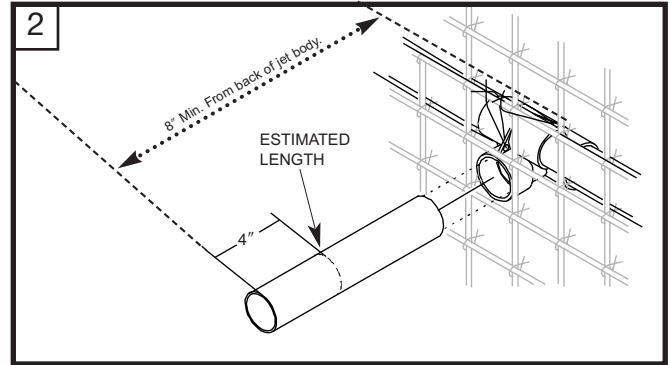

2 Estimate needed length of 2 1/2" pvc pipe by thickness of wall. Cut 2 1/2" pvc pipe at least 4" longer than estimated. Then glue 2 1/2" pvc pie to Body.

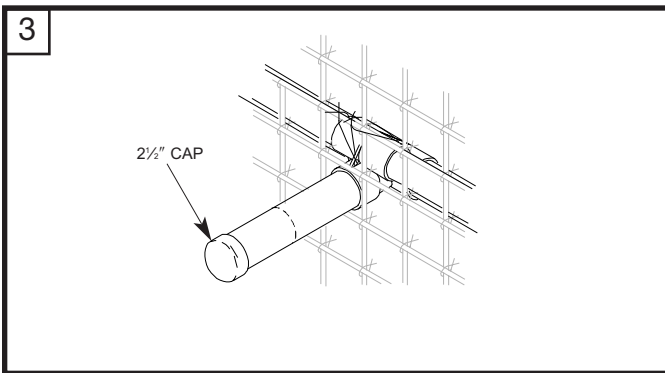

3 Glue 2-1/2" cap onto end of pipe for pressure test before guniting.

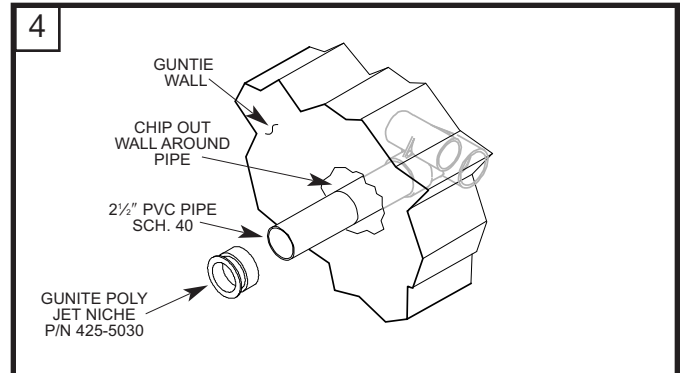

4 After pool guniting scoop around pipe. Before plastering cut the 2-1/2" pvc pipe inside the wall and glue on the Guntie Poly Jet Plaster Niche P/N 425-5030 (not included). Cover niche with tape then plaster over niche.

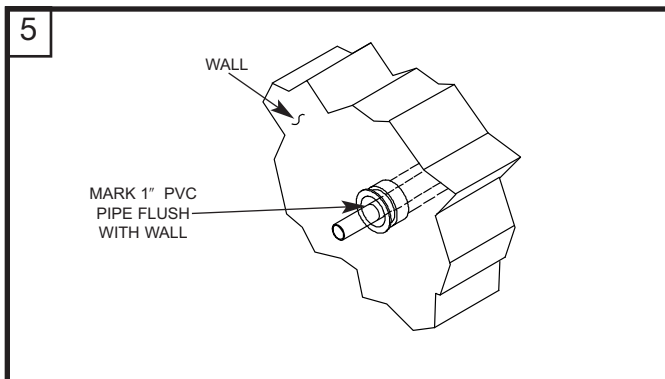

5 Make a mark on the 1" pvc pipe flush or even with the end of the 2 1/2" pipe

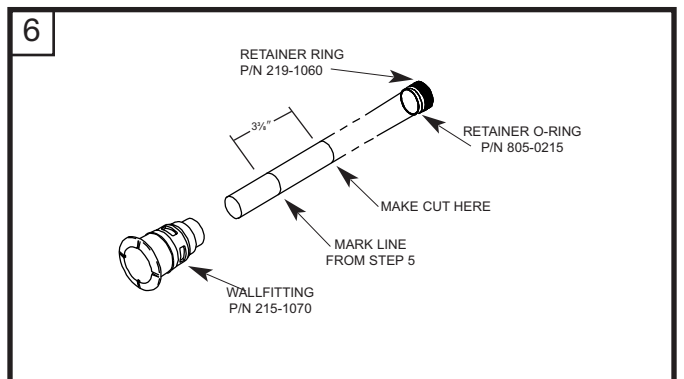

6 Unscrew 1" pvc pipe from body and cut 3/8" inward from a mark towards retain-er ring, then glue wallfitting to 1" pvc pipe.

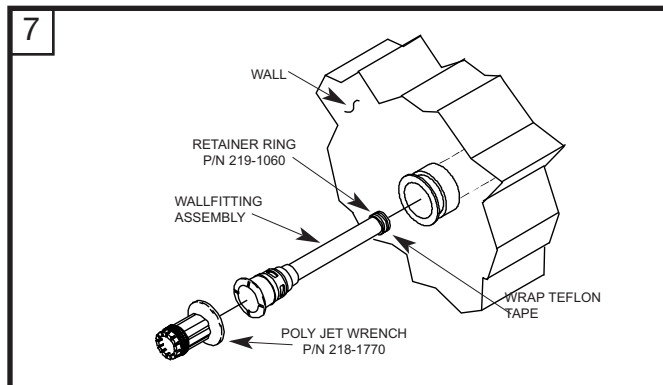

7 Wrap Teflon tape on retainer ring if necessary and thread the 1" PVC pipe back into body with poly jet wrench, making sure of a snug fit.

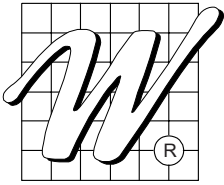

# INSTALLATION INSTRUCTIONS CON'T

## 2 1/2" POLY GUNITE JET

### (P/N 210-3700)

#### INSTALLATION PROCEDURES AND PRESSURE TESTING

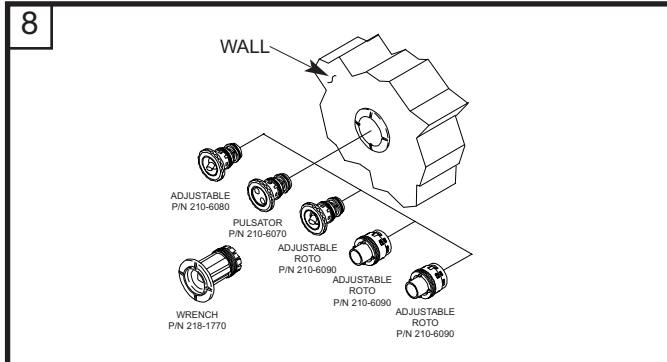

If installing any of the internals above use a poly jet wrench to screw internal into wallfitting. Also available are metal escutcheons to cover plastic wallfitting (See Below).

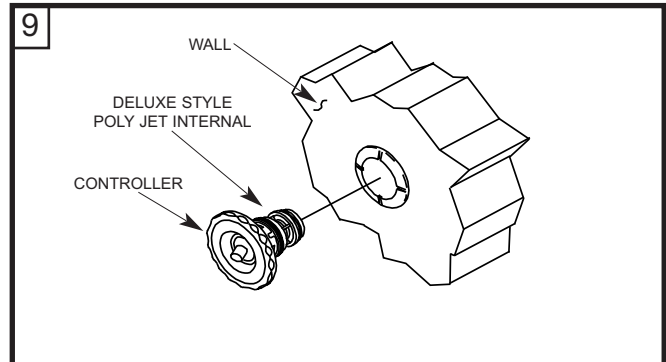

If installing a deluxe style internal simply into into wallfitting and turn clockwise hand tightening. When tight turn counterclockwise to adjust to water flow.

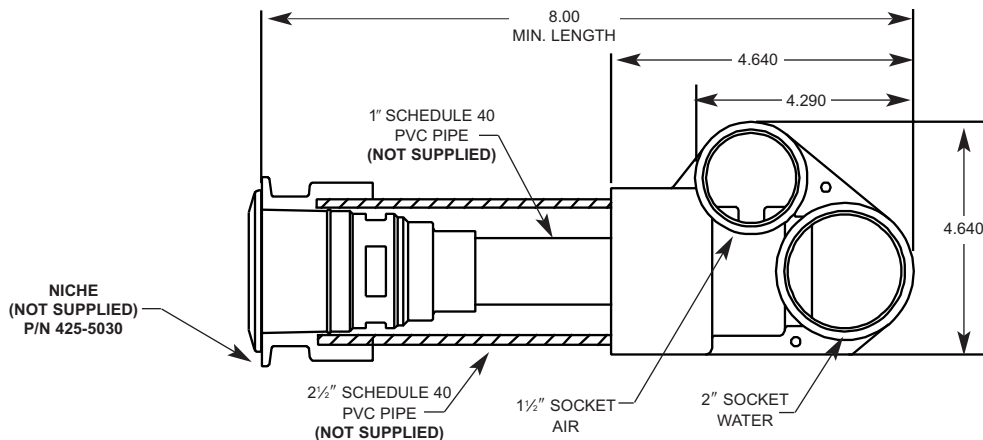

### POLY JET INTERNALS & ACCESSORIES

Always use at least one Non-Adjustable internal per spa to prevent dead-heading pump.

#### Standard Internals

- 

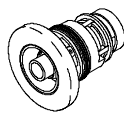
ADJUSTABLE PULSATOR  
P/N 210-6060  
WHITE  
10 GPM
- 

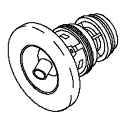
ADJUSTABLE ROTO  
P/N 210-6120  
WHITE  
10 GPM
- 

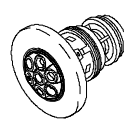
ADJUSTABLE ROTO  
P/N 210-6100  
WHITE  
10 GPM
- 

ADJUSTABLE MASSAGE (7 NOZZLE)  
P/N 210-6710 WHITE  
10 GPM

**Non-Adjustable**

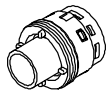

WHIRLPOOL  
P/N 210-9790  
38 GPM

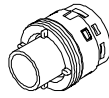

MONSTER  
P/N 210-8750

FOUR DIFFERENT ORIFICES INCLUDED

- 5/16" - 10 GPM
- 3/8" - 13 GPM
- 7/8" - 17 GPM
- 1/2" - 22 GPM

#### Deluxe Series

- 

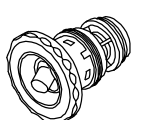
ADJUSTABLE PULSATOR  
P/N 210-6070 WHITE  
10 GPM
- 

ADJUSTALBE ROTO  
P/N 210-6090 WHITE  
10 GPM
- 

ADJUSTABLE ROTO  
P/N 210-6080 WHITE  
10 GPM
- 

ADJUSTABLE MASSAGE (7 NOZZLE)  
P/N 210-6700 WHITE  
10 GPM



#### ACCESSORIES

- 

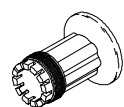
STAINLESS STEEL TRIM ESCUTCHEON  
P/N 916-6000
- 

WRENCH  
P/N 218-1770
- 

HANDHELD JET  
P/N 210-3200  
10 GPM