



OmniLogic[®]

Automation and Chlorination

Operation Manual

A photograph showing the OmniLogic control panel, a tablet, and a smartphone. The control panel is a vertical metal cabinet with a screen at the top displaying the 'OmniLogic' logo and some data. The tablet and smartphone show the software interface with various charts and data points.

Contents

Introduction.....4

Bodies of Water.....7

Favorites.....19

Config.....27

Simple Mode.....33

Web Enabled Control.....35

Warranty.....33

HLBASE

Hayward Pool Products
620 Division Street, Elizabeth NJ 07207
Phone: (908) 355-7995
www.hayward.com



HAYWARD®

IMPORTANT SAFETY INSTRUCTIONS

When using this electrical equipment, basic safety precautions should always be followed, including the following:

- **READ AND FOLLOW ALL INSTRUCTIONS**
- **WARNING:** Disconnect all AC power during installation.
- **WARNING:** Water in excess of 100 degrees Fahrenheit may be hazardous to your health.
- **WARNING:** To reduce the risk of injury, do not permit children to use this product unless they are closely supervised at all times.
- **WARNING:** Do not use the OmniLogic to control fire pits or related equipment.
- A green colored terminal marked “Grounding” is located inside the wiring compartment. To reduce the risk of electric shock, this terminal must be connected to the grounding means provided in the electric supply service panel with a continuous copper wire equivalent in size to the circuit conductors supplying the equipment.
- One bonding lug for US models (two for Canadian models) is provided on the external surface. To reduce the risk of electric shock, connect the local common bonding grid in the area of the swimming pool, spa, or hot tub to these terminals with an insulated or bare copper conductor not smaller than 8 AWG US / 6 AWG Canada.
- All field installed metal components such as rails, ladders, drains, or other similar hardware within 3 meters of the pool, spa or hot tub shall be bonded to the equipment grounding bus with copper conductors not smaller than 8 AWG US / 6 AWG Canada.
- **SAVE THESE INSTRUCTIONS**



Table of Contents

| | | |
|--|---|----|
| Introduction | Idle and Home Screen..... | 4 |
| | Power Button..... | 5 |
| | Selecting a Body of Water..... | 5 |
| | Favorites..... | 6 |
| | Navigation Buttons..... | 6 |
| Bodies of Water Control Screens | Filter Pump..... | 7 |
| | Schedules..... | 8 |
| | Pump Speed..... | 9 |
| | Countdown Timer..... | 11 |
| | Heater..... | 11 |
| | Heater Priority..... | 12 |
| | Chlorinator..... | 13 |
| | pH Dispense..... | 15 |
| | ColorLogic..... | 16 |
| | Other Lights..... | 17 |
| | Cleaners..... | 17 |
| | Water Features..... | 17 |
| | Schedules Button..... | 18 |
| | Spillover..... | 18 |
| | Freeze Protect Override..... | 19 |
| Favorites | Alarms Button..... | 19 |
| | Daylight Button..... | 20 |
| | Features/Lights/Heaters/Backyard Buttons..... | 20 |
| | Favorites Button..... | 21 |
| | Themes Button..... | 24 |
| Config | Config Button..... | 27 |
| | Config Wizard..... | 27 |
| | System Info..... | 27 |
| | BackupConfig..... | 27 |
| | Restore Config..... | 28 |
| | Display..... | 28 |
| | Network..... | 28 |
| | Web Server..... | 28 |
| | Date/Time..... | 28 |
| | Language..... | 29 |
| | Data Log..... | 29 |
| | Shell Command..... | 29 |
| Wifi Bridge..... | 30 | |
| Upgrade | Upgrade Firmware..... | 30 |
| | Installing New Language..... | 31 |
| Simple Mode | Simple Mode..... | 33 |
| Web Enabled Control | Web Enabled Control..... | 35 |
| Warranty | OmniLogic Limited Warranty..... | 37 |



Introduction

This manual assumes that the OmniLogic has been installed and configured according to the Installation Manual. The OmniLogic can now be programmed with user desired settings such as schedules, themes, and favorites. This manual will also explain how to manually turn pool equipment on/off, program settings for specific equipment, view pool equipment status and conditions, and more.

Now that the initial configuration has been completed, the OmniLogic will automatically go to the Home Screen or Idle Screen. All settings and operation functions can be accessed from the Home Screen. Note that if the OmniLogic local terminal is not touched for more than two minutes, the Idle Screen will be displayed.

Using the Local Touchscreen Terminal

The OmniLogic uses a local touchscreen terminal as the main interface with the device. Once configured, the OmniLogic can be controlled remotely using various Hayward remote terminals or, when connected to the home's network, by Internet enabled devices such as computers, tablets and phones. The local terminal must be used to access the Configuration Wizard. The Configuration Wizard is used for initial configuration (completed during the installation process) and for any changes to existing configuration.

Idle Screen

The OmniLogic Local Terminal will display the idle screen after two minutes of user inactivity. When the filter pump is on, the Idle Screen will display the current temperature of the Body of Water shown in the upper left corner. If the OmniLogic is configured to control two Bodies of Water, the idle screen will toggle between both. On the right side of the screen, the air temperature will toggle with the date.

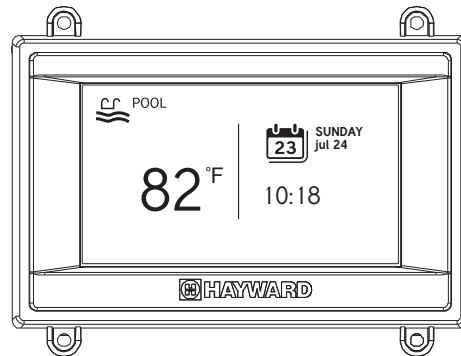

Home Screen

When the idle screen is touched, the OmniLogic will display the Home Screen. This screen will give the user access to all functions, settings and configuration options.

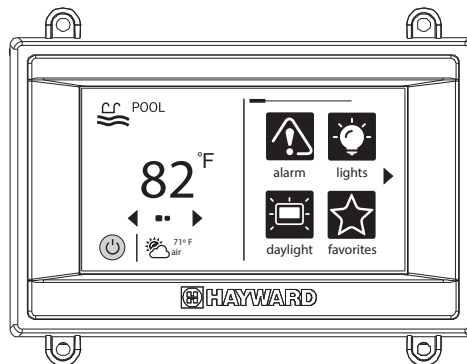



Power Button

The power button is displayed at all times when the OmniLogic is not idle. When touched, it offers the following 4 functions:



Shut Down - When Shut Down is selected, the OmniLogic will turn off all pool equipment and report when it is safe to remove power. When this message is displayed, you can either power off the unit or restart the OmniLogic by touching the large power button displayed on the left side of the screen.

Service Mode - Service Mode will turn off all pool equipment and disable all remote controls including networked devices. Service Mode is useful to prevent scheduled operation and disable remote operation while servicing the pool. After selecting Service Mode, there are two options:

Service Mode (Standard): The OmniLogic will remain in Service Mode until you manually exit. To exit Service Mode, touch the power button and select the Service Mode button again.

Service Mode Timed: Before entering Service Mode, you will select a Service Mode timeout. This is the amount of time that the OmniLogic will stay in Service Mode before automatically exiting. The timeout can be set between 1-96 hours. There is no need to exit Service Mode manually.

Features Off - Features Off offers a quick way to turn off all equipment (except the filter pump, heater, ColorLogic lights and chlorination if running because of a schedule) with a single touch of a button.

Simple Mode - Simple Mode is a customizable screen that can be set up for quick access to your Favorites (page 21). You can set up only the Favorites that you want shown while in Simple Mode. Because it's customizable, Simple Mode can provide a convenient way to access the most common functions for owners as well as a handy solution to limit access to other users. For information on how to create and delete Simple Mode functions, refer to the "Favorites" section in this manual as well as page 33. The MSP ID number is needed when entering and exiting Simple Mode.

Selecting a Body of Water - Left Side of Home Screen

The left side of the Home Screen allows you to select and control a Body of Water. If more than one Body of Water is used (typically a pool and spa), pressing the left and right arrows in the middle of the screen will toggle between the Bodies of Water.

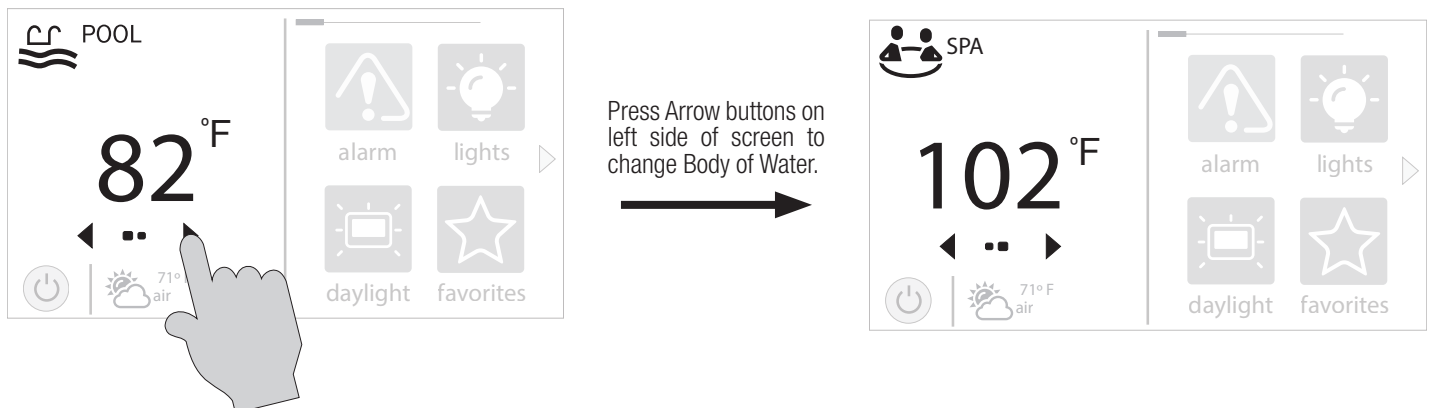

Controlling a Body of Water

When the desired Body of Water is displayed, touch the left side of the screen to advance to the Body of Water Features Screens. The items shown on the Features Screen relate to that Body of Water ONLY. To control a different Body of Water, select the desired Body of Water at the Home Screen first, then go to the Features Screens.

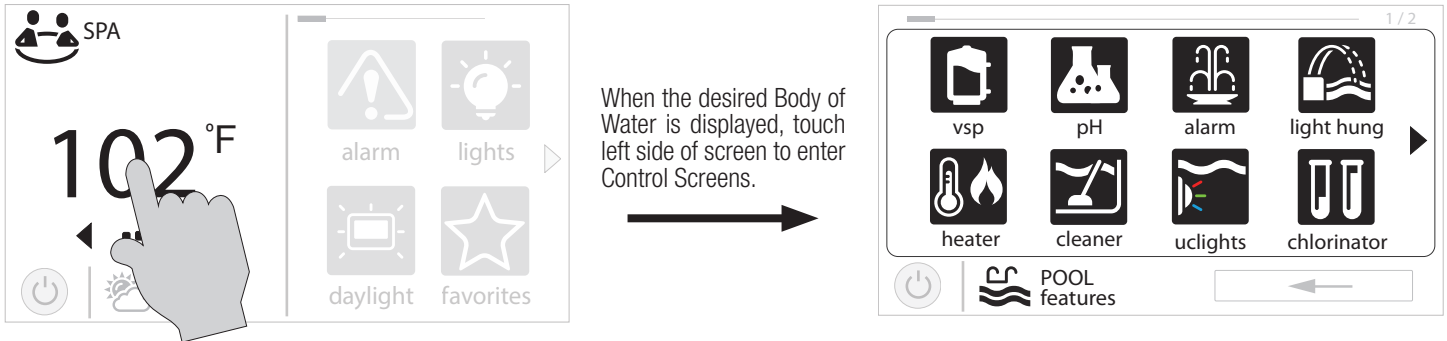

The various buttons shown in the Body of Water Features Screens are related to initial configuration. For example, if you configured a gas heater to heat the Spa Body of Water, the heater setting for the gas heater will be found in the Spa Features Screens.

Favorites - Right Side of Home Screen





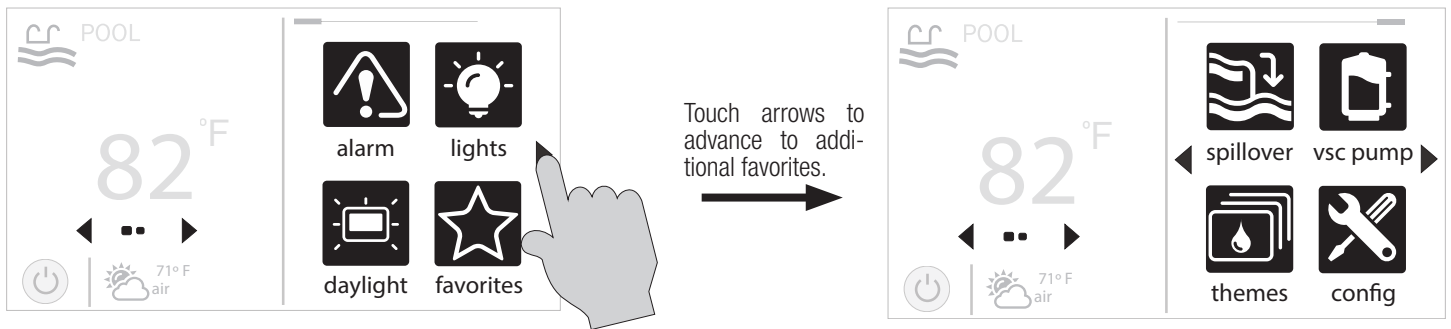





The right side of the Home Screen is Favorites. These buttons offer universal control for Backyard equipment and all Bodies of Water regardless of which one is displayed. Up to four Favorite buttons will be shown on the home screen. To access more Favorites, touch the arrows to the left or right of the Favorite buttons.

Note that some default buttons will appear on the Favorites Screen. These buttons are related to your initial configuration settings and are automatically created. In addition, custom "Favorite" buttons can also be added. The OmniLogic supports up to 50 Favorites for quick easy access to commonly used functions.



Navigation

The OmniLogic has been designed to be intuitive allowing most users the ability to navigate with little instruction. Below, a list of commonly used buttons are explained. As you navigate through the various screens, these buttons will likely be displayed. Some sections of this manual may refer to buttons that are specific to certain types of pool equipment. You'll find more information about those buttons under their corresponding section. If your installation does not include that particular equipment, those sections can be skipped.

-  **Save** - Touch this button to save your selection.
-  **Cancel** - Touch this button to cancel your selection.
-  **Advance** - Touch this button to advance to the next screen.
-  **Back** - Touch this button to return to the previous screen.
-  **Add** - Touch this button to add an item.
-  **Delete** - Touch this button to delete a highlighted item.
-  **Turn On or Enable** - This button will either manually turn on pool equipment or enable a function.
-  **Turn Off or Disable** - This button will either manually turn off pool equipment or disable a function.
-  **Schedule** - Touch this button to schedule a function.
-  **Countdown Timer** - Touch this button to set a countdown timer.
-  **Back** - Touch this button to return to a previous screen.



Body of Water Features and Control Screens

As previously stated, the Body of Water Features Screens allow you to control functions and equipment for a particular Body of Water. Making a change will not affect other Bodies of Water. For example, if the Pool is being displayed when entering the Features Screens, only the pool will be affected by any changes or settings that you make. The contents of the Features Screen is a result of how the OmniLogic was configured using the Configuration Wizard. If equipment is missing or does not belong in the Body of Water Features Screen, you may have to go back to the Configuration Wizard and correct the configuration of that equipment.

An example of a Features Screen is shown below. In this example, we are looking at the Pool (shown in lower left of screen). The arrow button on the right means that there are more Features Screens if we advance.

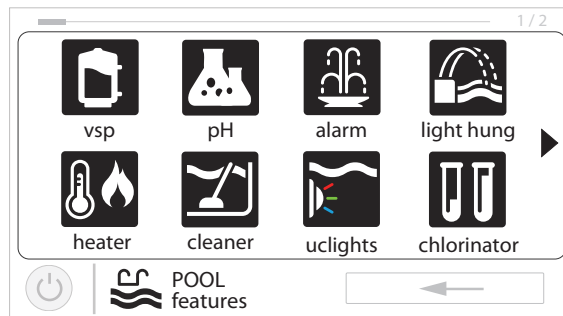

Depending on the equipment that has been configured in your system, your screens will likely be different. The purpose of this section is to explain how Features and Control Screens work as well as show some common equipment examples which will help familiarize you with the interface. Even though some of your equipment may be different, you should see similarities in the following examples that will help you create and change settings for all the equipment in your Features Screens.

The following examples will be shown for the Pool only. All of the equipment shown in the Features Screens have been initially configured in the Configuration Wizard to operate with the Pool. You may have also configured the same type of equipment to operate with a different body of water. For example, you may have a heater for the pool and a second heater for the spa. The following information should help you understand how to control all of your equipment, regardless of which Body of Water is selected.

Control Screens

After an item has been selected in the Features Screen, you'll be brought to a Control Screen. Control Screens are where you will actually make changes to the pool's equipment settings. To change a setting, you'll first select the Body of Water, then select the feature you'd like to change in the Features Screen, then make your change in that feature's Control Screen.

Filter Pump

In the example below, a variable speed pump which was named "vsp" has been configured to be used with the Pool in the Configuration Wizard. Touching the "vsp" button in the Features Screen will bring you to a pump Control Screen which will let you manually turn on/off the pump, set a schedule, set a speed, apply a countdown timer and view the status. Single speed and two speed pumps will have a similar Control Screen.

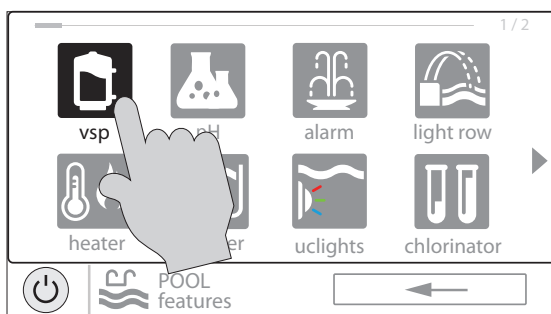

Pool Features Screen

Touching the pump button brings you to the pump control screen.

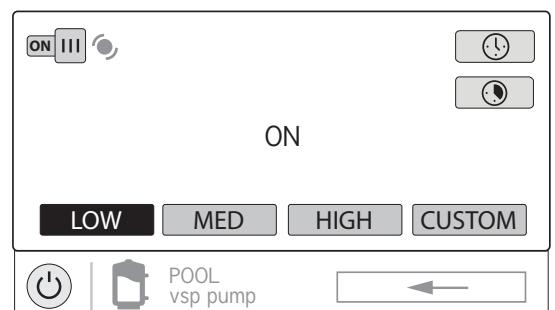

Pump Control Screen

Turn On / Turn Off - Slide this switch manually to turn on/off the pump. This will override schedules or timer settings.

Status of Equipment - This is an indicator only. When lit up and in motion (shown below), the equipment is active. When grayed out and stationary, equipment is off.

Change Speed - Manually select the desired speed. This will not be shown for single speed pumps. Low, Med, and High are fixed speeds. The Custom button will bring you to a screen that allows you to select a speed based on percentage or RPM (determined during configuration).

Set Schedule - Touch this button to add/delete a schedule for the filter pump or to enable/disable an existing schedule.

Countdown Timer - Touch this button to set a countdown timer for the filter pump.

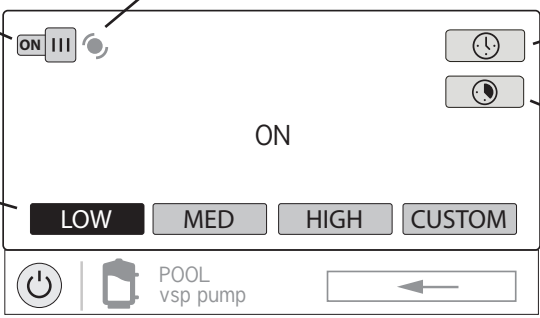

Add a Schedule

If the "Set Schedule" button is touched, you'll be brought to the pump schedule screen below. Here you can add, delete, edit, enable and disable schedules. Because there have been no schedules set up, the screen is blank. Touch the Add button (+) to add a schedule for the pool pump.

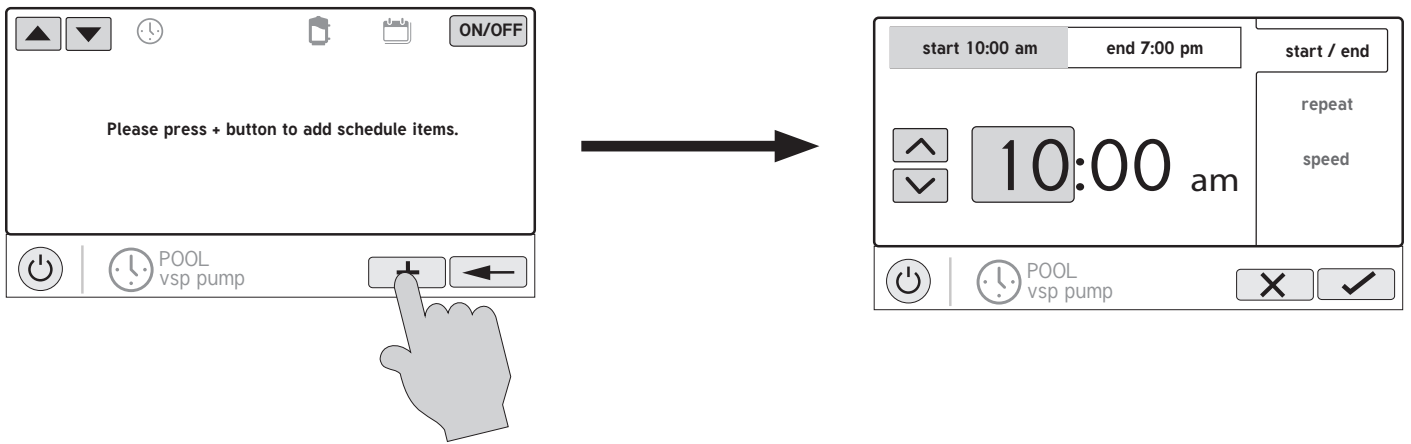

Set Schedule Time

Refer to the screen below to set the start and stop times. When finished, touch "repeat".

Set Start Time - Select this button to edit the start time. The pump will start at the time shown.

Edit Time - Use these buttons to change desired time.

Select Field - Touch Hours, Minutes or AM/PM to edit.

Set End Time - Select this button to edit the end time. The pump cycle will end at the time shown.

Set Schedule Frequency - Select how often you'd like the schedule to run (weekdays, weekends, all week or custom).

Set Pump Speed - Select this button to change the pump speed for the schedule.

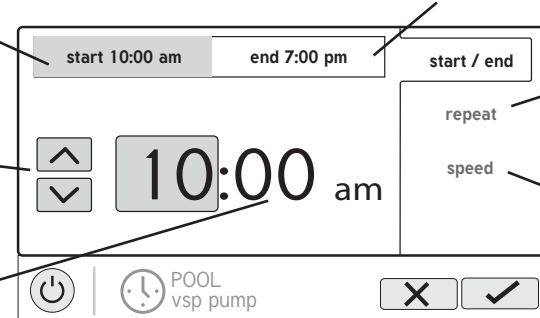



Set Schedule Frequency

Refer to the screen below to select how often you'd like the schedule to run. If "custom" is selected, you'll be asked which day(s) of the week you would like the pump to run. Touch "speed" when finished.

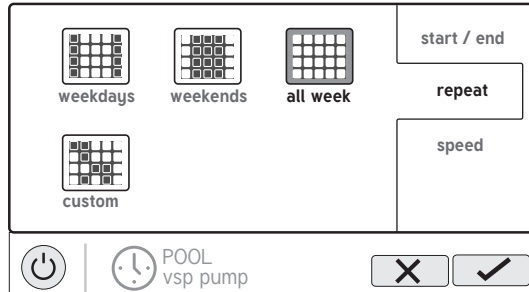

Set Pump Speed

Refer to the screen below to select the pump speed during the schedule. If custom is selected, you'll be asked to set the % pump speed or RPM depending on the setting. When finished, touch the Save button to save the schedule.

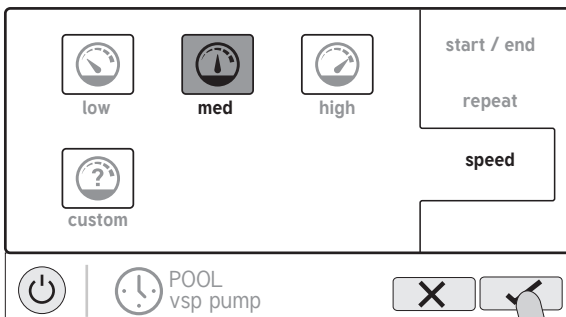

After saving, you'll be brought back to the pump schedule screen. The new schedule will be displayed.

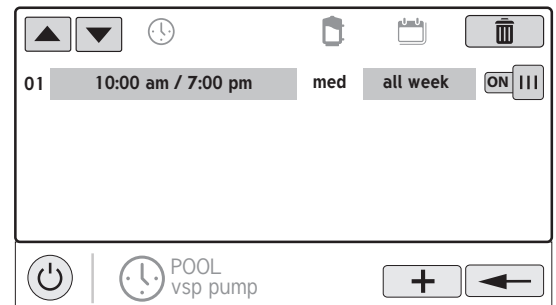

NOTE: If you intend to run the pump at different speeds throughout the day, create additional schedules. You can start a new schedule on the same minute that the previous one ends. If schedules overlap, the newest schedule's start time will take priority by ending the previous schedule early. You can create up to 20 schedules per device.

Edit a Schedule

To edit a schedule, touch the schedule as shown below. You'll be brought back to the screen which will allow you to set times, speed and frequency.

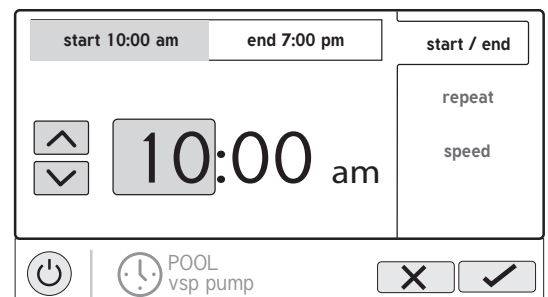
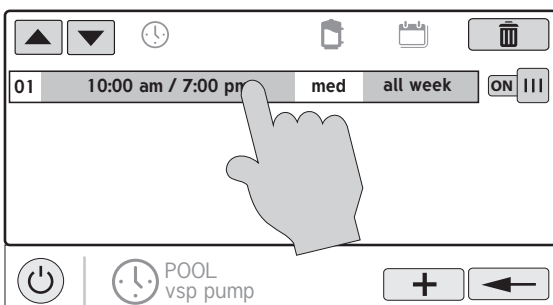

Turning a Schedule Off

There may be circumstances when you will want to turn off a schedule temporarily. To do this, slide the On/Off button to "Off". The schedule will remain off until you go back to this screen and turn it on.

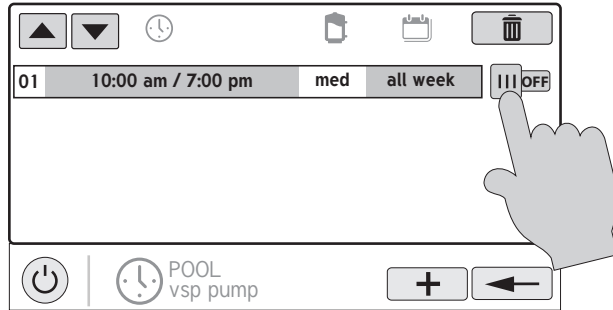

Deleting a Schedule

Schedules can be deleted when they are no longer necessary. To delete a schedule, select the schedule and touch Delete as shown below. A Delete button should appear on the side of the schedule. Touch this Delete button to remove the schedule.

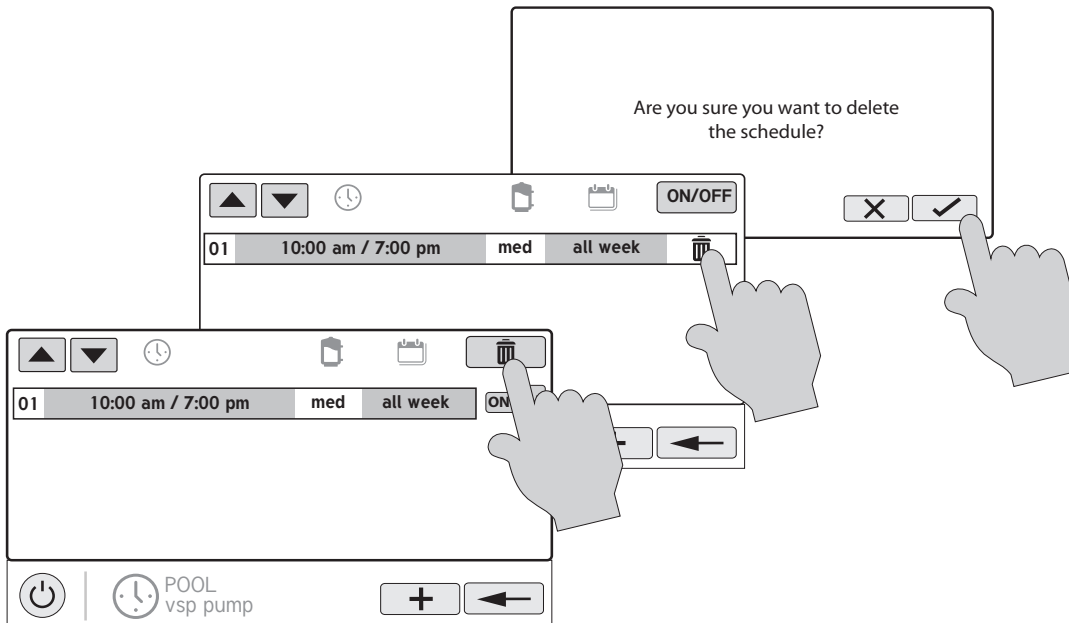

Countdown Timer

A Countdown timer runs or enables equipment for the amount of time specified. You can initiate the Countdown timer at the equipment's control screen. At the countdown screen, set the desired countdown time. In this case, the timer will run the pump for the specified countdown time. If the equipment is already running due to a schedule, the countdown timer setting will override the schedule and turn off at the end of the countdown interval. If the equipment is off, the countdown timer will turn it on for the duration/speed that has been set.

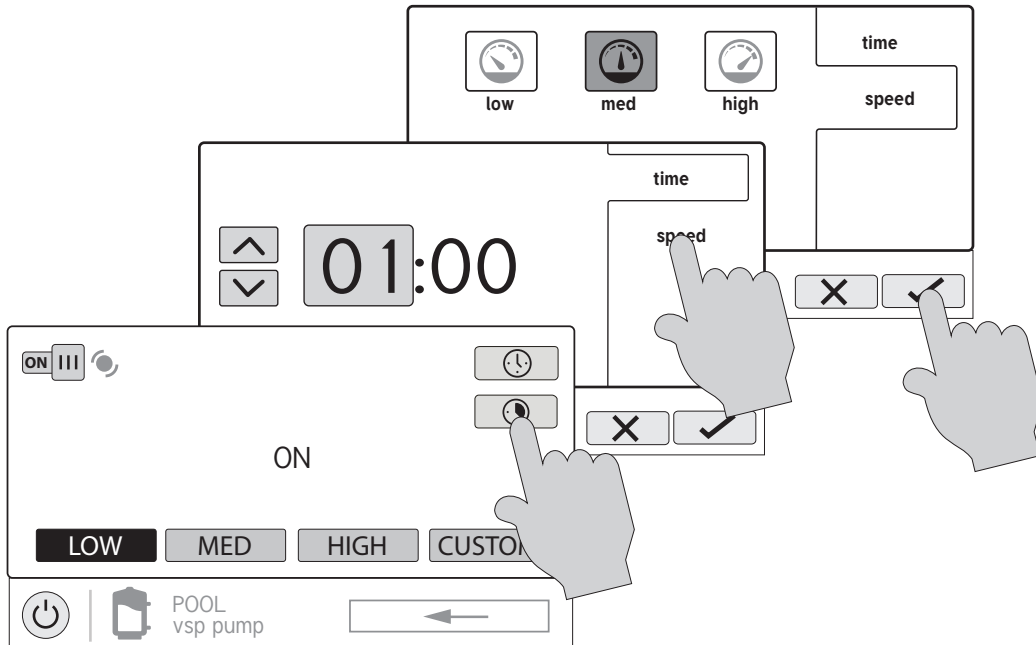

Heater

Touching the Heater button in the Features Screen will let you enable/disable heaters, set priority, set temperature, set a schedule and view the status of the heater for the selected Body of Water. An example of the heater Control Screen is shown below:

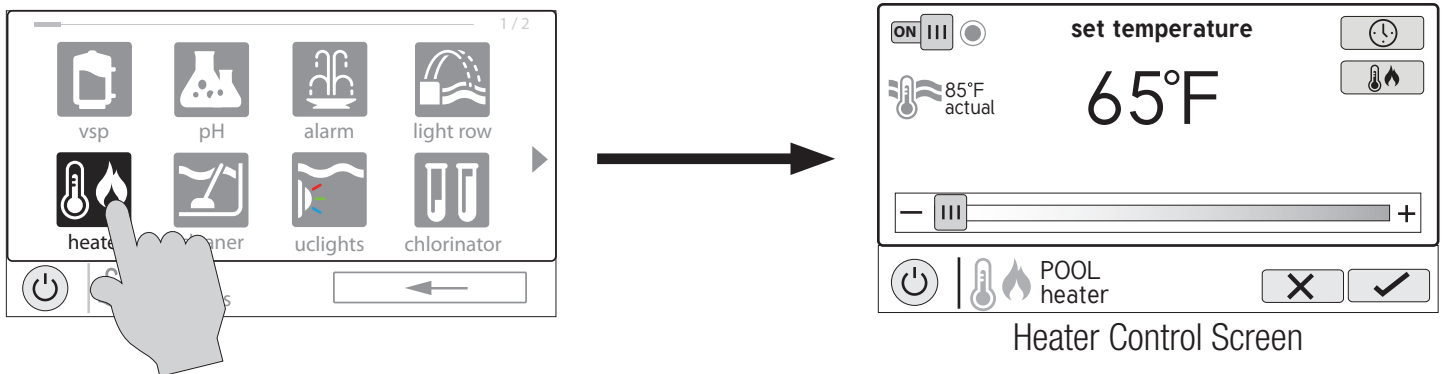

Enable / Disable - Slide this switch to enable and disable the heater. The setting will not take effect until the Save button is touched. To turn on the heater, adjust the setpoint higher than the actual Body of Water temperature and then Save.

Change Setting- This slider will raise and lower the heater setpoint setting.

Status of Equipment - When grayed out and stationary, equipment is currently idle. When in motion, the heater is actively heating.

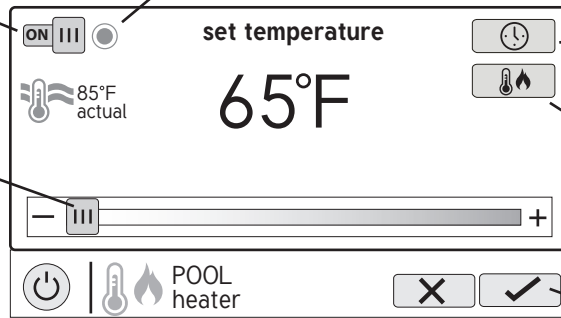

Set Schedule - Touch this button to set a schedule for the heater.

Set Priority - If more than one heater is configured for the Body of Water, use this button to set priority and enable/disable physical heaters.

Save Setting - Setting is not saved until this button is pushed.

Setting and Changing Priority

If there is more than one heater configured for the body of water, the Set Priority button will appear in the Heater Control Screen. If the Priority heater can not meet the demand for heat, the next heater will be allowed to operate. Use Priority to maximize efficiency by allowing the most cost effective heater(s) to run first.

The example below shows how to change priority to run the heat pump first, then, if it can't meet the demand for heat, the gas heater will be allowed to operate. Note that the time interval used for heater priority can only be changed in the Configuration Wizard. Note that a time interval setting of "0" will eliminate priority and always run both heaters at the same time.

Enable and Disable Heaters - When "Select Source" is highlighted, touching a heater button will enable and disable that heater. A grayed out heater is disabled.

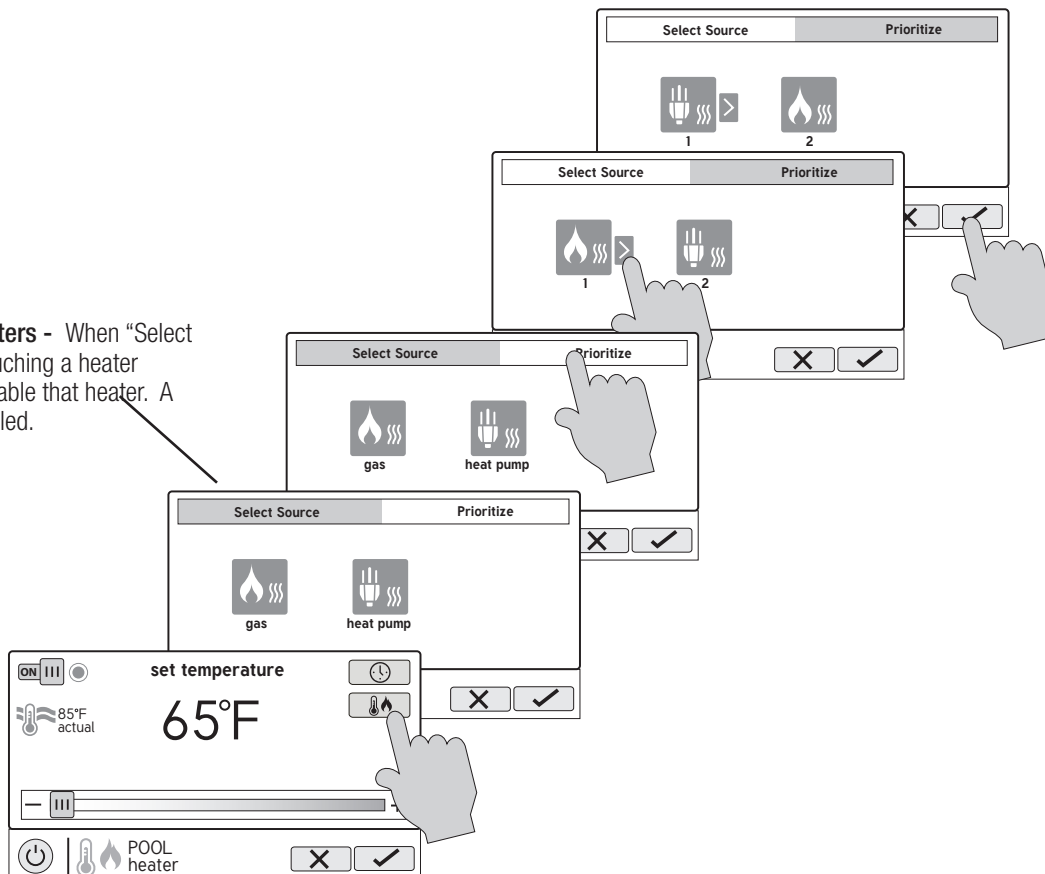

Chlorinator

If a chlorinator has been configured in the Configuration Wizard, you will see it in the Features Screen. Touching the chlorinator button will bring you to the Chlorinator Control Screen that will allow you to enable/disable the chlorinator, set a schedule, super chlorinate and view/change diagnostics. A sample screen is shown below. For schedules, refer to the previous examples in this manual.

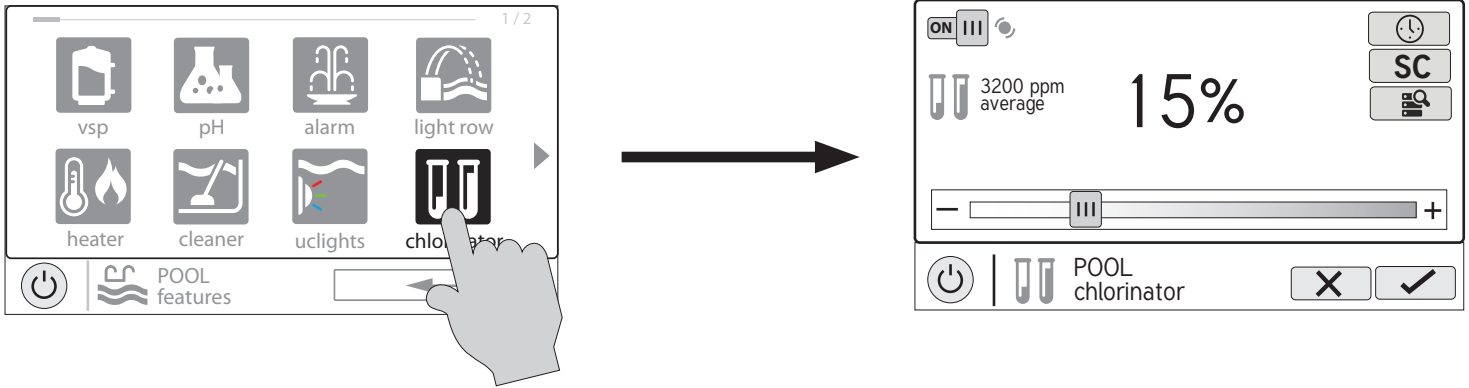

Enable / Disable - Slide this switch to enable and disable the chlorinator and then touch the Save button.

Change Setting- This slider will raise and lower the chlorinator setpoint setting. If an HL-CHEM is used and ORP is enabled, the adjustment will be displayed in "mV".

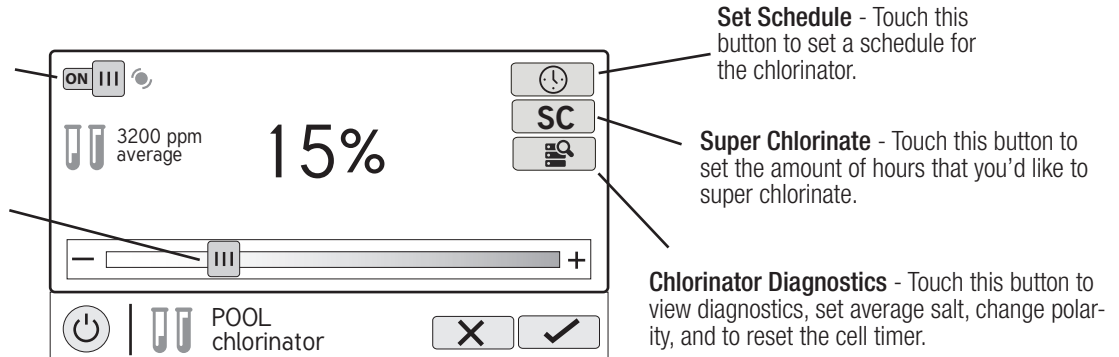

Chlorinator Control Screen

If using an HL-CHEM - The Hayward HL-CHEM Sense and Dispense accessory continuously tests the pool's sanitization and pH levels allowing the OmniLogic to automatically generate the correct amount of chlorine and dispense the proper amount of pH reducer. If using the HL-CHEM and ORP has been enabled in the Configuration Wizard, the OmniLogic will display chlorinator readings and settings in "mV" rather than "%". Refer to the information below as well as the HL-CHEM manual for configuration and operation instructions.

Chlorinator Setting - The OmniLogic can only generate chlorine while the filter pump is operating. Set the percentage of run time that you desire chlorine generation. Raise this value to generate more chlorine. Lower this value to generate less.

NOTE: After the initial setting, you may need to raise the setting when the pool water temperature increases significantly, when there is higher than normal bather load or when your chlorinator cell ages. You may need to lower the setting when the pool water temperature decreases significantly or there are long periods of inactivity.

Super Chlorinate - When you have an unusually high bather load, a large amount of rain, a cloudy water condition, or any other condition that requires a large amount of chlorine to be introduced to the pool, activate the OmniLogic Super Chlorinate function. The OmniLogic will turn on the filter pump (if not scheduled), set the pool/spa valves to the correct position, and set the chlorine generator to maximum output. The super chlorinate function will continue for the programmed number of hours overriding the normal filter pump schedule settings. At the end of the super chlorinate period, the pool will return to normal operation. If you manually turn off the filter pump, the super chlorinate function terminates.

Chlorinator Diagnostics

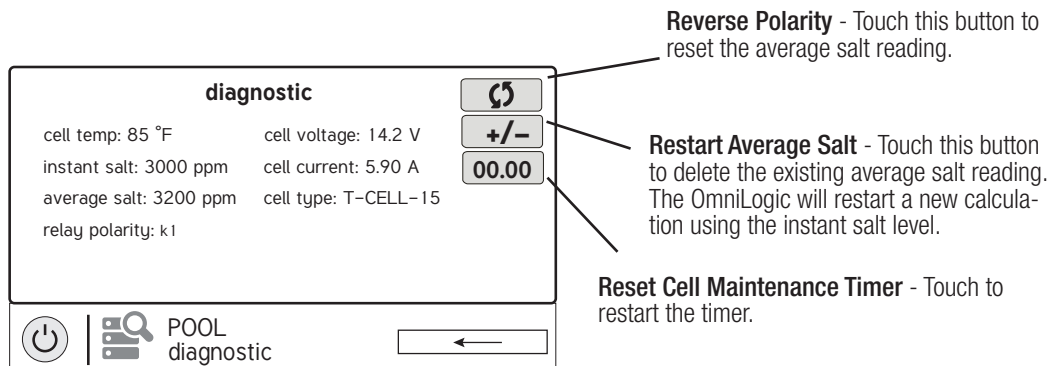
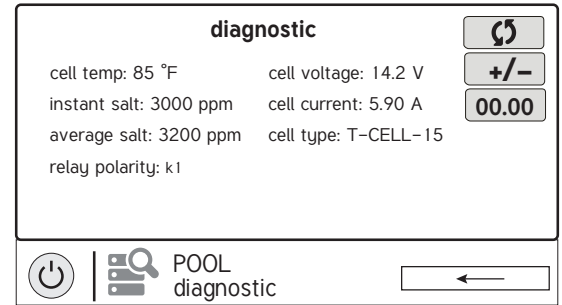
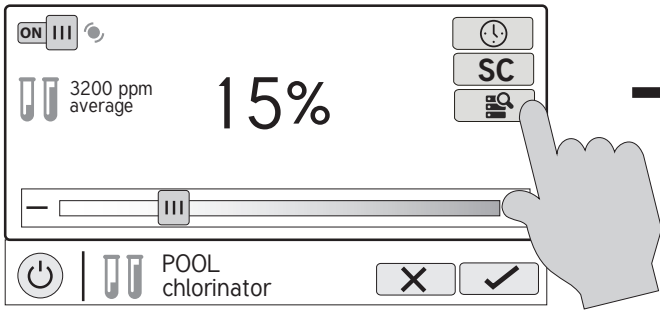

For the chlorinator to be operating, several conditions must exist: the filter pump must be running, the flow switch must detect flow, the chlorinator setting must be greater than 0%, the water temperature at the cell must be between 50°F and 140°F (superchlorinate will run under 50° except during freeze protection), and the salt level must be within the operating range. If any of these conditions are not met, the diagnostic screen will show that the chlorinator is off. Also, depending on the chlorinator setting, the OmniLogic may be in between cycles and the chlorinator is at rest (cell current shows 0.00A). To force the start of the new cycle, you can touch the Reverse Polarity button.

NOTE: If a conventional or solar heater is operating, it is likely that the temperature of the water at the cell is higher than the pool/spa water temperature displayed on the OmniLogic default display.

Restart Average Salt - The OmniLogic monitors salt level while chlorinating. At any time, go to the chlorinator diagnostic screen to view the average salt based on an ongoing calculated average. If you restart average salt, the previous average is deleted and the OmniLogic begins calculating the new average from that moment. The OmniLogic will start with the instant salt reading and calculate an ongoing average.

Reverse Polarity - The OmniLogic periodically reverses the polarity of the voltage applied to the chlorinator cell in order to automatically clean off any calcium deposits. To check operation in both polarities, touch this button. The chlorinator will turn off, wait for 15 seconds and then turn on in the opposite polarity.

Reset Cell Maintenance Timer - To maintain maximum performance, it is recommended that you open and visually inspect the chlorinator cell every 3 months or after cleaning your filter. The OmniLogic will remind you to do this by displaying a message to clean and inspect the cell after approximately 500 hours of operation. You can restart the timer by touching this button.

pH Dispense

If using an HL-CHEM: The Hayward HL-CHEM Sense and Dispense accessory continuously tests the pool's sanitization and pH levels allowing the OmniLogic to automatically generate the correct amount of chlorine and dispense the proper amount of pH reducer. Refer to the information below as well as the HL-CHEM manual for configuration and operation instructions.

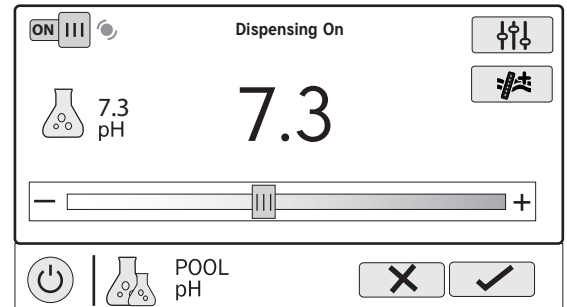
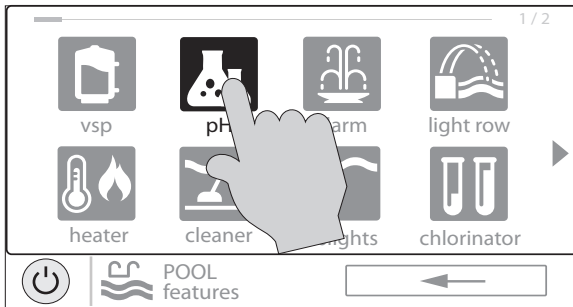

pH Dispense Control Screen

Enable / Disable - Slide this switch to enable and disable the pH dispenser and then touch the Save button.

Set pH Level - Set the desired pH level.

Calibrate - Calibrate the pH reading if the OmniLogic doesn't display the correct level.

Current pH Level - Shows the current pH reading in the pool or spa.

Force 15 minute Run - Touching this button will force the dispenser to run for 15 minutes. This is only available in Service Mode.

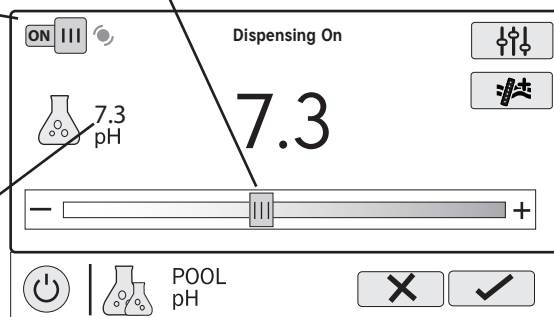

pH Calibration

If the OmniLogic pH reading differs from independent water tests, you can adjust the reading by touching the Calibrate button and using procedure below. You'll be asked for the difference between the displayed pH level and the true pH level. You'll want to select the amount needed to go from the displayed level to the true level. In the example below, the displayed level is 7.3 and the true level is 7.5. You need to add .2 to the displayed level to arrive at the true pH level.

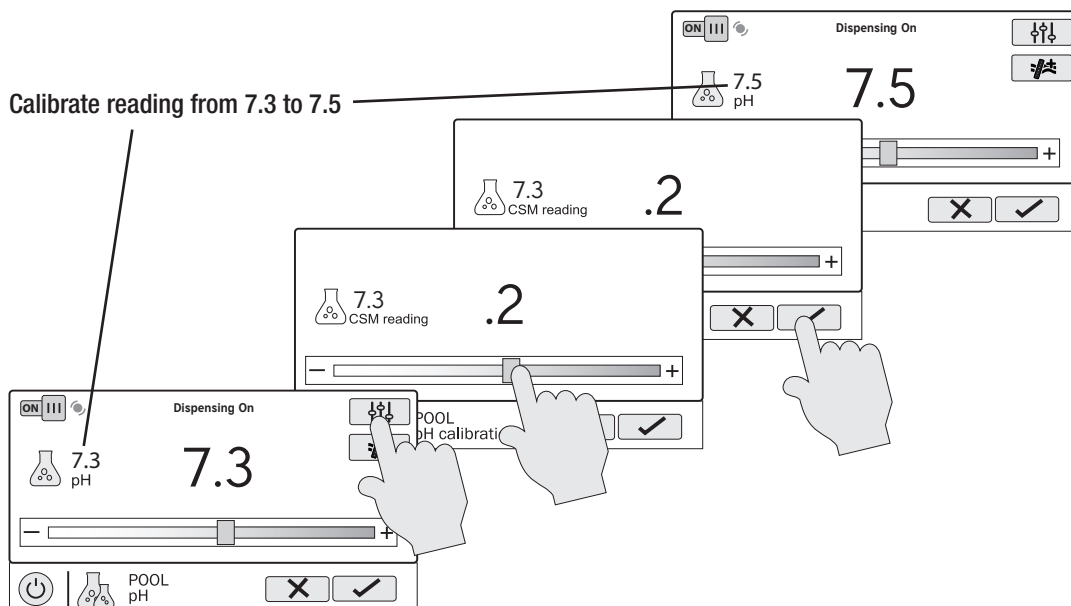

ColorLogic Lights

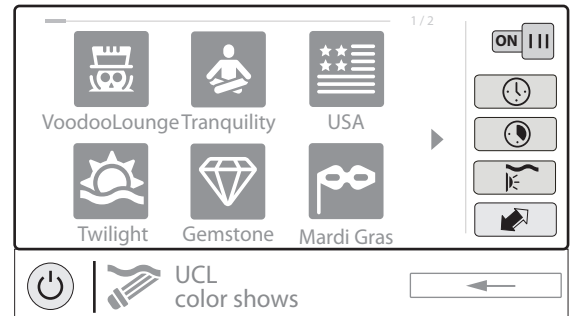
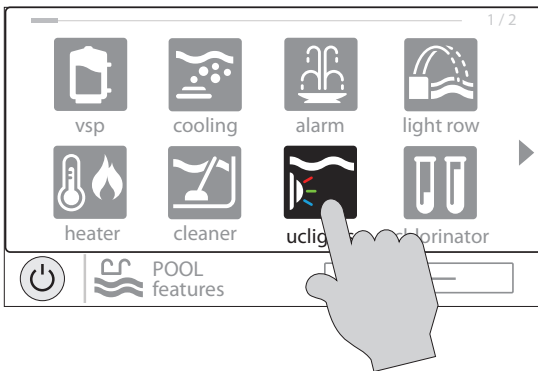

ColorLogic Control Screen

Selections - select the desired light show or solid color.

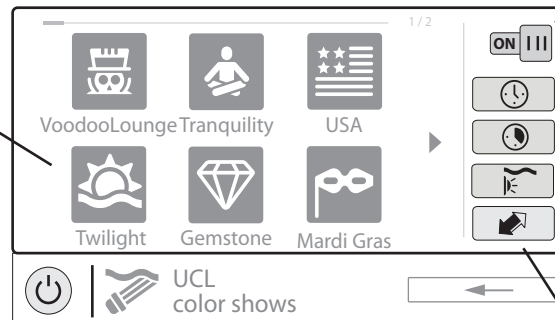

Turn On / Turn Off - Slide this switch to manually turn on/off the ColorLogic lights. This will override schedules or timer settings.

Set Schedule - Touch this button to set a schedule for the ColorLogic lights.

Countdown Timer - Touch this button to set a countdown timer for the lights.

Light Show/Color - This button will change the selection between light shows (🎭) and solid colors (🎨).

Synchronize - Touch this button to synchronize the ColorLogic lights. The ColorLogic lights will then default to Voodoo Lounge.

You can set schedules for the ColorLogic light as well as a countdown timer. This procedure has been shown previously. Note that after the countdown interval, the lights will go off regardless of their previous state.

Light Show/Color - From the ColorLogic Control Screen, select the desired show or color. Use the Advance button to show all of the available selections. Use the Light Show/Color button to switch between all light shows and all solid colors.

Synchronize - Because changing colors and shows requires interrupting power to the ColorLogic lights, there is a chance that the lights could lose synchronization due to timing issues. If you find that the color or show does not correspond with the selection that you've made, the lights may be out of sync. Touch the Synchronize button to re-sync the ColorLogic lights.

Other Lights

You can turn other lights on/off, set schedules, and set a countdown timer at the Other Lights Control Screen shown above. These functions have been illustrated previously in this manual.

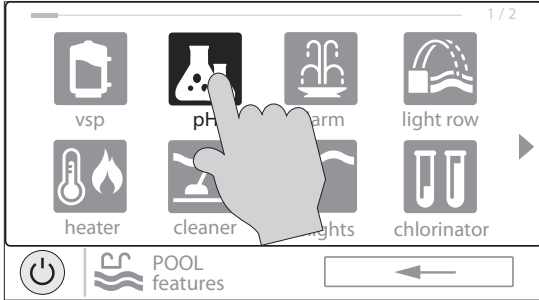

Other Lights Control Screen

Cleaners

You can turn the cleaner on/off, set schedules, and set a countdown timer at the Cleaners Control Screen shown below. You can also set pump speed if a two-speed or variable speed pump has been configured to be used with the cleaner. These functions have been illustrated previously in this manual.

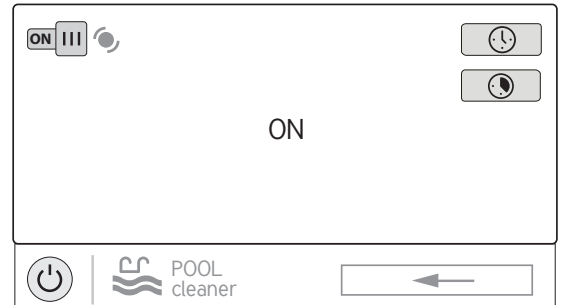
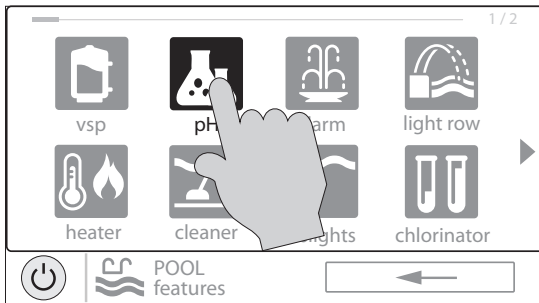

Cleaners Control Screen

Water Features

You can turn the water feature on/off, set schedules, and set a countdown timer at the Water Features Control Screen shown below. You can also set pump speed if a two-speed or variable speed pump has been configured to be used with the water feature. These functions have been illustrated previously in this manual.

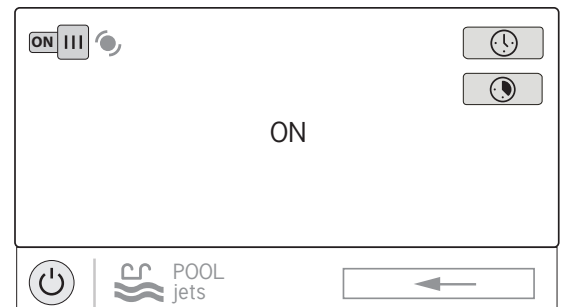
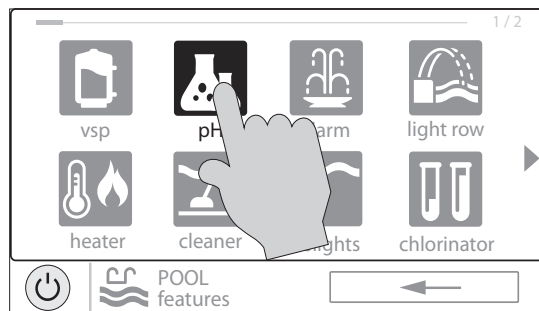

Water Features Control Screen

Accessories

You can turn the accessories on/off, set schedules, and set a countdown timers at the Accessories Control Screen shown below. You can also set pump speed if a two-speed or variable speed pump has been configured to be used with the accessory. These functions have been illustrated previously in this manual.

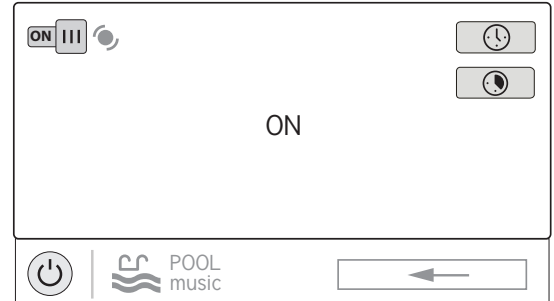
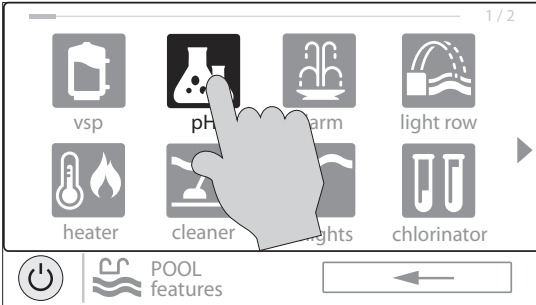

Accessories Control Screen

Schedule

The Schedule button appears in the Features Screen for all Bodies of Water regardless of what equipment has been configured in the Configuration Wizard. It offers a convenient way to create and edit schedules. Any equipment that has been configured for this Body of Water, and has an option for schedules, will be shown in the Schedule Control Screen. Equipment that has been assigned a schedule will show a clock symbol in the upper right side of the button. Touching any of these buttons will bring you to the schedule screen for that equipment. Create and edit schedules as shown on page 8.

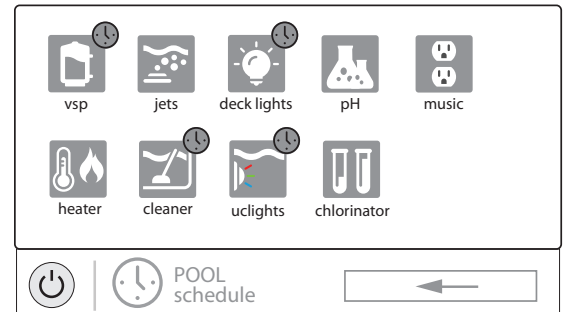
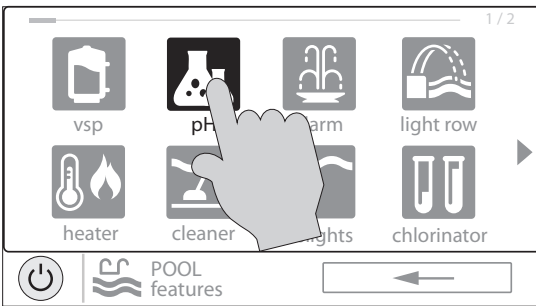

Schedule Control Screen

Spillover

If spillover is configured, you can turn spillover on/off, set schedules, and set a countdown timer at the Spillover Control Screen. These functions have been illustrated previously in this manual.

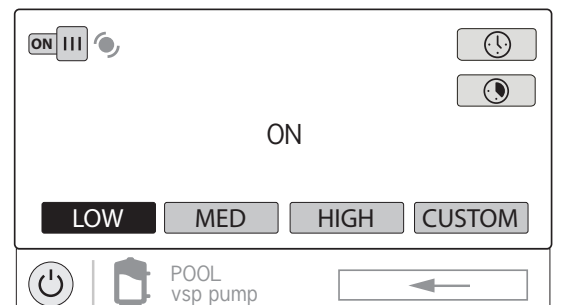
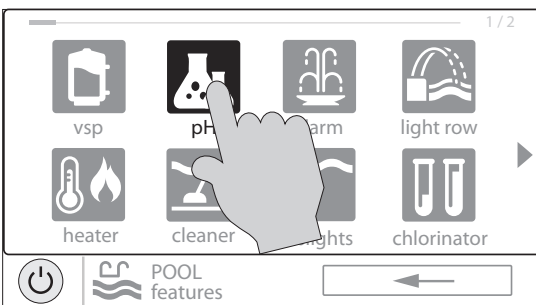

Spillover Control Screen

Freeze Protect Override

If freeze protection is enabled AND the air temperature falls below the freeze threshold, the OmniLogic will turn on the filter pump to circulate the water. If two bodies of water are configured, the valves will also alternate between the pool and spa every 30 minutes and the filter pump will turn off while the valves are turning. The chlorinator will not operate if freeze protection is the only reason the pump is running. Freeze protection can be overridden for 60 minutes by touching the Freeze Prot. button found in the Features Screen for the Body of Water with the highest heating priority (see below). **IMPORTANT:** Ensure that equipment is protected from a freeze condition before overriding this feature. To resume normal freeze protection, simply touch the Freeze Prot. button again.

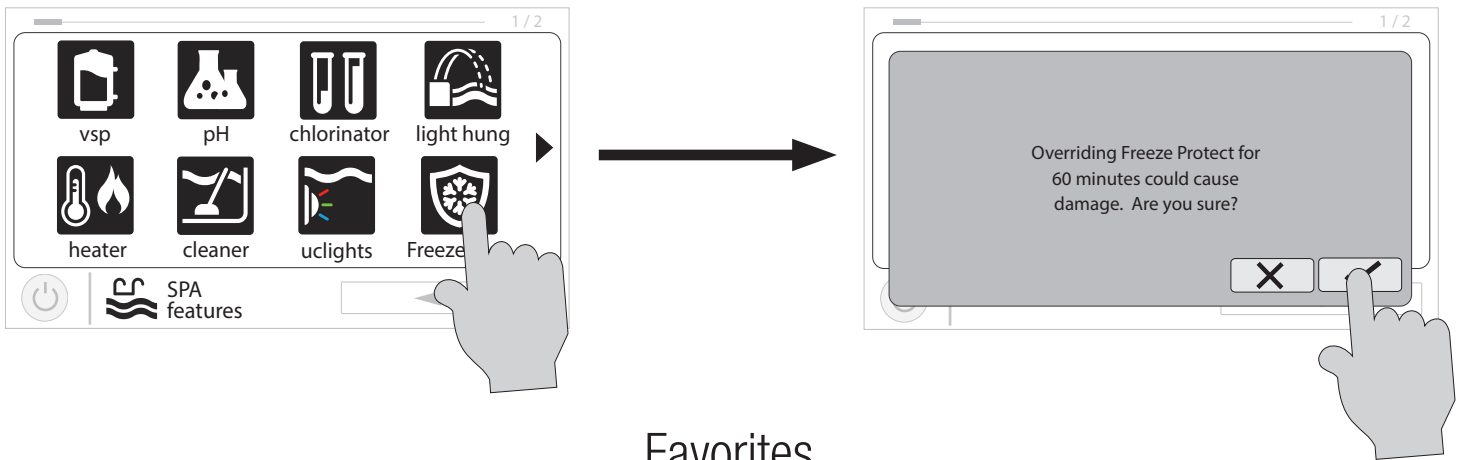

Favorites

Favorites can be found on the right side of the Home Screen and offer control for equipment regardless of which Body of Water is being displayed. Favorites are also used to control equipment that has been configured for the "Backyard". Favorites offer quick easy access to frequently used functions and most Favorites can be added to Simple Mode (page 5).

The OmniLogic will automatically create some Favorites based on your system's configuration. You can also create your own Favorites. Once Favorites have been created, you can change the location in which they appear on the Home Screen. In addition, if you no longer require a Favorite, it can be deleted. The OmniLogic supports up to a total of 50 Favorites.

In most cases, touching a Favorite button on the Home Screen will bring you to the same screens that have been covered in the Control Screens section of this manual. Refer to these screens if necessary.

Alarms

An alarm condition will change the mood color of the entire touchscreen and display a "!" symbol in the upper right side of the associated button as shown:



For more detail, use the Alarm button found in Favorites. Alarms are automatically generated when the OmniLogic detects a condition outside of the normal operating parameters. The Alarm button found in Favorites will bring you to a screen that displays any active alarms. Some alarms can be manually deleted; others will remain until the alarm condition is corrected.

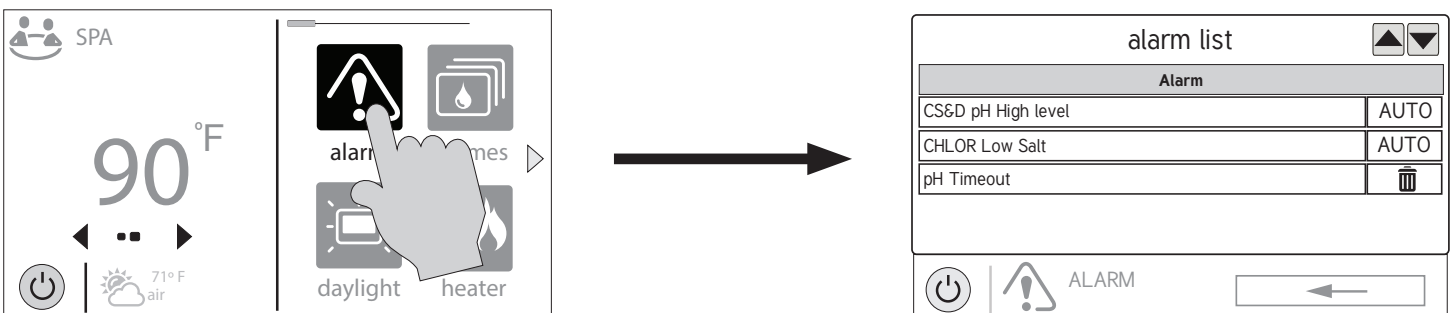

Home Screen

Deleting Alarms

For Alarms that can be manually deleted, follow the procedure below.

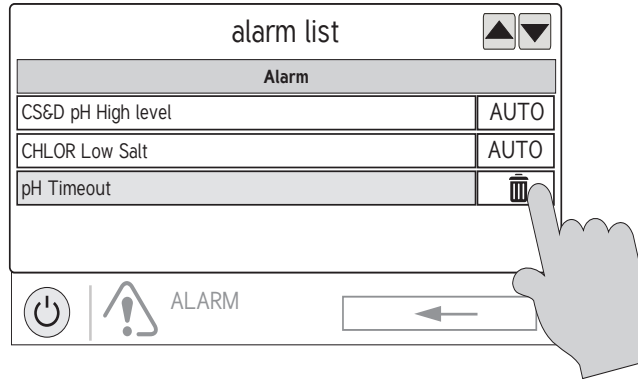

Daylight

Daylight is another button that will appear in Favorites by default. This button is used to change the screen contrast for better viewing in bright sunshine. Touching this button will toggle Daylight viewing on and off.

Features/Lights/Heaters/Backyard

These four buttons function similarly. If any water feature, light, heater or backyard accessory has been configured in the Configuration Wizard, a Features, Lights, Heaters and/or Backyard button will appear in Favorites. These buttons give you quick access to the Control Screens for all related pool equipment. These are the same Control Screens that you've used in the Body of Water Features and Controls Screen section of this manual. For Features, Lights and Heaters you can display the equipment based on a particular Body of Water or from all Bodies of Water as shown below.

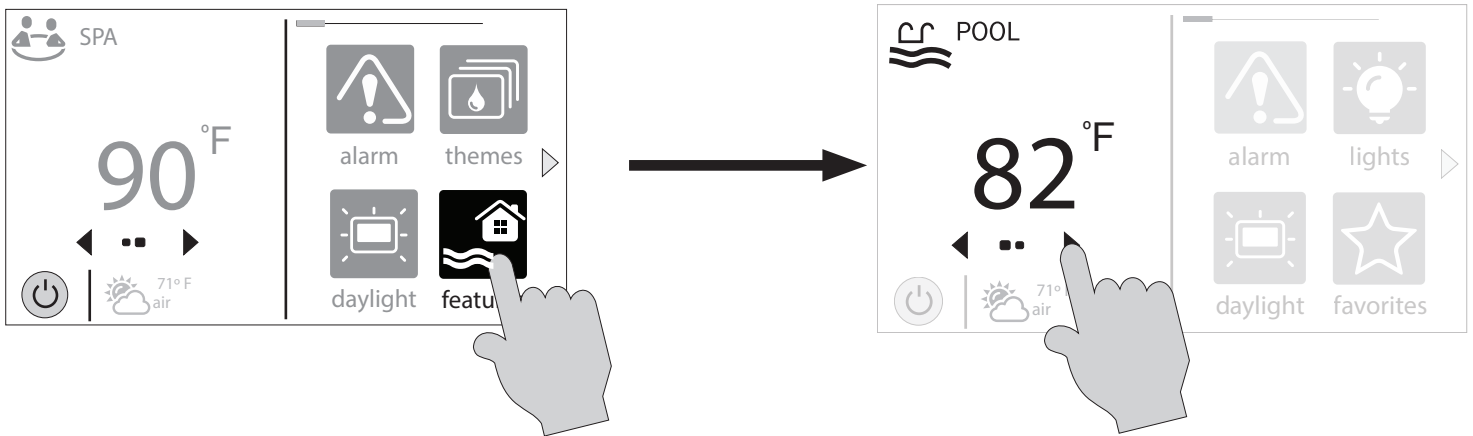

Edit Features/Lights/Heaters

When a feature, light or backyard accessory is selected, you'll advance to the related Control Screen.

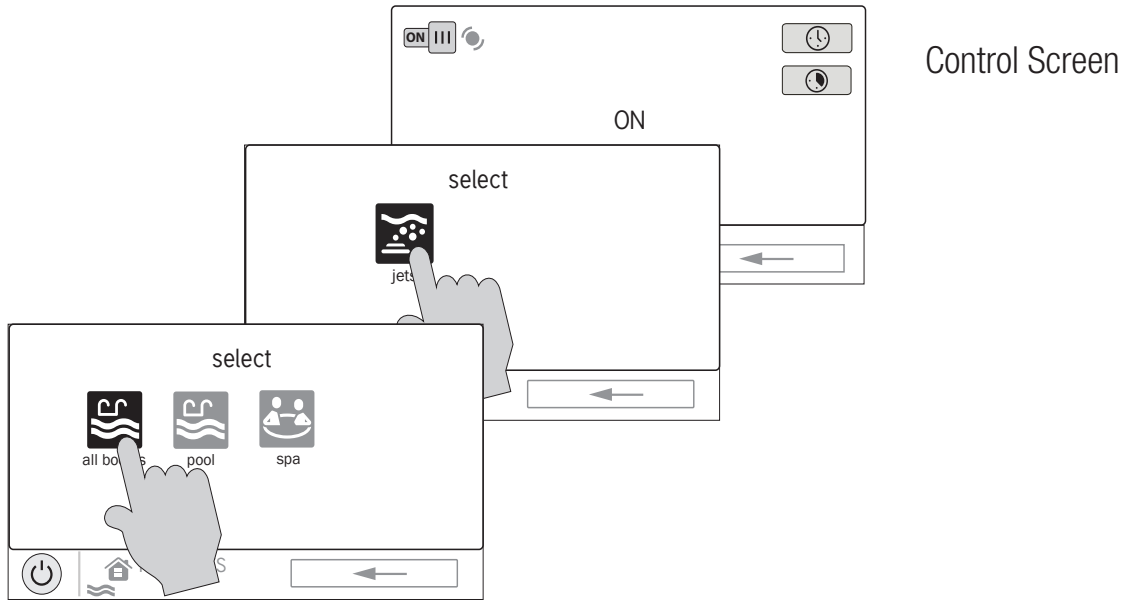

Favorites Screen

All of the buttons on the right side of the Home Screen are referred to as "Favorites" but there is also a Favorites button. Using this button, you can create and manage all of your Favorites.

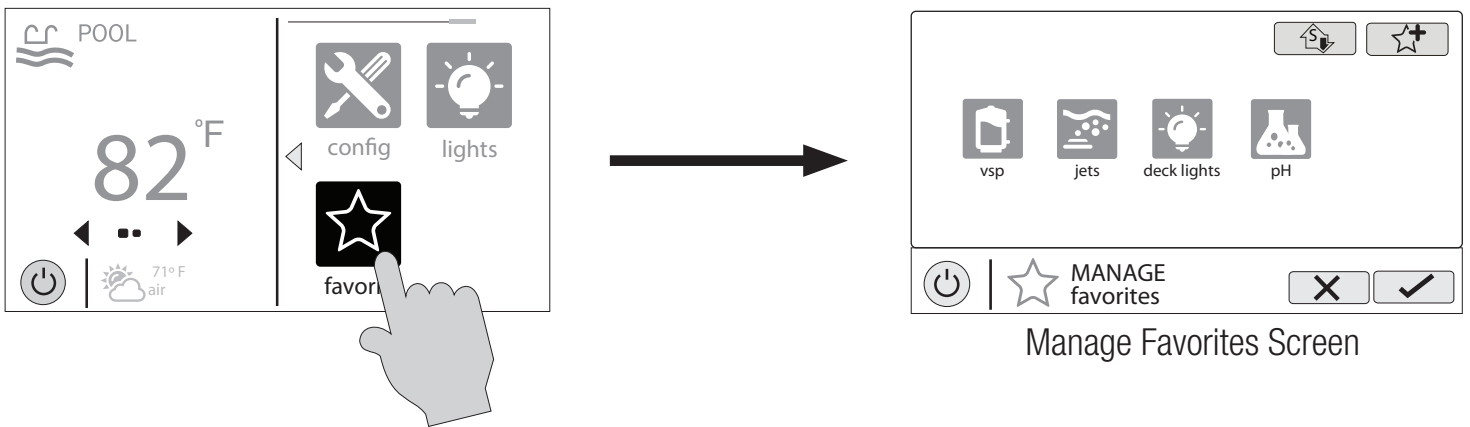

Add to Simple Mode - Touch this button to add a favorite to Simple Mode.

Add Favorite - Touch this button to add a favorite.

Current Favorites - These are favorites that have already been added. You can change the location of where they appear on the Home Screen.

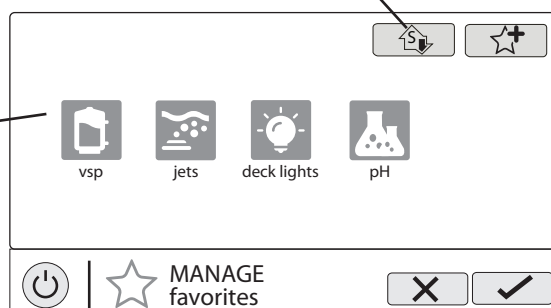

Creating Favorites

Follow the procedure below for adding Favorites. This example shows how to create a Favorite for equipment that was configured as a Backyard Accessory. In this case, "Music". To find "Music" in our Add Favorites screen, we have to select "Backyard" when prompted. The next screen will show all equipment configured for the Backyard; in this case, just Music. Selecting Music and saving will add Music to the Favorites screen. We can now move the Music button if desired.

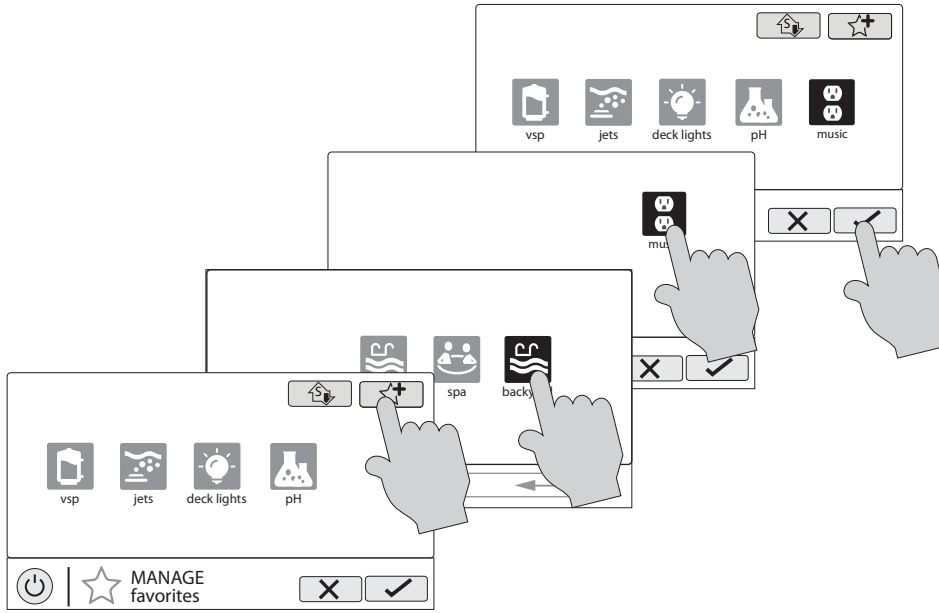

Moving Favorites

Favorites will be displayed on the Home Screen in the order that they are shown on the Favorites Screen, from left to right. The default Favorites can not be moved. To move Favorites, follow the procedure below.

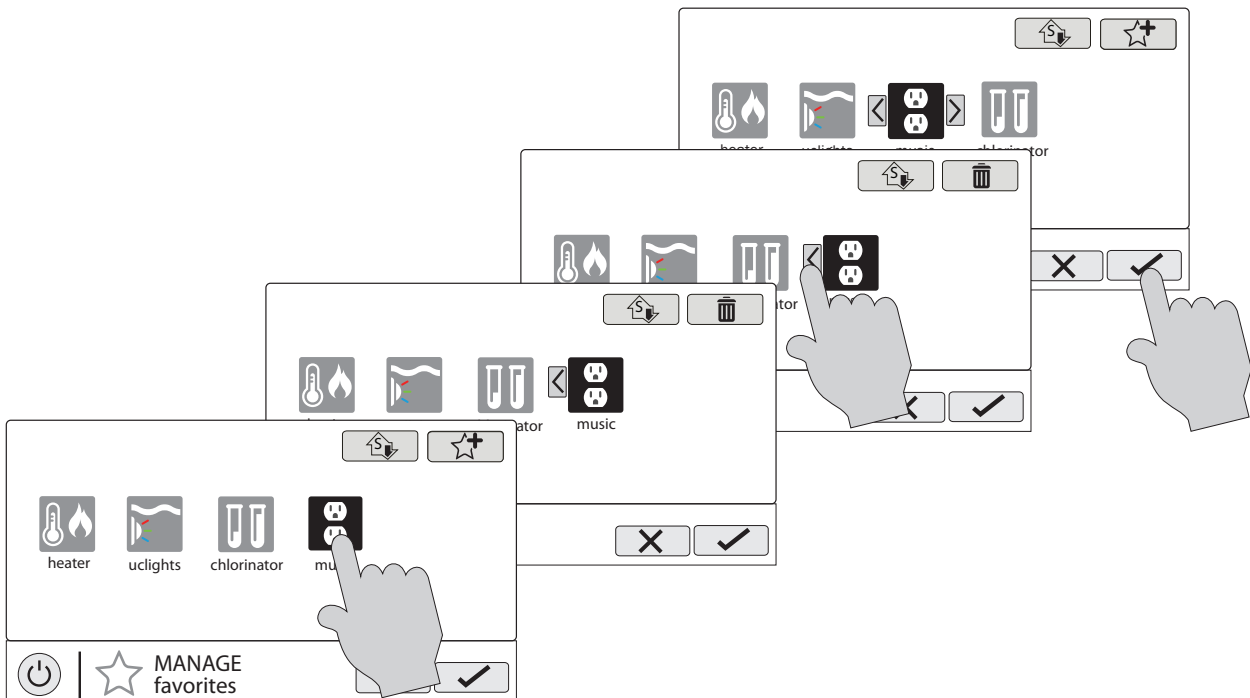

Deleting Favorites

To delete Favorites, follow the procedure below. Default Favorites can not be deleted.

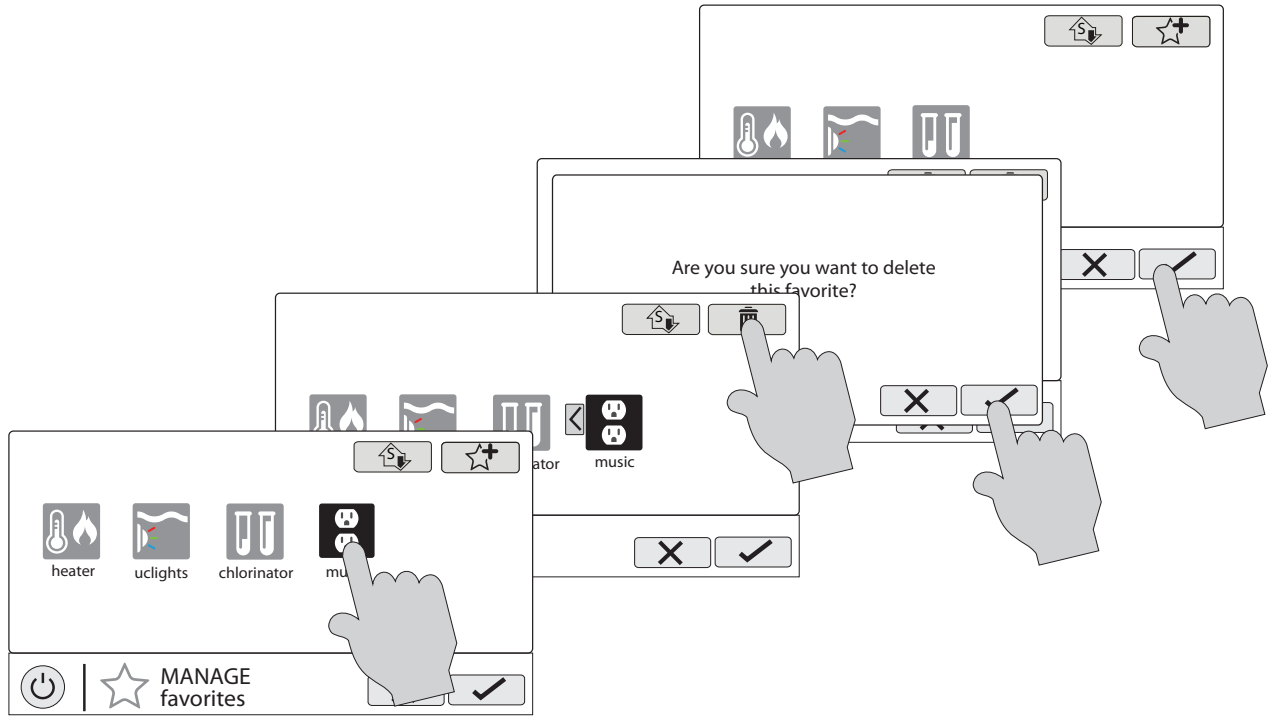

Adding Favorites to Simple Mode

For more information on Simple Mode, refer to page 33. Note that most Favorites can be added to Simple Mode but not all. Follow the procedure below. Note: If the Favorite has been added to Simple Mode, moving the button location on the Favorites screen will affect its position on the Simple Mode screen.

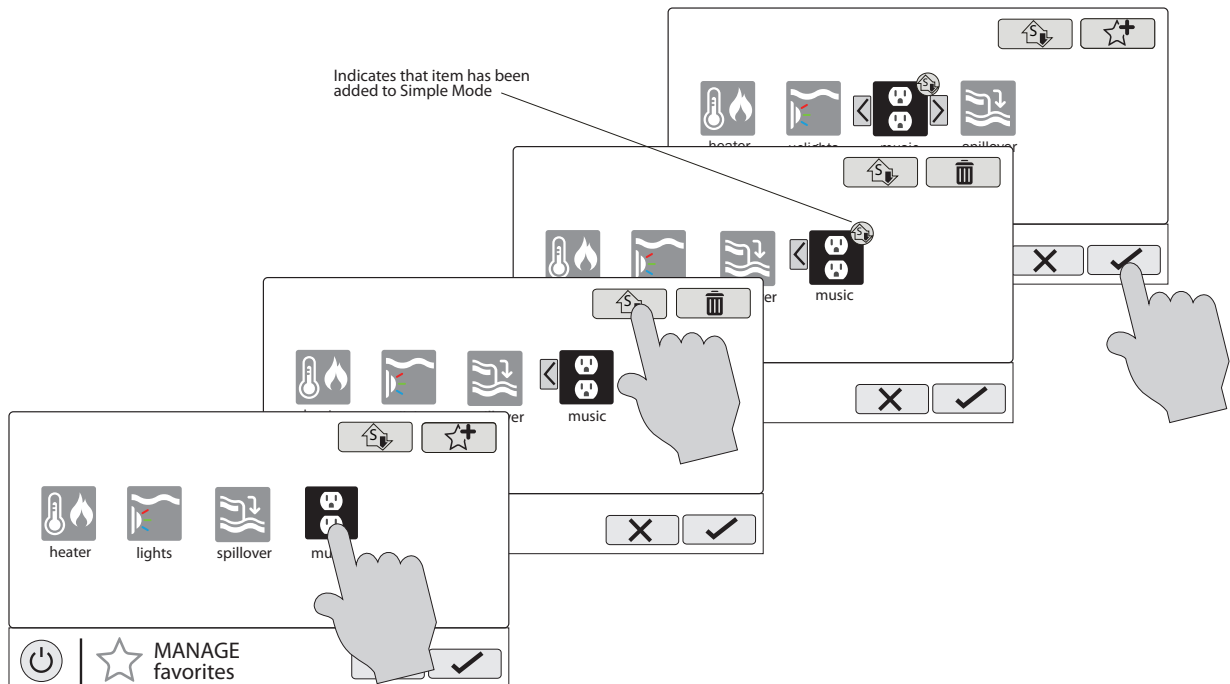

Deleting Favorites from Simple Mode

Deleting Favorites from Simple Mode is similar to adding Favorites to Simple Mode.

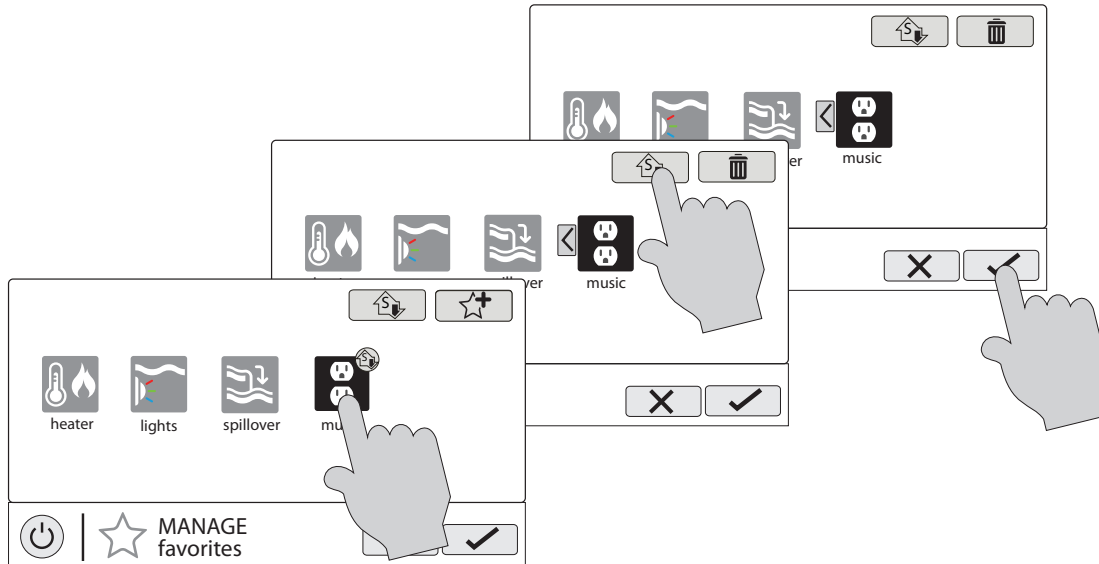

Themes

Themes allow you to execute many pool functions with just one button. This can be handy for functions that require interaction with various pool equipment. For example, spending an evening in the spa might require you to turn on the spa jets, set the spa heater to 104°, turn on music and turn on the spa lighting. Rather than manually performing these functions, they can be saved as a theme and executed with just one button. To create a Theme, put all of the pool/spa/backyard equipment into the desired state. In the example above, you would set all the equipment as described. When creating Themes, the OmniLogic takes a “snapshot” of the system state/settings. This snapshot is saved as a Theme. Refer to the following diagrams and information for creating and running Themes.

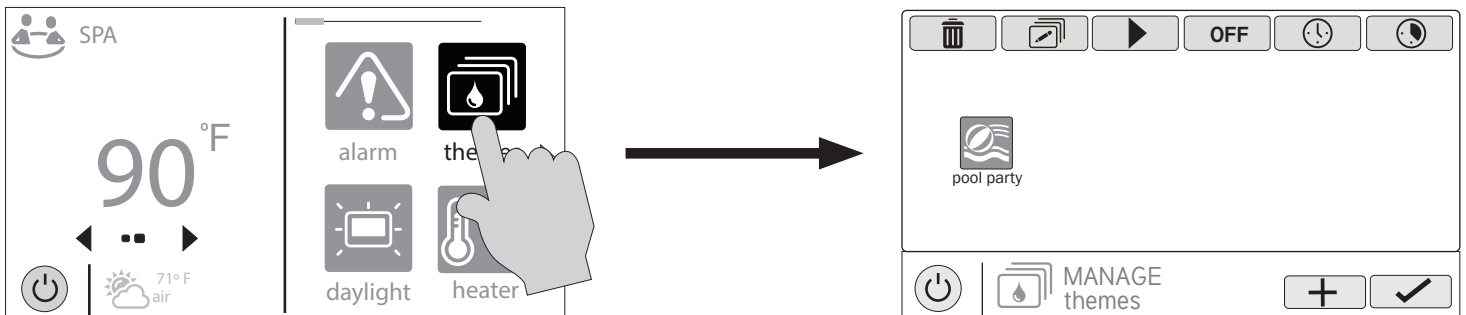

Manage Themes Screen

Edit Theme - After selecting a Theme, touch this button to edit the Theme. You can rename, change icon and set as favorite.

Start Theme - After selecting a Theme, touch this button to start the Theme.

End Theme - After selecting a Theme, touch this button to end the Theme.

Select Theme - Touch this button to select the desired Theme. You can now turn it on/off, edit, set a schedule, set a countdown timer, or delete the selection using the buttons above.

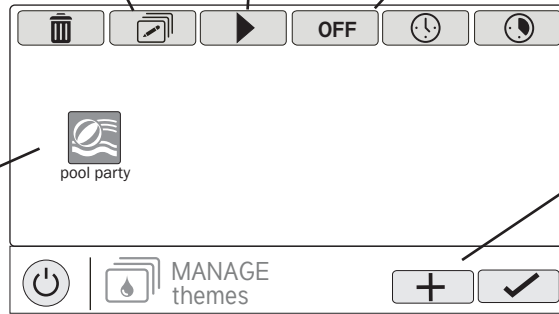

Create a Theme - Touch this button to create a Theme. Before creating, make sure all pool/spa/backyard equipment is in the desired state.

Create a Theme

To create a Theme, put all of the pool/spa/backyard equipment into the desired state.

Select an Icon - Touching this button will bring you to an icon selection screen. Touch the advance button to access more icons. Selecting and saving the icon will bring you back to this screen.

Name the Theme - Touching this button will bring you to a keyboard where you can enter a name for the Theme. Saving the name will bring you back to this screen.

Add the Theme to Favorites - Touching this button will toggle the selection from Yes to No. Select whether you want the new Theme to be added to Favorites. If so, a new button will be generated and added to Favorites. You'll be able to turn the Theme on/off with the new Favorites button.

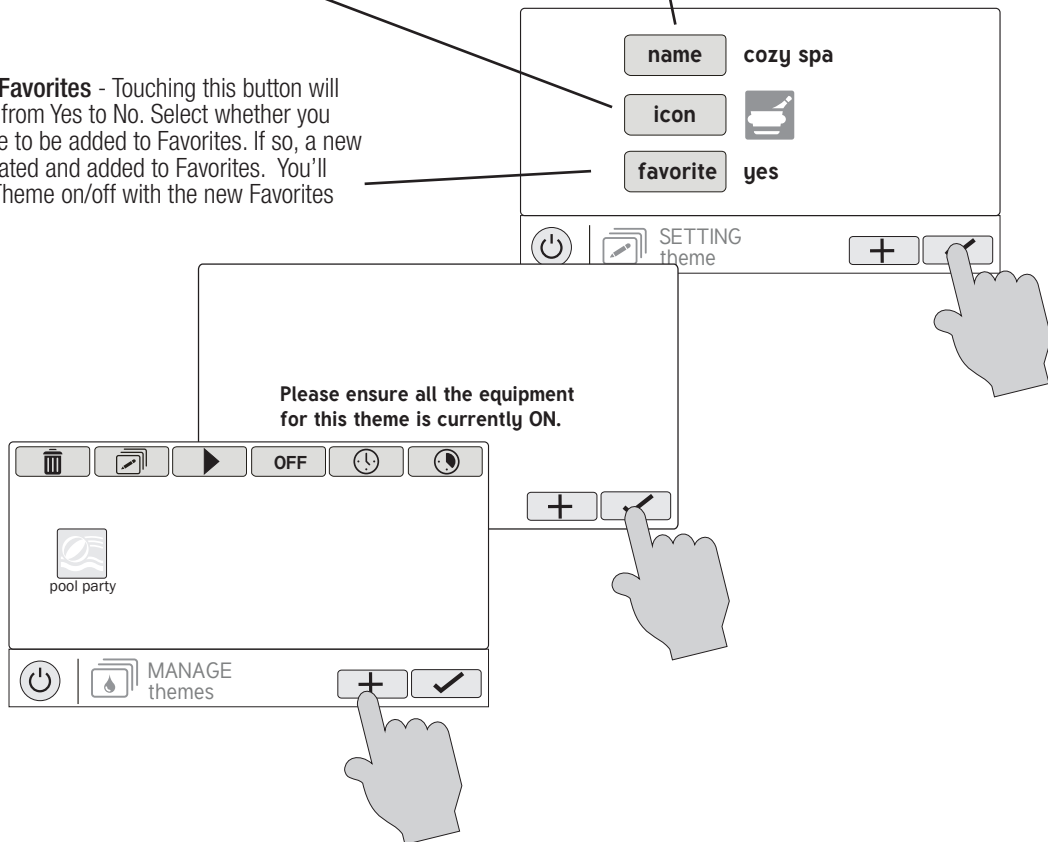

Starting a Theme

If a Favorite was created for the Theme, run the Theme just as you would any other Favorite. To start a Theme within the “Manage Themes” screen follow the procedure below. Note that only one Theme can run at a time.

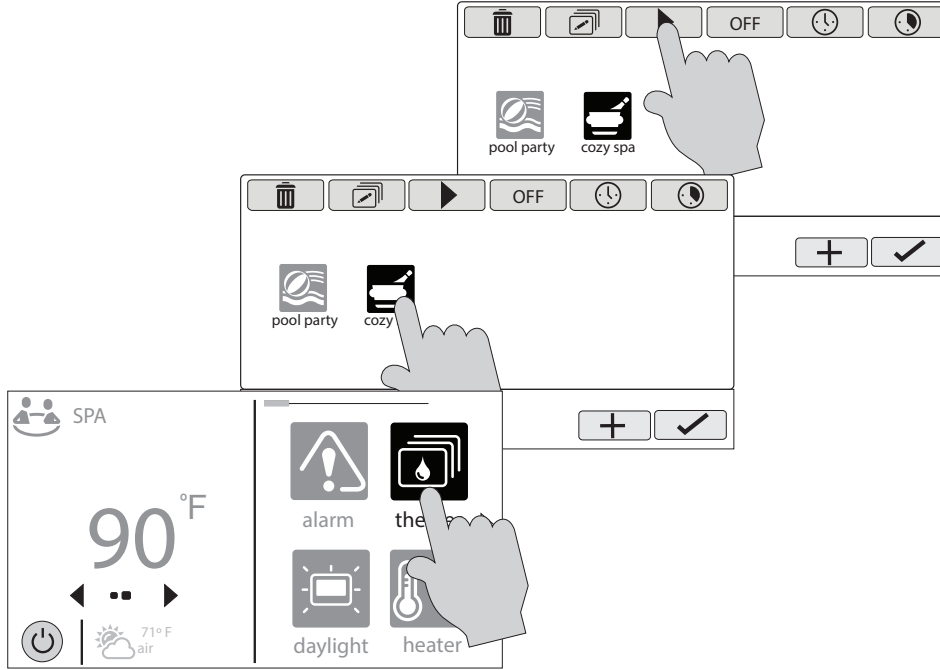

Stopping a Theme

If a Favorite was created for the Theme, stop the Theme just as you would any other Favorite. To stop a Theme within the “Manage Themes” screen follow the procedure below. Note that when stopping a theme, all functions will turn off and the filter pump will return to any schedules that have been previously set.

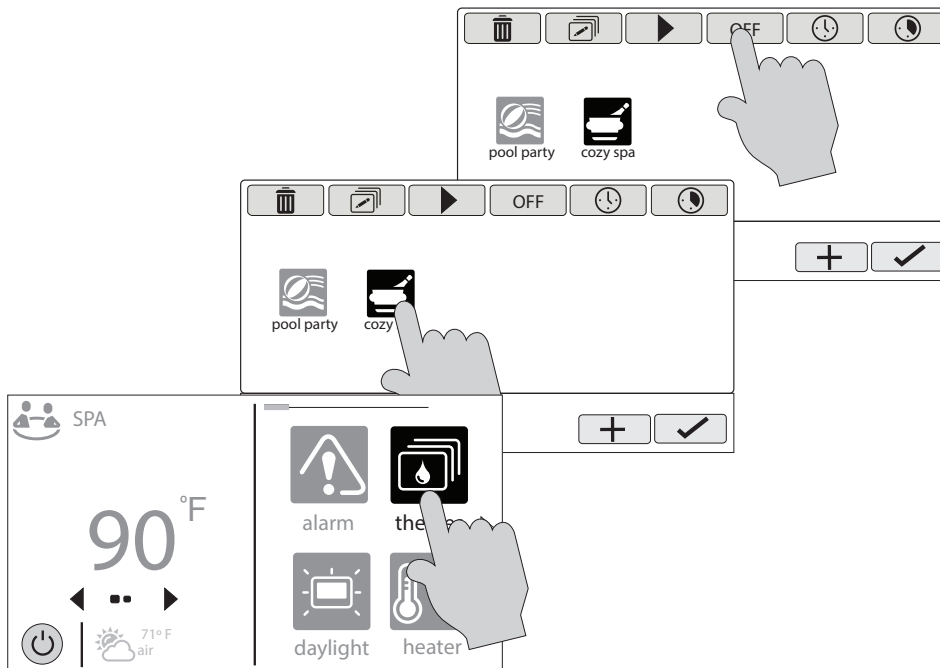

Config

The Config button offers many options related to the configuration and operation of the OmniLogic. You can view log files, backup configuration settings, restore configuration settings, modify display settings and more.

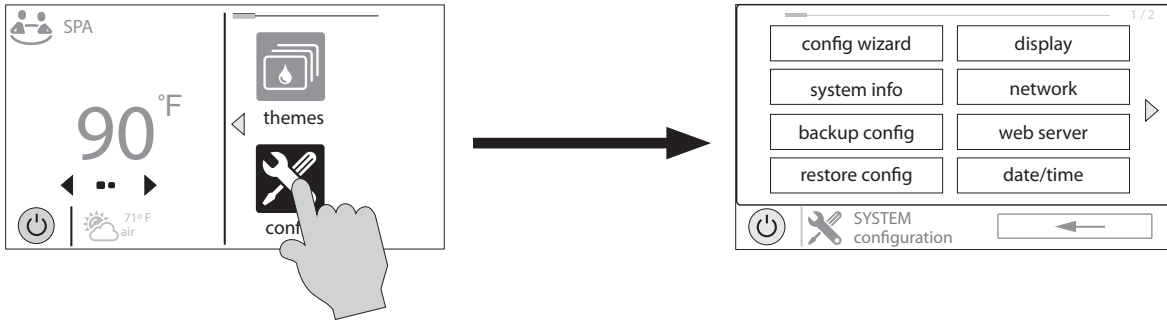

Using a USB Thumb Drive

Some options require the use of a USB thumb drive (removable media) that will be inserted in the OmniLogic. If logging is desired (page 29), the thumb drive should be left in the OmniLogic during normal operation. The location of the USB port is shown in the Installation Manual. If a thumb drive will be used, follow the procedure below when inserting and removing.

WARNING - The deadfront must not be removed when the OmniLogic's subpanel is powered. The thumb drive will always be inserted and removed with the power off.

1. Turn off all pool equipment.
2. Remove power to the OmniLogic's electrical panel.
3. Remove the OmniLogic deadfront (front panel) to gain access to the local terminal display.
4. On the left side of the local terminal display, locate the USB port and insert the thumb drive.
5. Re-install the deadfront.
6. Apply power to the OmniLogic.
7. After the OmniLogic starts, perform the procedure which requires the thumb drive.
8. When procedure is finished, remove power to the OmniLogic.
9. Remove the OmniLogic deadfront.
10. Remove the thumb drive.
11. Re-install the deadfront.
12. Apply power to the OmniLogic and resume operation.

Config Wizard

The Configuration Wizard is used to add, remove and configure pool equipment that is controlled by the OmniLogic. This has already been done at installation and should not be needed unless a change has been made to the system. If a new configuration is saved, it will overwrite the old configuration and may require you to change previous equipment settings.

If pool equipment is added or removed from your system you may edit the existing Configuration. Two types of editing are available; Full Edit and Quick Edit. A Full Edit will walk you through each step of the Configuration Wizard and allow you to save at the end. Refer to the Configuration Wizard Guide in the Installation Manual when using a Full Edit. A Quick Edit allows you to go directly to the equipment that you'd like to add/remove/configure. In most cases, Quick Edit will offer the most convenient way to make these changes. For more information, refer to the Quick Edit Guide section in the Installation Manual.

System Info

System Info will show the Hayward Unique Address (HUA) and version for all smart components (components that communicate with the OmniLogic). This may be needed by Hayward Technical Service when troubleshooting or diagnosing system issues.

Backup Config

You can back up your configuration settings, schedules, setpoints etc. to the OmniLogic's internal memory or to a USB thumb drive. If using a thumb drive, use the instructions for inserting and removing thumb drives on page 27.

Restore Config

You can overwrite the existing configuration with a backup that is stored internally or on a thumb drive. You will get the following options when selecting Restore Config:

Restore Last - this is the last backup that was saved to internal memory.

Restore Prev - this is the second to last backup that was saved to internal memory.

[DATE] - this is the oldest backup that was saved to internal memory. The date will be shown on the selection.

Restore from USB - you can browse the USB drive and find available backups. Backup files will begin with "MSPCONFIGxyyzz" where xx=month, yy=day, zz=year (the date the file was created). The OmniLogic will automatically create a backup file when a new configuration is saved. These files end with ".xml". Backup files that are created manually end with ".bak" Both types can be restored.

To restore a backup, make your selection from above and then touch Save.

Display

The Display Settings screen offers options to customize the way the OmniLogic displays information.

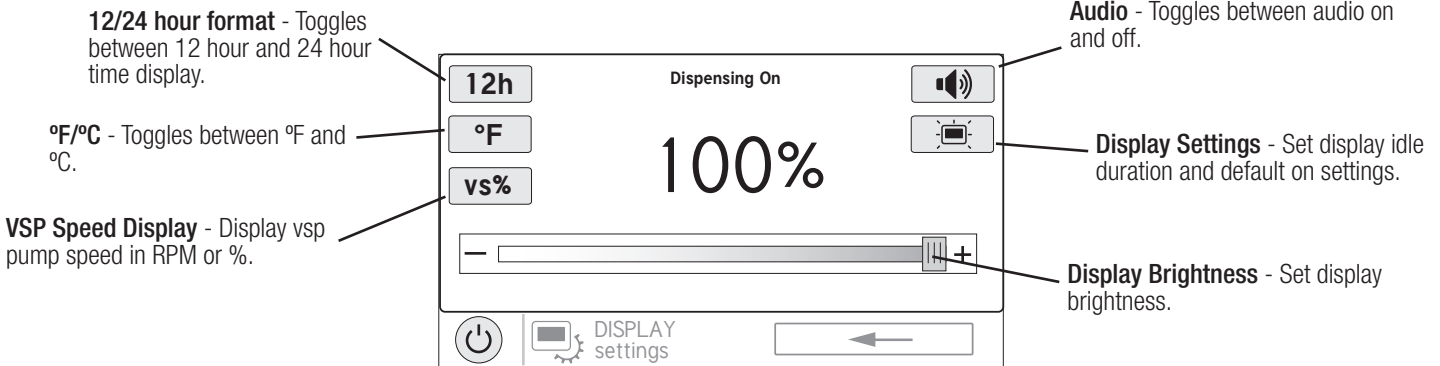
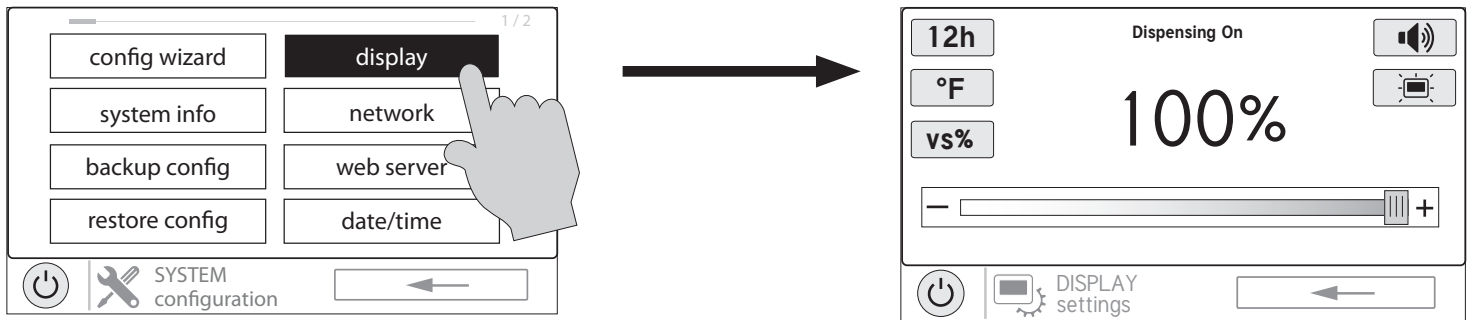

Network

You can view the OmniLogic ip address at this screen. This is the address that the router will use to connect the OmniLogic to the home network. You can also turn the connection to the router on and off using the On/Off toggle.

Web Server

The OmniLogic connects to Hayward servers to enable remote control through the web using computers and mobile devices. This screen will display the ip address of this connection to the server. You can also turn the connection on and off using the On/Off toggle.

Date/Time

Set the date and time on this screen.

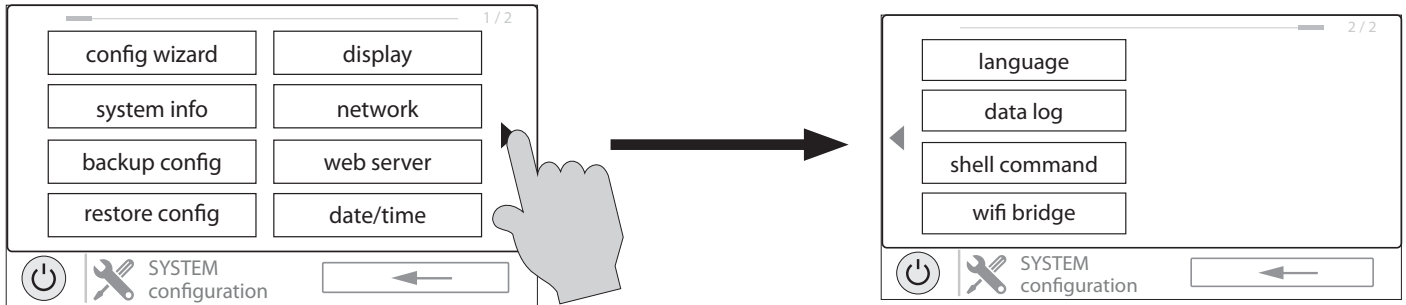

Language

Select a language. If a desired language is not shown, it may be available from Hayward through their website at www.hayward.com/firmware. Refer to page 31 for information on installing new languages.

Data Log (requires Thumb Drive, page 27)

Use this feature if instructed by Hayward Technical Service. The data log shows a log of daily operation and can help Hayward Technical Service diagnose or troubleshoot problems. The Data Log options are:

Clear Log File- this will delete all data in the log file.

Show Log File - this will display the log file.

Restore Defaults - this will return the data log settings to the factory default.

Set Level - you can change the amount of detail that is shown in the log file with this button.

You can also enable and disable data logging using the On/Off toggle.

Shell Command

This screen is reserved for trained service personnel only.

Wifi Bridge

Use Wifi Bridge if adding a HLWLAN wireless transceiver to the OmniLogic or making changes to the wireless connection of a HLWLAN that is already installed. Refer to the HLWLAN for detailed instructions.

Upgrade

Additional functions, features and languages may be available for your OmniLogic.

Determine if Firmware Upgrade is Available

The OmniLogic's firmware is the basic operating system that runs the unit. The OmniLogic was shipped with the version of firmware that was available at the time of release. There may be a newer version available and if so, we encourage you to upgrade. Also, if you have experienced problems, Hayward Technical Support may advise you to upgrade your OmniLogic firmware. If this is the case, follow the instructions below.

1. Determine your current MSP firmware version.

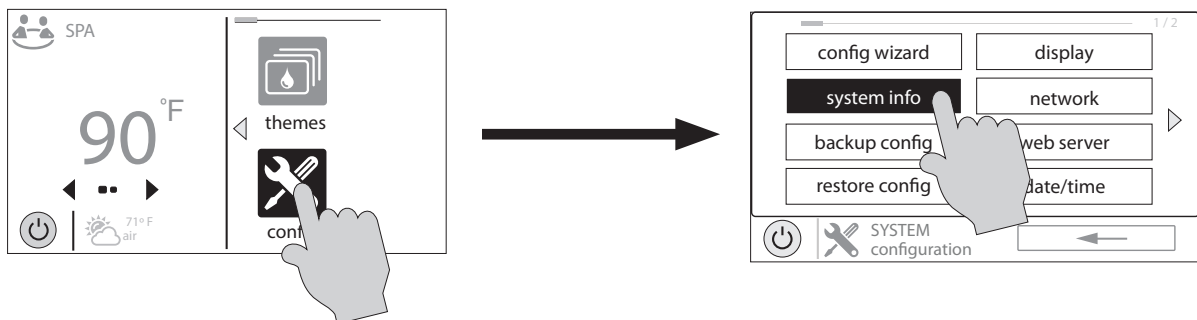

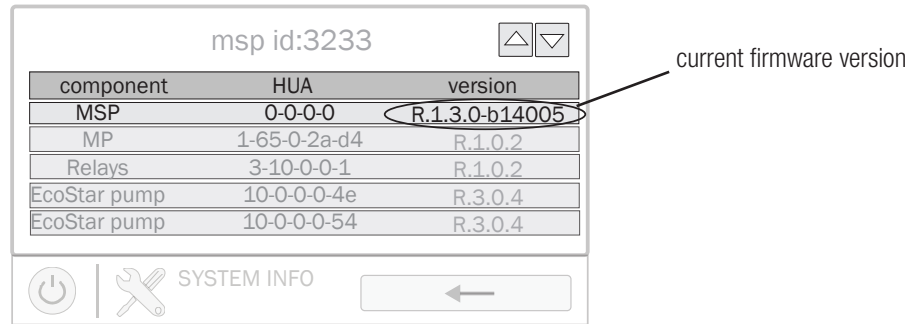

- Using an ordinary web browser, go to www.hayward.com/firmware and compare the latest available version on the web to the current firmware version. If the firmware version on the web is greater (number is larger) than your current version, upgrade your OmniLogic. If not, periodically check the website and upgrade as newer firmware is released.

Upgrading Firmware (must be in Service Mode, page 5)

- Insert your USB thumb drive into your computer.
- Go to www.hayward.com/firmware.
- Click on the link to download the latest firmware and save to the USB thumb drive.
- Turn off all pool equipment.
- Remove power to the OmniLogic's electrical panel.

WARNING - The OmniLogic deadfront must not be removed when the OmniLogic's subpanel is powered. The thumb drive will always be inserted and removed with the power off.

- Remove the OmniLogic deadfront (front panel) to gain access to the local terminal display.
- On the left side of the local terminal display, locate the USB port and insert the thumb drive.
- Re-install the deadfront.
- Apply power to the OmniLogic and allow enough time for the OmniLogic to fully start.
- Enter Service Mode (page 5).
- Touch the Upgrade button.

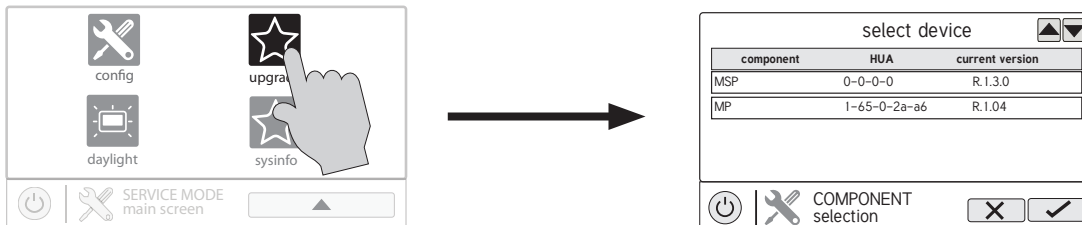

- Select "MSP" and touch the Save button.

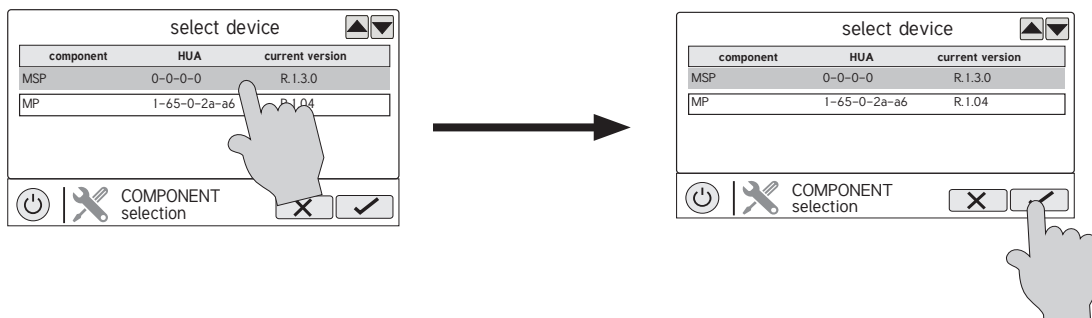

13. The OmniLogic will now look at your USB thumb drive. Select the firmware file that was saved from the website and then touch the Save button.

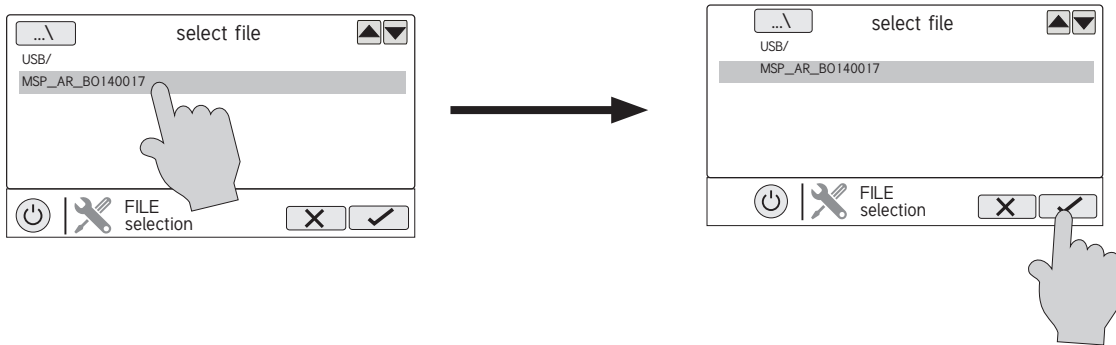

14. Touch Save to begin upgrade. After the upgrade is finished, touch Save to restart.

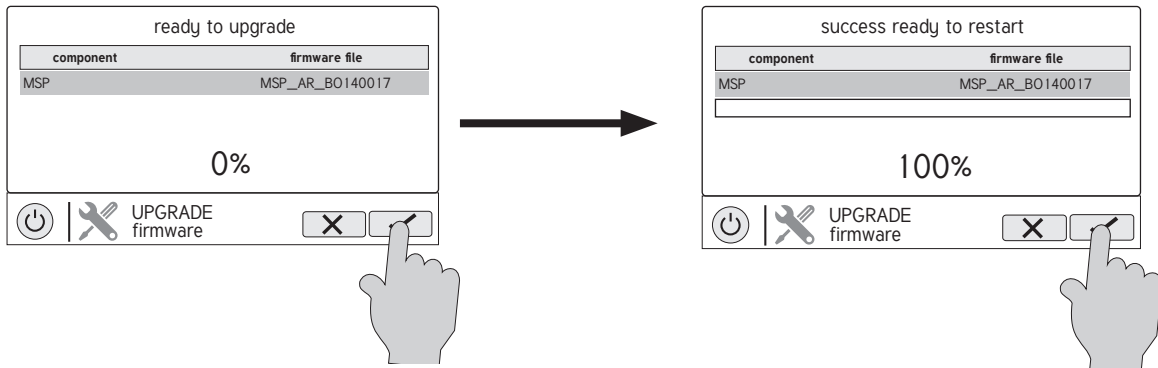

15. After the OmniLogic has fully started (wait 2 minutes to ensure that the unit is done starting), remove power to the OmniLogic.
16. Remove the deadfront.
17. Remove the thumb drive.
18. Re-install the deadfront.
19. Apply power to the OmniLogic and resume operation.

Installing a New Language (must be in Service Mode, page 5)

1. Insert your USB thumb drive into your computer.
2. Go to www.hayward.com/firmware.
3. Click on the link to download the desired language save to the USB thumb drive.
4. Turn off all pool equipment.
5. Remove power to the OmniLogic's electrical panel.

WARNING - The OmniLogic deadfront must not be removed when the OmniLogic's subpanel is powered. The thumb drive will always be inserted and removed with the power off.

6. Remove the OmniLogic deadfront (front panel) to gain access to the local terminal display.
7. On the left side of the local terminal display, locate the USB port and insert the thumb drive.
8. Re-install the deadfront.
9. Apply power to the OmniLogic and allow enough time for the OmniLogic to fully start.
10. Enter Service Mode (page 5).

11. Touch the Upgrade button.

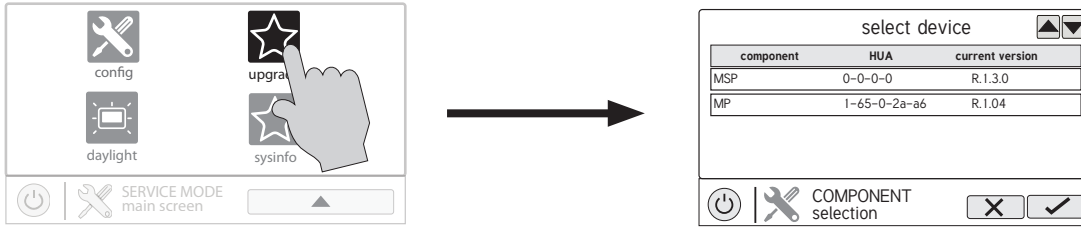

12. Select "MSP and touch the Save button.

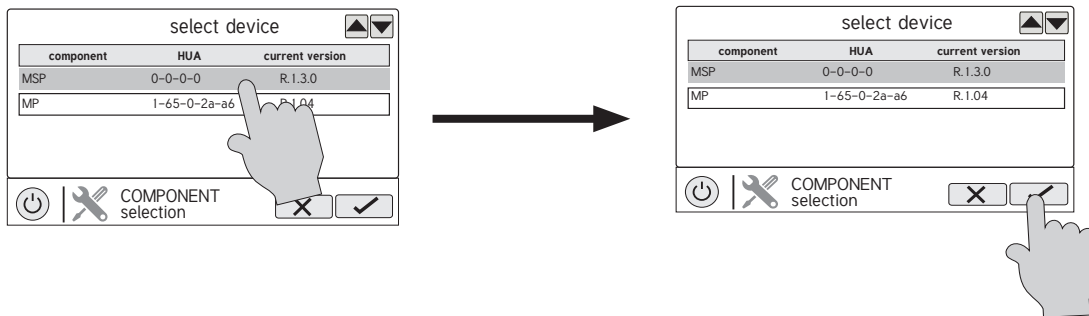

13. The OmniLogic will now look at your USB thumb drive. Select the language file that was saved from the website and then touch the Save button.

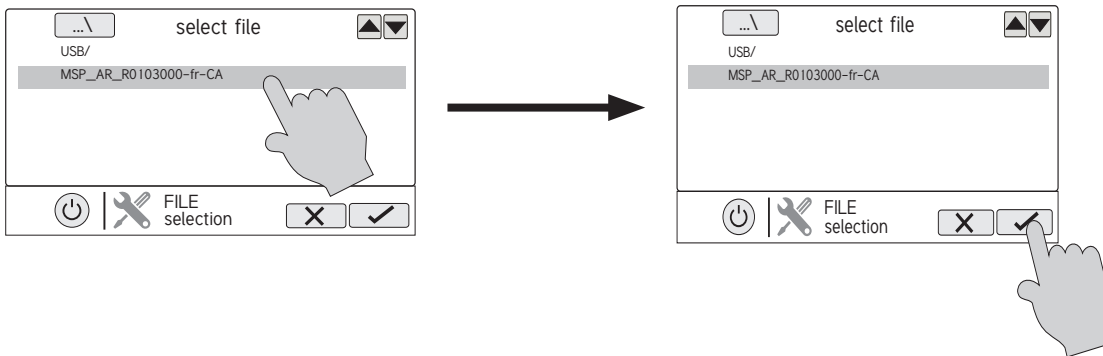

14. Touch Save to begin upgrade. After the upgrade is finished, touch Save.

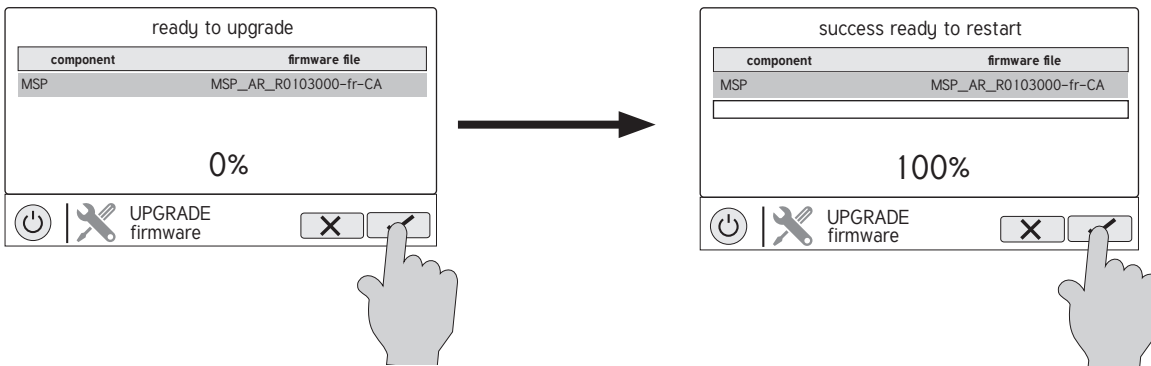

15. Remove the deadfront.
16. Remove the thumb drive.
17. Re-install the deadfront.
18. Apply power to the OmniLogic and resume operation.

Simple Mode

Up to this point, you've been shown how to view the Home Screen and access all of the pool's functions by using Body of Water Features (left side of Home Screen) and Favorites (right side of Home Screen). This method of access is called "Standard Mode" and offers the most information and control. An alternative to Standard Mode is "Simple Mode". Simple Mode eliminates the Home Screen and allows you to view and control only the Favorites that you specify. Simple Mode is customizable and may be preferred to Standard Mode depending on your needs. Simple Mode can provide a convenient way to access the most common functions for owners as well as a handy solution to limit access to other users. Up to 24 Favorites can be displayed in Simple Mode. Depending on the pool equipment that has been configured, some default Favorites may appear in Simple Mode. These default Favorites cannot be removed from Simple Mode. For information on how to add and delete Simple Mode Favorites, refer to the page 23 in manual.

Simple Mode Screen

Schedule Indicator - Favorites that have been configured to operate on a schedule will display this indicator.

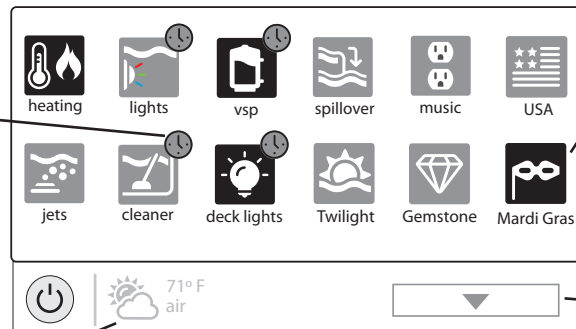

Status - Items that are highlighted are active or "On". In this example, the VSP pump, heater, deck lights and Mardi Gras light show are all On. Touching buttons in Simple Mode will turn the items On or Off.

Home Screen Information - The same information that is displayed on the Home Screen is also displayed on the Simple Mode Screen.

Advance to Next Screen - If more than 12 Favorites are used in Simple Mode, this button will appear. Touch the button to advance to the next screen.

Enter Simple Mode

To enter Simple Mode, go to the Home Screen and follow the procedure below. Entering and exiting Simple Mode will require your OmniLogic's MSP ID number. This number is used as a password. To find your unit's MSP ID, refer to page 35.

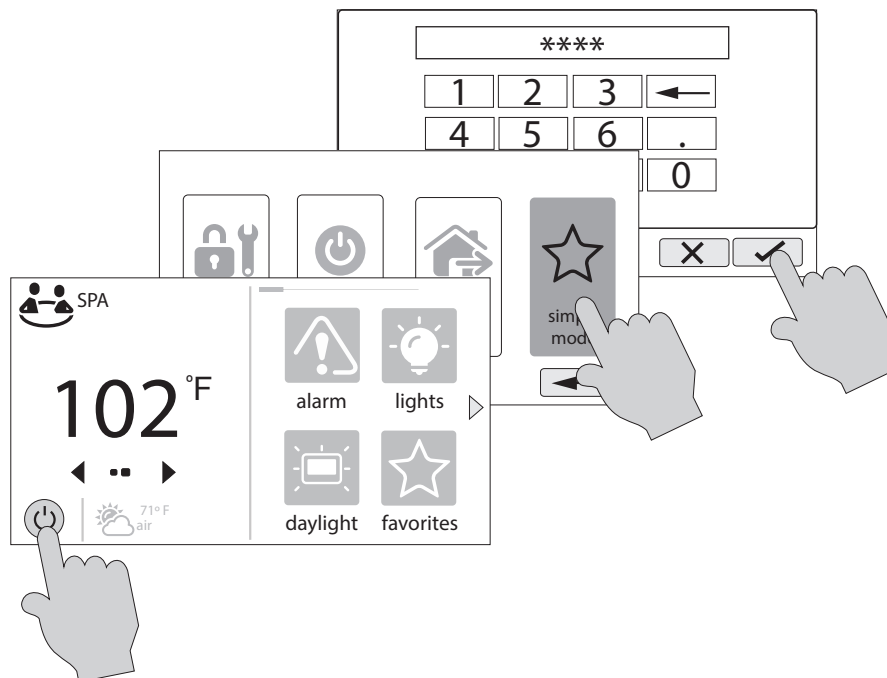

Exit Simple Mode

To exit Simple Mode, follow the procedure below.

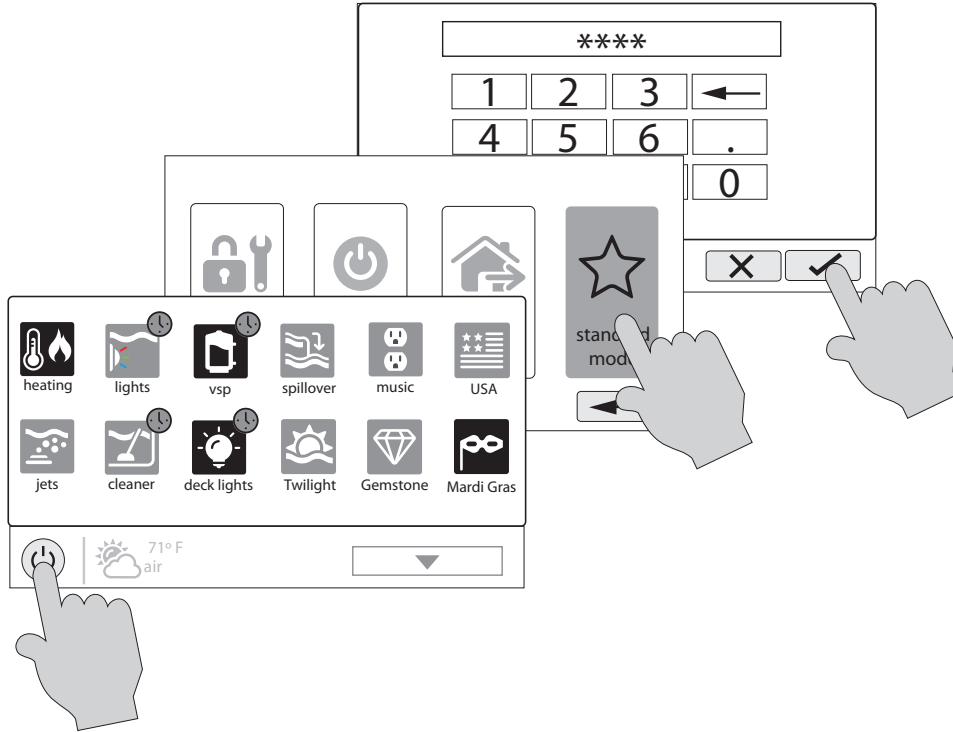



Web Enabled Control

The OmniLogic should have already been configured for use with the home's router to allow for remote control through the web. This procedure is covered in the Configuration Wizard information found in the Installation Manual. After configuration, an account must be created to allow access to the OmniLogic from web enabled devices. If this has not already been done by the installer, follow the procedure below.

- 1) Using an ordinary web browser, go to www.haywardomnilogic.com. If you don't already have an account, select "Register New User" and set up a new account.
- 2) Log in to your account.
- 3) Register your OmniLogic. Registering will require you to answer a series of questions about your OmniLogic. When asked for your Time Zone, be sure to enter the same time zone as the physical location of the installed OmniLogic, otherwise schedules and timers will be inaccurate. You'll also be asked for an MSP System ID. This number can be found directly from the OmniLogic. To find your unit's MSP ID, follow the procedure below:

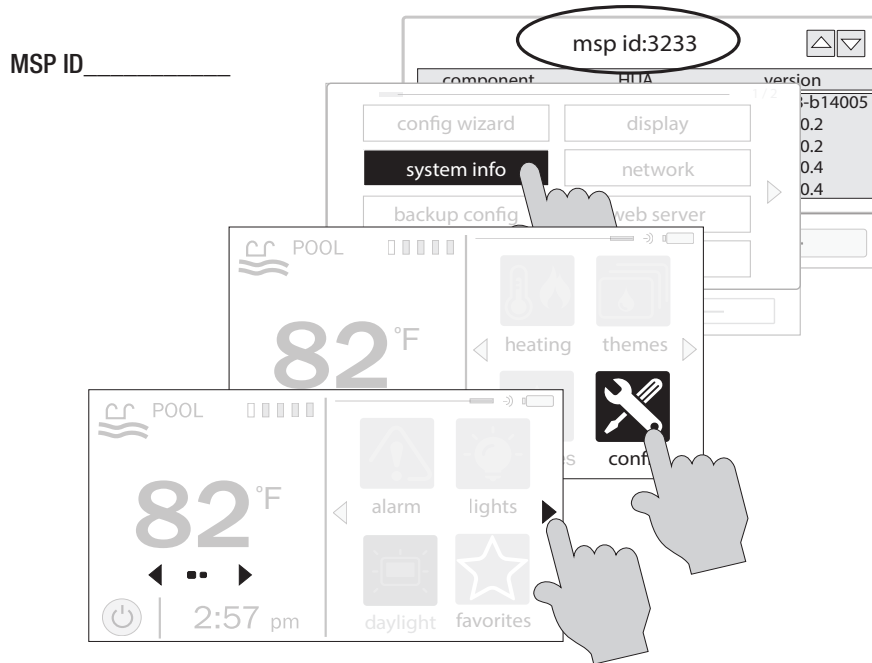

After the MSP is accepted, the OmniLogic will be linked to your account. You'll be able to access the OmniLogic at any time from your browser by logging into your account at haywardomnilogic.com. For mobile devices, an application must be downloaded from your device's app store. Go to www.hayward.com for more information on the availability and function of mobile apps.





HAYWARD®

LIMITED WARRANTY Hayward warrants its OmniLogic, Pro Logic, OnCommand and E-Command pool automation products as well as its Aqua Rite, Aqua Rite Pro, Aqua Plus and SwimPure chlorination products to be free of defects in materials and workmanship, under normal use and service, for a period of three (3) years. Hayward also warrants its Aqua Trol chlorination products to be free of defects in materials and workmanship, under normal use and service for a period of one (1) year. These warranties are applicable from the date of purchase and only for products used exclusively on private residential swimming pools in the US and Canada. Such products for use on commercial pools in the US and Canada are covered for a period of one (1) year from date of purchase for defects in materials and workmanship. Hayward warrants all accessories and replacement parts for the above-identified pool automation and chlorination products for a period of one (1) year. Accessories include remotes, actuators, base stations, temperature sensors, flow switches and chemistry probes. Each of these warranties is not transferable and applies only to the original owner.

Hayward shall not be responsible for cartage, removal, repair or installation labor or any other such costs incurred in obtaining warranty replacements or repair.

Proof of purchase is required for warranty service. If written proof of purchase is not provided, the manufacturing date code will be the sole determinant of the date of purchase of the product. To obtain warranty service or repair, please contact the place of purchase or the nearest Hayward authorized warranty service center. For more information on authorized service centers please contact the Hayward Technical Service Support Center (61 Whitecap Road, North Kingstown RI, 02852) or visit the Hayward website at www.hayward.com.

WARRANTY EXCLUSIONS:

1. Use of non-Hayward material or unauthorized workmanship during installation.
2. Damage resulting from improper installation including installation on pools larger than the product rating.
3. Problems resulting from failure to install, operate or maintain the product(s) in accordance with the recommendations contained in the owner's manual(s).
4. Problems resulting from failure to maintain pool water chemistry in accordance with the recommendations in the owner's manual(s).
5. Problems resulting from tampering, accident, abuse, negligence, unauthorized repairs or alternations, fire, flood, lightning, freezing, external water, degradation of natural stone used in or immediately adjacent to a pool or spa, war or acts of God.
6. Use of a non- Hayward replacement salt chlorination cell on any Hayward automation or chlorination product.

The express limited warranty above constitutes the entire warranty of Hayward Pool Products with respect to its products and is in lieu of all other warranties, express or implied, including warranties of merchantability or fitness for a particular purpose. In no event shall Hayward Pool products be responsible for any consequential, special or incidental damages of any nature. Some states do not allow a limitation on how long an implied warranty lasts, or the exclusion of incidental or consequential damages, so the above limitation may not apply to you. This warranty gives you specific legal rights, and you may also have other rights, which vary from state to state.



HAYWARD®



⚠ WARNING - Read and follow all instructions in this owner's manual and on the equipment. Failure to follow instructions can cause severe injury and/or death.

⚠ WARNING – Suction Entrapment Hazard.



Suction in suction outlets and/or suction outlet covers which are, damaged, broken, cracked, missing, or unsecured can cause severe injury and/or death due to the following entrapment hazards:



Hair Entrapment- Hair can become entangled in suction outlet cover.



Limb Entrapment- A limb inserted into an opening of a suction outlet sump or suction outlet cover that is damaged, broken, cracked, missing, or not securely attached can result in a mechanical bind or swelling of the limb.



Body Suction Entrapment- A negative pressure applied to a large portion of the body or limbs can result in an entrapment.

Evisceration/ Disembowelment - A negative pressure applied directly to the intestines through an unprotected suction outlet sump or suction outlet cover which is, damaged, broken, cracked, missing, or unsecured can result in evisceration/ disembowelment.



Mechanical Entrapment- There is potential for jewelry, swimsuit, hair decorations, finger, toe or knuckle to be caught in an opening of a suction outlet cover resulting in mechanical entrapment.

⚠ WARNING - To Reduce the risk of Entrapment Hazards:

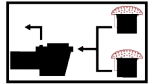

- o When outlets are small enough to be blocked by a person, a minimum of two functioning suction outlets per pump must be installed. Suction outlets in the same plane (i.e. floor or wall), must be installed a minimum of three feet (3') [1 meter] apart, as measured from near point to near point.
- o Dual suction fittings shall be placed in such locations and distances to avoid “dual blockage” by a user.
- o Dual suction fittings shall not be located on seating areas or on the backrest for such seating areas.
- o The maximum system flow rate shall not exceed the flow rating of as listed on Table 1.
- o Never use Pool or Spa if any suction outlet component is damaged, broken, cracked, missing, or not securely attached.
- o Replace damaged, broken, cracked, missing, or not securely attached suction outlet components immediately.
- o In addition two or more suction outlets per pump installed in accordance with latest ASME, APSP Standards and CPSC guidelines, follow all National, State, and Local codes applicable.
- o Installation of a vacuum release or vent system, which relieves entrapping suction, is recommended.

⚠ WARNING – Failure to remove pressure test plugs and/or plugs used in winterization of the pool/spa from the suction outlets can result in an increase potential for suction entrapment as described above.

⚠ WARNING – Failure to keep suction outlet components clear of debris, such as leaves, dirt, hair, paper and other material can result in an increase potential for suction entrapment as described above.

⚠ WARNING – Suction outlet components have a finite life, the cover/grate should be inspected frequently and replaced at least every ten years or if found to be damaged, broken, cracked, missing, or not securely attached.

⚠ CAUTION – Components such as the filtration system, pumps and heater must be positioned so as to prevent their being used as means of access to the pool by young children. To reduce risk of injury, do not permit children to use or climb on this product. Closely supervise children at all times. Components such as the filtration system, pumps, and heaters must be positioned to prevent children from using them as a means of access to the pool.



⚠ WARNING – Hazardous Pressure. Pool and spa water circulation systems operate under hazardous pressure during start up, normal operation, and after pump shut off. Stand clear of circulation system equipment during pump start up. Failure to follow safety and operation instructions could result in violent separation of the pump housing and cover, and/or filter housing and clamp due to pressure in the system, which could cause property damage, severe personal injury, or death. Before servicing pool and spa water circulation system, all system and pump controls must be in off position and filter manual air relief valve must be in open position. Before starting system pump, all system valves must be set in a position to allow system water to return back to the pool. Do not change filter control valve position while system pump is running. Before starting system pump, fully open filter manual air relief valve. Do not close filter manual air relief valve until a steady stream of water (not air or air and water) is discharged.



⚠ WARNING – Separation Hazard. Failure to follow safety and operation instructions could result in violent separation of pump and/or filter components. Strainer cover must be properly secured to pump housing with strainer cover lock ring. Before servicing pool and spa circulation system, filters manual air relief valve must be in open position. Do not operate pool and spa circulation system if a system component is not assembled properly, damaged, or missing. Do not operate pool and spa circulation system unless filter manual air relief valve body is in locked position in filter upper body. **Never operate or test the circulation system at more than 50 PSI.**



⚠ WARNING – Risk of Electric Shock. All electrical wiring **MUST** be in conformance with applicable local codes, regulations, and the National Electric Code (NEC). Hazardous voltage can shock, burn, and cause death or serious property damage. To reduce the risk of electric shock, do **NOT** use an extension cord to connect unit to electric supply. Provide a properly located electrical receptacle. Before working on any electrical equipment, turn off power supply to the equipment. To reduce the risk of electric shock replace damaged wiring immediately. Locate conduit to prevent abuse from lawn mowers, hedge trimmers and other equipment. Do **NOT** ground to a gas supply line.

⚠ WARNING – Risk of Electric Shock Failure to ground all electrical equipment can cause serious or fatal electrical shock hazard. Electrical ground all electrical equipment before connecting to electrical power supply.

⚠ WARNING – Risk of Electric Shock Failure to bond all electrical equipment to pool structure will increase risk for electrocution and could result in injury or death. To reduce the risk of electric shock, see installation instructions and consult a professional electrician on how to bond all electrical equipment. Also, contact a licensed electrician for information on local electrical codes for bonding requirements.

Notes to electrician: Use a solid copper conductor, size 8 or larger. Run a continuous wire from external bonding lug to reinforcing rod or mesh. Connect a No. 8 AWG (8.4 mm²) [No. 6 AWG (13.3 mm²) for Canada] solid copper bonding wire to the pressure wire connector provided on the electrical equipment and to all metal parts of swimming pool, spa, or hot tub, and metal piping (except gas piping), and conduit within 5 ft. (1.5 m) of inside walls of swimming pool, spa, or hot tub.

IMPORTANT - Reference NEC codes for all wiring standards including, but not limited to, grounding, bonding and other general wiring procedures.

⚠ WARNING – Risk of Electric Shock . The electrical equipment must be connected only to a supply circuit that is protected by a ground-fault circuit-interrupter (GFCI). Such a GFCI should be provided by the installer and should be tested on a routine basis. To test the GFCI, push the test button. The GFCI should interrupt power. Push reset button. Power should be restored. If the GFCI fails to operate in this manner, the GFCI is defective. If the GFCI interrupts power to the electrical equipment without the test button being pushed, a ground current is flowing, indicating the possibility of an electrical shock. Do not use this electrical equipment. Disconnect the electrical equipment and have the problem corrected by a qualified service representative before using.

⚠ CAUTION – HAYWARD® pumps are intended for use with permanently-installed pools and may be used with hot tubs and spas if so marked. Do not use with storable pools. A permanently-installed pool is constructed in or on the ground or in a building such that it cannot be readily disassembled for storage. A storable pool is constructed so that it is capable of being readily disassembled for storage and reassembled to its original integrity.

SAVE THESE INSTRUCTIONS

FOR FURTHER INFORMATION OR CONSUMER
TECHNICAL SUPPORT, VISIT OUR WEBSITE AT
www.hayward.com



Hayward is a registered trademark. © 2016 Hayward Industries, Inc.

All other trademarks not owned by Hayward are the property of their respective owners.
Hayward is not in any way affiliated with or endorsed by those third parties.



092473

USE ONLY HAYWARD GENUINE REPLACEMENT PARTS



OmniLogic®

Automation and Chlorination

Installation Manual



The image shows a tall, grey metal control panel for the OmniLogic system. The top of the panel features the Hayward logo and the 'OmniLogic' branding. Below the panel, three mobile devices are displayed: a smartphone, a tablet, and a smaller tablet, all showing the OmniLogic control interface with various data points and graphs.

Contents

- Before You Begin.....1
- Overview.....1
- Mounting Equipment.....4
- Plumbing.....6
- Wiring.....10
- Preparing Pool/Spa Water.....21
- System Startup.....23
- Configuration Wizard.....24

HLBASE

Hayward Pool Products
620 Division Street, Elizabeth NJ 07207
Phone: (908) 355-7995
www.hayward.com



HAYWARD®

IMPORTANT SAFETY INSTRUCTIONS

When using this electrical equipment, basic safety precautions should always be followed, including the following:

- **READ AND FOLLOW ALL INSTRUCTIONS**
- **WARNING:** Disconnect all AC power during installation.
- **WARNING:** Water in excess of 100 degrees Fahrenheit may be hazardous to your health.
- **WARNING:** To reduce the risk of injury, do not permit children to use this product unless they are closely supervised at all times.
- **WARNING:** Do not use the OmniLogic to control fire pits or related fire equipment.
- A green colored terminal marked “Grounding” is located inside the wiring compartment. To reduce the risk of electric shock, this terminal must be connected to the grounding means provided in the electric supply service panel with a continuous copper wire equivalent in size to the circuit conductors supplying the equipment.
- One bonding lug for US models is provided on the external surface. To reduce the risk of electric shock, connect the local common bonding grid in the area of the swimming pool, spa, or hot tub to these terminals with an insulated or bare copper conductor not smaller than 8 AWG US / 6 AWG Canada.
- All field installed metal components such as rails, ladders, drains, or other similar hardware within 3 meters of the pool, spa or hot tub shall be bonded to the equipment grounding bus with copper conductors not smaller than 8 AWG US / 6 AWG Canada.
- **SAVE THESE INSTRUCTIONS**



FCC Statement

This device complies with part 15 of the FCC rules. Operation is subject to the following two conditions: (1) This device may not cause harmful interference, and (2) this device must accept any interference received, including interference that may cause undesired operation.

Changes or modifications not expressly approved by Hayward could void the user's authority to operate this equipment.

NOTE: This equipment has been tested and found to comply with the limits for a Class B digital device, pursuant to Part 15 of the FCC Rules. These limits are designed to provide reasonable protection against harmful interference in a residential installation. This equipment generates, uses and can radiate radio frequency energy and, if not installed and used in accordance with the instructions, may cause harmful interference to radio communications. However, there is no guarantee that interference will not occur in a particular installation. If this equipment does cause harmful interference to radio or television reception, which can be determined by turning the equipment off and on, the user is encouraged to try to correct the interference by one or more of the following measures:

- Reorient or relocate the receiving antenna.
- Increase the separation between the equipment and receiver.
- Connect the equipment into an outlet on a circuit different from that to which the receiver is connected.
- Consult the dealer or an experienced radio / TV technician for help.

Industry Canada Statement

This Class B digital apparatus complies with Canadian ICES-003.

Cet appareil numérique de la classe B est conforme à la norme NMB-003 du Canada.

The term "IC" before the certification / registration number only signifies that the Industry Canada technical specifications were met.



Table of Contents

| | | |
|-------------------------------------|--|----|
| Introduction | Installation Steps..... | 3 |
| Preparing Mounting Equipment | OmniLogic Enclosure..... | 4 |
| | Temperature Sensors..... | 5 |
| | Optional Chlorination..... | 5 |
| | Optional HL-CHEM Sensing Kit..... | 5 |
| | Optional AQL-CHEM2 pH Dispensing..... | 5 |
| | Optional HLWALLMOUNT..... | 5 |
| | Optional HLWLAN..... | 5 |
| | Optional Valve Actuators..... | 6 |
| Plumbing | Pool/Spa Configuration..... | 6 |
| | TurboCell..... | 9 |
| | Flow Switch..... | 9 |
| Electrical Wiring | Main Service..... | 11 |
| | Grounding and Bonding..... | 11 |
| | Circuit Breaker Installation and Wiring..... | 11 |
| | General Purpose Outlet..... | 11 |
| | OmniLogic Power..... | 11 |
| | Pool Equipment Connection Table..... | 12 |
| | High Voltage Pool Equipment..... | 13 |
| | Low Voltage Wiring..... | 14 |
| Pool/Spa Water | General Water Chemistry..... | 21 |
| | Salt..... | 22 |
| Final Steps | System Startup..... | 23 |
| Startup and Configuration | Startup and Configuration Wizard..... | 24 |
| | Bodies of Water..... | 25 |
| | Filter Pumps..... | 26 |
| | Heaters..... | 27 |
| | HL-CHEM..... | 28 |
| | Chlorinator..... | 29 |
| | Cleaners..... | 29 |
| | Water Features..... | 30 |
| | ColorLogic Lights..... | 31 |
| | Other Lights..... | 31 |
| | Accessories..... | 32 |
| | Shared Equipment..... | 33 |
| | Sensors..... | 33 |
| | Backyard Accessories..... | 34 |
| | Interlocks..... | 34 |
| | Quick Edit..... | 37 |
| Warranty | OmniLogic Limited Warranty..... | 43 |



Before you Begin

What's Included

Before attempting to install the OmniLogic system, check that the following components have been included in the package:

- OmniLogic Electronics Unit
- (3) Temperature sensors with 15 ft. (5m) cable, hose clamp
- Ferrite bead for ethernet cable
- Spare main board fuses

What's NOT Included

Some of the additional items that you may need to complete an installation include:

Circuit breakers

None are included with control—see page 11 and inside door label for suitable breakers

Wire

- 4-conductor cable for connection to optional wired terminal(s)
- Wire/conduit for 125A service from main panel to OmniLogic
- Wire/conduit for filter pump and other high voltage loads
- Wire for remote heater control and other low voltage devices
- Wire for bonding

Miscellaneous

- Optional utility electrical outlet and weatherproof cover (for mounting on lower right side of OmniLogic)
- Mounting hardware (screws, bolts, etc.) for mounting OmniLogic and remote terminals
- Valve Actuators (to automate valve functions)

Accessory Products - Order Separately

| | |
|-------------|--|
| HLRELAYBANK | Additional relay pack adds 4 high voltage relays |
| HLRELAY | Single high voltage relay kit |
| HLIOEXPAND | Input/Output Expander Board adds 4 additional sensor/external inputs, 4 heater/low voltage outputs, and 4 actuator outputs |
| HLWLAN | Wireless home network connectivity - eliminates the need to hard wire the OmniLogic to the home's router/access point |
| HLWALLMOUNT | Wired Wall Mount Remote Terminal |
| HL-CHEM | ORP & pH Sensing Kit for monitoring and controlling pool chemistry |
| GVA-24 | Valve Actuator |
| V&A-xx | Valve & Actuator (xx=1P (1.5" pos. seal), -2P (2" pos. seal) |
| T-CELL-3 | Chlorinator Cell - generates chlorine for pools up to 15k gallons |
| T-CELL-9 | Chlorinator Cell - generates chlorine for pools up to 25k gallons |
| T-CELL-15 | Chlorinator Cell - generates chlorine for pools up to 40k gallons |
| P-KIT | Chlorination plumbing kit containing flow switch and cell unions |

NOTE: Before installing this product as part of a saline water purification system in a pool or spa using natural stone for coping or for immediately adjacent patios/decking, a qualified stone installation specialist should be consulted regarding the appropriate type, installation, sealant (if any) and maintenance of stone used around a saline pool with an electronic chlorine generator in your particular location and circumstances.

NOTE: The use of dry acid (sodium bisulfate) to adjust pool pH is discouraged especially in arid regions where pool water is subject to excessive evaporation and is not commonly diluted with fresh water. Dry acid can cause a buildup of by-products that can damage your chlorinator cell.

Overview

The OmniLogic HLBASE is a multifunction pool automation control that is expandable to meet all your needs and fully manage your pool/spa system. The OmniLogic can control pumps, valves, lighting, heaters, pool chemistry and more. It offers the next generation of technology to manage pool/spa equipment and the backyard experience. Using a touchscreen interface and network connectivity, the OmniLogic gives the user complete control over both automation and chlorination of their pool and spa.

Although the OmniLogic is easy to use, it is important to completely read through this manual before attempting to install, configure or operate the unit.

Features

The standard Hayward HLBASE OmniLogic offers the following features:

- control up to 4 (expandable to 10) high voltage (120/240V) relays to control pumps, pool lights, yard lights, water features, chemical dispensers and more
- control up to 4 (expandable to 8) automatic valve actuators including pool and spa valves, water feature valves, cleaner valves and more
- control up to 4 (expandable to 8) heaters or low voltage equipment including gas heaters, electric heat pumps, and solar heaters as well as various low voltage devices
- controls up to 16 Ecostar variable speed pumps without the use of a relay
- inputs for up to 4 temperature sensors or external input devices (expandable to 8)
- ethernet port for wired connection to the home's router/access point allowing communication to devices on the home network or on the web
- 125A electrical subpanel that can accommodate up to 12 circuit breakers
- connection for Hayward TurboCell used to generate chlorine
- connection for flow switch used to detect water flow
- input for ORP and pH sensing (HL-CHEM)
- connection for Expansion Panel if more than one OmniLogic is required

Optional accessories (page 1) can expand the functionality of the HLBASE. Determine your needs and select the necessary HLBASE accessories before you begin the installation.

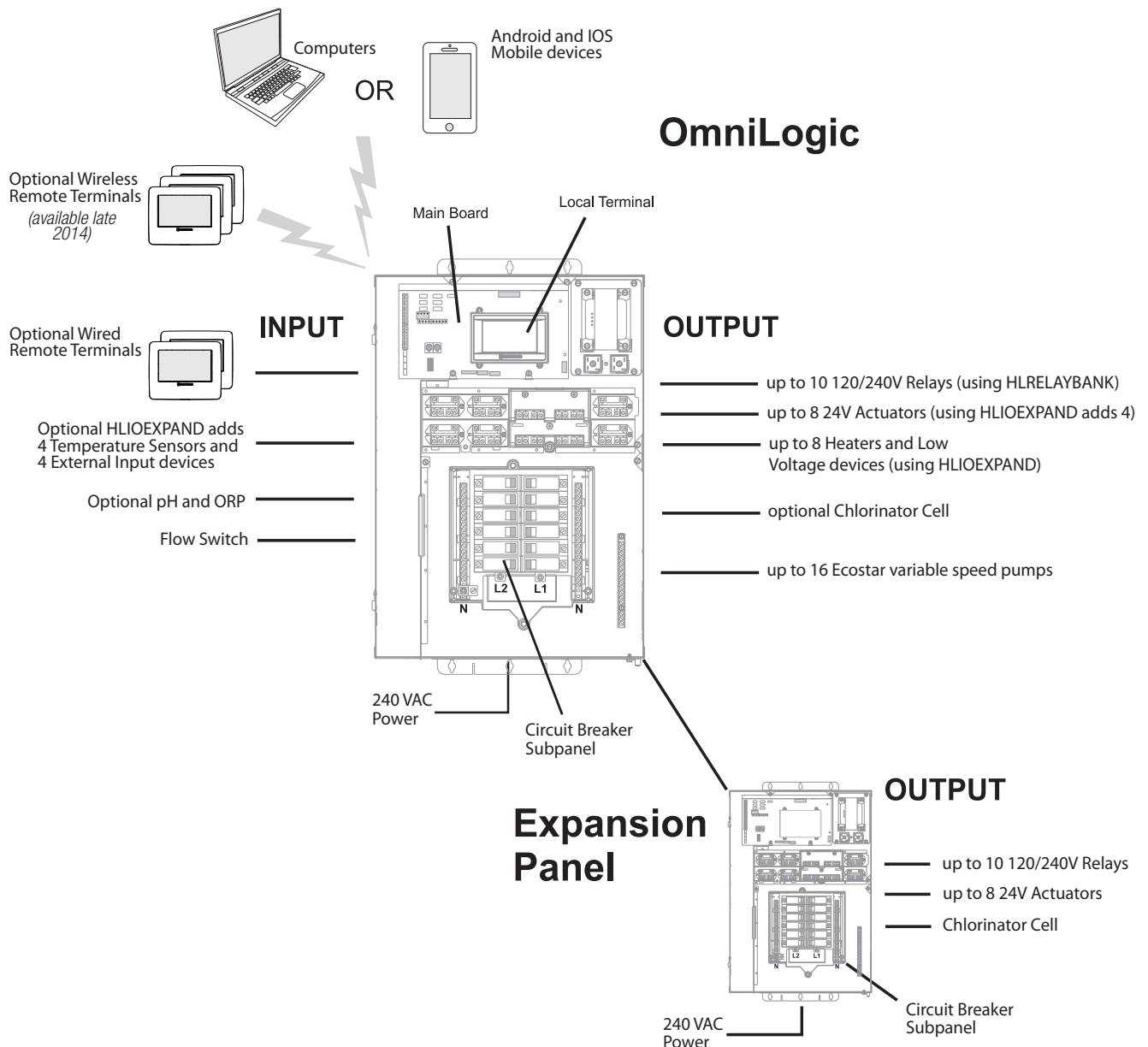



Installation Steps

DANGER of Death, Injury or Property Damage if procedure not followed. Dead front removal is required for this installation. Power to the OmniLogic panel **MUST** be shut off before the dead front is removed. This means a complete shutdown of power to the entire OmniLogic panel.

Details on each installation step are presented on the following pages:

1. Mounting the equipment (page 4)
 - OmniLogic main unit
 - Temperature sensors
 - Remote display/keypad (optional)
 - Valve actuators (if applicable)
2. Plumbing (page 6)
 - General Pool Equipment
 - TurboCell
 - Flow Switch
3. Electrical Wiring (page 10)
 - Main service
 - Grounding and bonding
 - Circuit breakers
 - OmniLogic power
 - High Voltage pool equipment
 - Low voltage wiring (temperature sensors, flow switch, etc.)
4. Prepare the pool water (page 21)
 - General Water Chemistry
 - Salt
5. System Startup and Firmware Upgrade (page 23)

NOTE: If replacing a Pro Logic Controller using networked ColorLogic Lights, the lights must be put into "Standalone" (default) mode before disconnecting the Pro Logic. The OmniLogic can only control ColorLogic lights in "Standalone" mode.



Mounting the Equipment

OmniLogic Enclosure

The OmniLogic is contained in a raintight enclosure that is suitable for outdoor mounting. The control must be mounted a minimum of 6 ft. (2 meters) horizontal distance from the pool/spa (or more, if local codes require). The OmniLogic is designed to mount vertically on a flat surface with the knockouts facing downward. Because the enclosure also acts as a heat sink (disperses heat from inside the box), it is important not to block the four sides of the control. Do not mount the OmniLogic inside a panel or tightly enclosed area.

When selecting a location, note that the standard cables supplied with the included flow switch and temperature sensors, as well as optional accessories like Hayward TurboCells and actuators are all 15 ft. (5m) long. Try to mount the OmniLogic at a height where the touchscreen can be accessed easily.

The OmniLogic weighs close to 60lbs. and will require two people to position and install. Select the proper location and mounting hardware given the size and weight of the unit. The OmniLogic mounting brackets require a total of 6 mounting bolts to fasten the OmniLogic to the mounting surface.

Note that there is a heat sink on the back of the enclosure. Refer to the following information regarding the OmniLogic heat sink:

In all cases the heat sink on the back of the OmniLogic panel should not contact the wall behind the panel. This restricts air flow and makes the heat sink less efficient. A minimum separation of 1/8" (except for vinyl siding) should be maintained between any heat sink pin and the siding on the wall behind the enclosure. In the case of a flat wall the mounting flanges on the enclosure ensure that the minimum clearance is maintained. For shingles, clapboards or other siding with a non-flat profile, the installer must ensure the minimum separation. Refer to the diagram on below.

Special Installation Instructions for Vinyl Siding

IMPORTANT: The heat sink on the back of the OmniLogic panel cannot be allowed to contact vinyl siding; during normal chlorinator operation the heat sink pins get warm enough to deform vinyl siding on contact. An increased minimum separation of 3/8" should be maintained between any heat sink pin and the vinyl siding behind the enclosure.

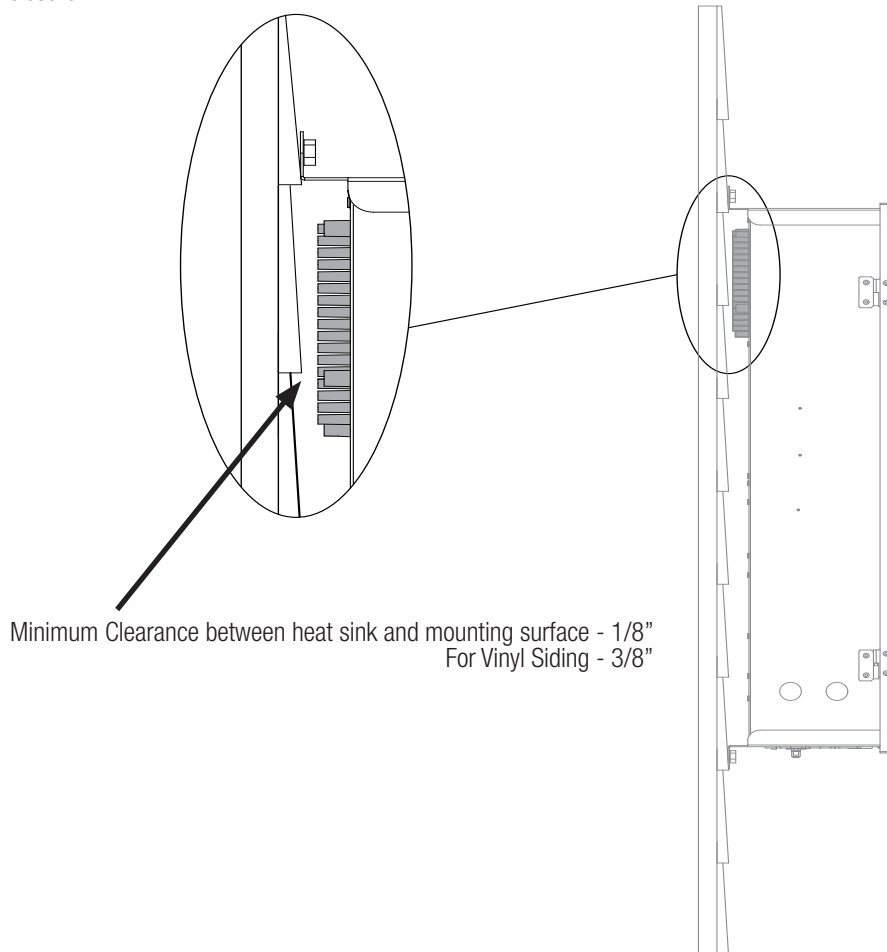



Temperature Sensors

Three sensors are included with the OmniLogic. A water sensor and an air sensor must be installed at all times for proper operation. A solar sensor is required if the solar function is enabled.

Water Sensor

This sensor is used to measure the pool/spa temperature and is installed in the filtration plumbing after the filter but before either the solar or conventionally fueled heaters—refer to the plumbing overview diagram.

1. Drill a 3/8" (10mm) diameter hole in the PVC piping and remove all chips and burrs.
2. Insert sensor until O-ring collar sits flush on the hole.
3. Position hose clamp over the sensor and gently tighten until O-ring makes an adequate seal. Do not overtighten.

Air Sensor

Mount the air sensor outdoors. **IMPORTANT:** The air sensor must not be mounted in direct sunlight.

Solar Sensor

For solar applications, mount the sensor near the solar collector array so that it is exposed to the same sunlight as the collectors. Use additional cable (20 AWG) if necessary.

Optional Chlorination Function

The OmniLogic model requires the use of a chlorinator cell and plumbing kit to provide pool chlorination. These items are not included with the OmniLogic and can be purchased separately at your local Hayward dealer. Choose a chlorinator cell model based on the size of your pool. The following models are available:

T-CELL-15 for pools up to 40,000 gallons
T-CELL-9 for pools up to 25,000 gallons
T-CELL-3 for pools up to 15,000 gallons

In addition to the chlorinator cell, a plumbing kit (P-KIT) must be purchased. This kit contains the cell unions and flow switch. Refer to pages 9 and 20 for plumbing and wiring instructions.

Optional HL-CHEM Sensing Kit

The HL-CHEM is an ORP and pH sensing kit for the OmniLogic. When chlorination is enabled (requires chlorinator cell and P-KIT), the OmniLogic senses the pool's ORP and pH levels and generates the correct amount of chlorine to keep your pool properly sanitized. Wiring and plumbing requirements for the HL-CHEM should be considered before installing the OmniLogic. Refer to the HL-CHEM manual for specific installation information. **NOTE:** OmniLogic is not compatible with AQL-CHEM.

Optional AQL-CHEM2 CO2 Dispensing Kit

The AQL-CHEM2 is a CO2 dispensing device that connects directly to the OmniLogic. When used with an HL-CHEM, the OmniLogic will sense the pool's pH level and automatically dispense the correct amount of CO2 to control the pool's pH to the desired level. Wiring and plumbing requirements for the AQL-CHEM2 should be considered before installing the OmniLogic. Refer to the AQL-CHEM2 manual for specific installation information.

Optional Wired Remote Terminal

Hayward offers an optional wired remote terminals for the OmniLogic, giving you the ability to control your pool's functions from a remote location, away from the pool pad. The OmniLogic can also be controlled remotely by various internet enabled devices such as phones, tablets and PCs.

HLWALLMOUNT

The HLWALLMOUNT is a wired touchscreen remote terminal designed to be mounted up to 500' away (depending on cable gauge) from the OmniLogic. The HLWALLMOUNT must be mounted indoors or in a weather protected area (rain should never touch the unit). It can mount over a single gang electrical utility box or can be mounted directly onto any wall surface. When selecting a mounting location, refer to the HLWALLMOUNT manual for more information. Up to two HLWALLMOUNTs can be connected to the OmniLogic.

Networking and Web Enabled Devices

The OmniLogic offers ethernet connectivity to the web through the home's network. Once connected, web enabled devices such as a PC, laptop, tablet or phone can be used to control and monitor the OmniLogic. For web connectivity, an ethernet cable must be run from the OmniLogic to the router or access point or a wireless connection can be made to the home's router using an optional HLWLAN.

HLWLAN

If running ethernet cable from the home's router/access point to the OmniLogic is impractical, an optional HLWLAN can be used. The HLWLAN is a 802.11b/g/n transceiver kit that can make a wireless connection up to 250' to the home's router/access point preventing the need to run cable for web access. Refer to the HLWLAN Owner's Manual for wiring and configuration information.

Optional Valve Actuators

For optional actuators used with the OmniLogic—note that the internal cams in the actuator may also have to be adjusted depending on the way the actuator is mounted on the valve and the desired valve action.

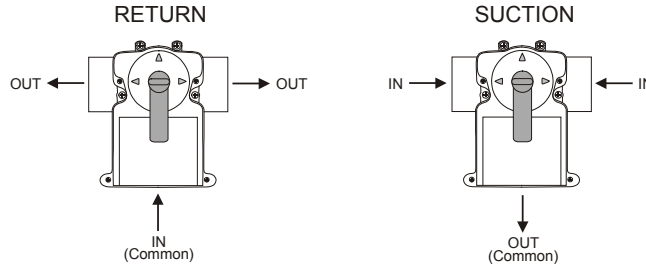

Plumbing

Pool/Spa System Configuration

These systems use a single filter pump and filter. Pool or spa operation is controlled by two 3-way valves (suction and return). Refer to the diagram below.

| High Voltage Relays | Valve Outputs |
|---------------------|------------------|
| Filter Pump | Pool/Spa Suction |
| Lights | Pool/Spa Return |
| Aux 1 | Valve 3 |
| Aux 2 | Valve 4 |

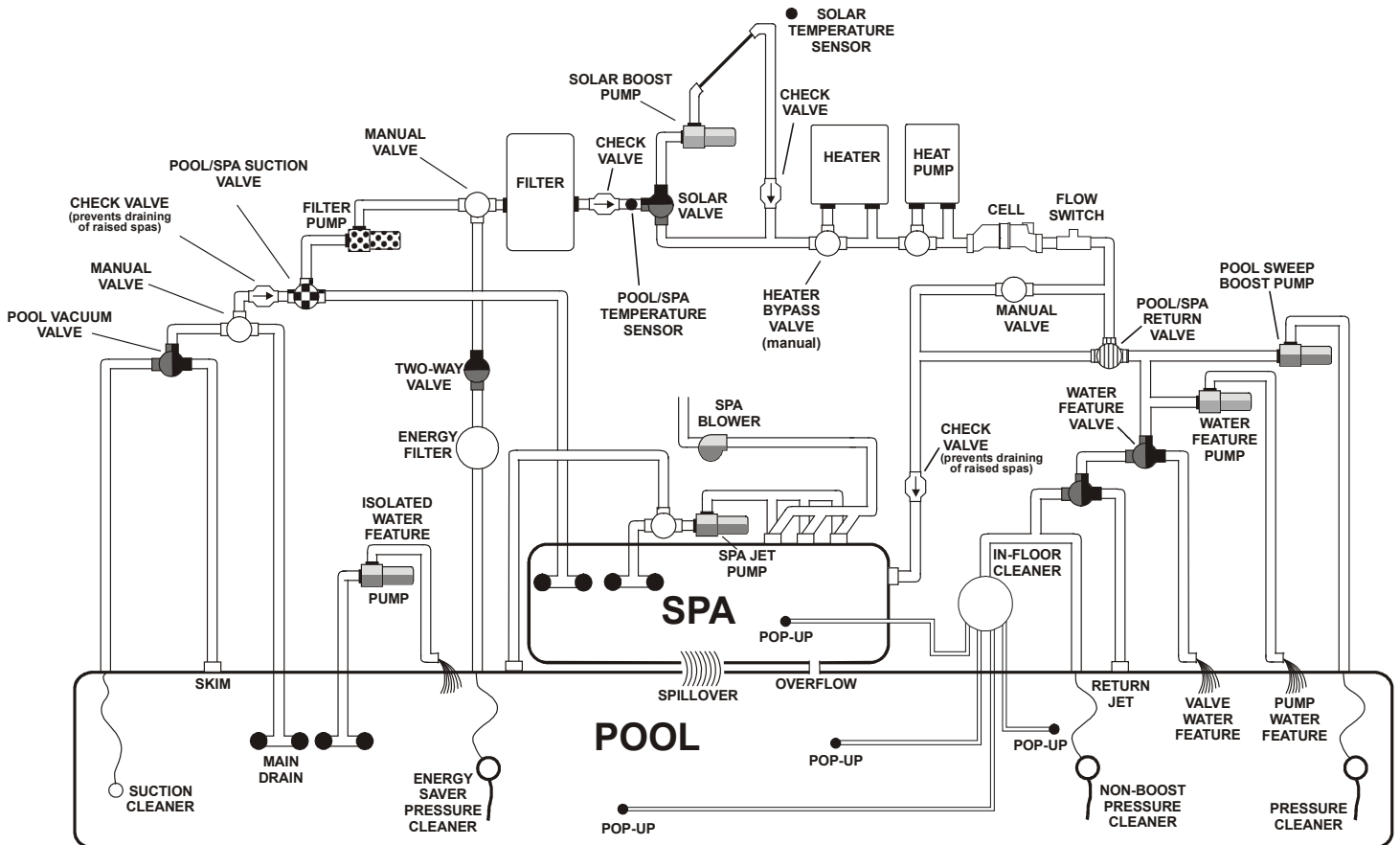
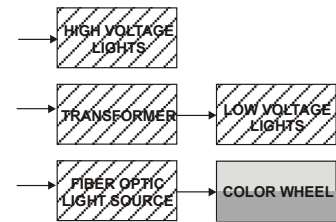

Some important notes regarding standard Pool/Spa systems:

1. The OmniLogic can be programmed to accommodate spa spillover, if desired.
2. A conventional heater (gas or heat pump) and solar can be used to heat both the pool and the spa.
3. If the chlorinator cell is plumbed prior to the pool/spa return valve, then both the pool and the spa can be chlorinated.
4. The water sensor should be installed prior to any heater or solar and will display either the pool or the spa temperature, depending on the current operation of the pool. The temperature will only be displayed when the filter pump is running.
5. If any water feature or pressure side cleaner boost pumps are used, be sure to enable the "interlock" feature (see CONFIGURATION for details) to ensure that the pumps operate only when the filter pump is on and the system is in the "pool only" operating mode.
6. The plumbing diagram above is intended to be used as a general guideline and is not a complete plumbing schematic for the pool.
7. The air sensor must be installed if the freeze protection feature is enabled for the filter, valves, chlorinator, other pool functions.

"Dual Equipment - Separate Heaters" for Pool/Spa Configuration

These systems have 2 complete sets of equipment (filter pump, filter, heater)—1 set for the pool and the other set for the spa. Refer to the diagram below:

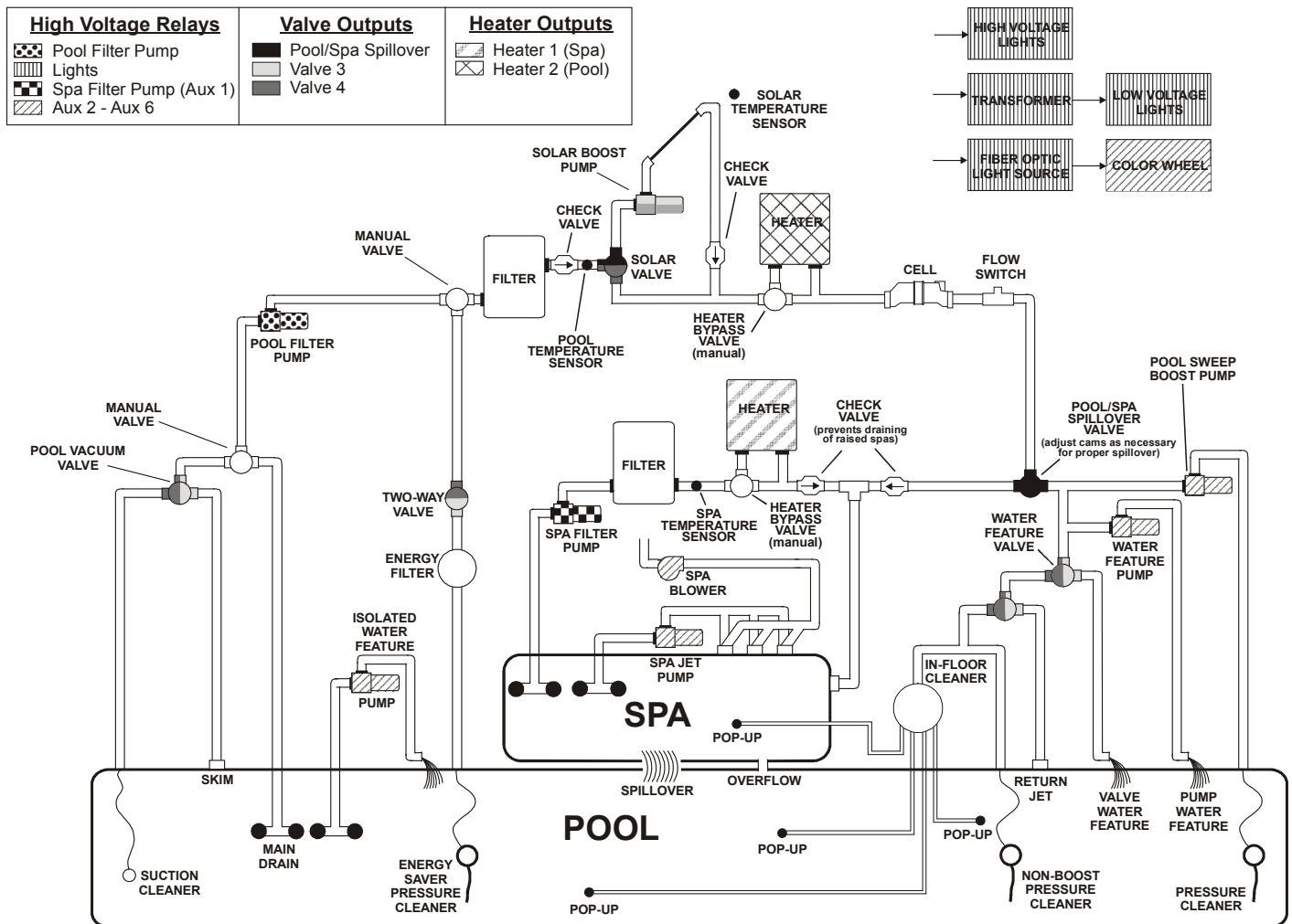

Some important notes regarding the control of Dual Equipment Pool/Spa systems with separate heaters:

1. When the system is configured for Dual Equipment:
 - a. The pool filter can be a one, two or variable speed pump.
 - b. The spa filter can be a one, two or variable speed pump.
2. The water sensor should be installed on the pool loop prior to the heater and will display the pool temperature whenever the "Pool Filter" pump is running.
3. The dual equipment spa sensor should be installed on the spa loop prior to the heater and will display the spa temperature whenever the "Spa Filter" pump is running.

4. The OmniLogic can be programmed to accommodate spillover if desired. Note that spillover operation will be automatically suspended whenever the spa filter pump is turned on.
5. The chlorinator cell must be installed in the pool plumbing. If spillover is enabled, then the OmniLogic can chlorinate both the pool and spa (during spillover operation). Otherwise, the OmniLogic will only chlorinate the pool and the spa sanitization will have to be handled manually.
6. If any water feature or pressure side cleaner boost pumps are used, be sure to enable the “interlock” feature (see CONFIGURATION for details) to ensure that the pumps operate only when the “Pool Filter” pump is on and the system is in the “pool only” operating mode.
7. The plumbing diagram on page 6 is intended to be used as a general guideline and is not a complete plumbing schematic for the pool.

“Dual Equipment - Shared Heaters” for Pool/Spa Configuration

These systems have 2 complete sets of equipment (filter pump, filter) and shared heaters. Refer to the diagram below:

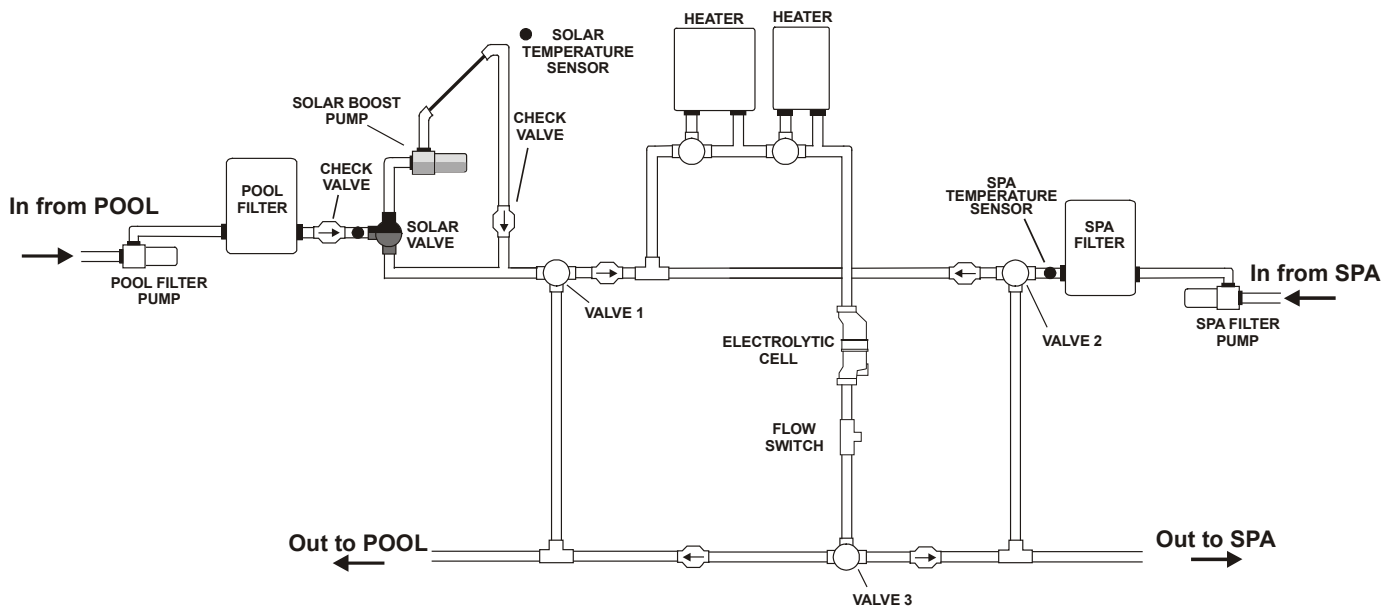

Some important notes regarding the control of Dual Equipment Pool/Spa systems with shared heaters:

In the Pool/Spa Config., select:

1. When the system is configured for Dual Equipment:
 - a. The pool filter can be a one, two or variable speed pump.
 - b. The spa filter can be a one, two or variable speed pump.
 - c. The heater(s) will be dedicated to the spa whenever the spa filter is on and the spa temperature setting is not off.
2. The water sensor should be installed on the pool loop prior to the heater(s) and will display the pool temperature whenever the “Pool Filter” pump is running.
3. The dual equipment spa sensor should be installed on the spa loop prior to the heater(s) and will display the spa temperature whenever the “Spa Filter” pump is running.
4. The OmniLogic can be programmed to accommodate spillover if desired. Note that spillover operation will be automatically suspended whenever the spa filter pump is turned on.
5. The chlorinator cell and flow switch must be installed in the heater return path. If spillover is enabled, then the OmniLogic can chlorinate both the pool and spa (during spillover operation). Otherwise, the OmniLogic will only chlorinate the pool when the spa does not control the heater(s) and the spa sanitization will have to be handled manually.
6. If any water feature or pressure side cleaner boost pumps are used, be sure to enable the “interlock” feature (see CONFIGURATION for details) to ensure that the pumps operate only when the “Pool Filter” pump is on and the system is in the “pool only” operating mode.
7. The plumbing diagram on page 6 is intended to be used as a general guideline and is not a complete plumbing schematic for the pool.



Optional TurboCell

The TurboCell (used for chlorine generation) must be plumbed AFTER the filter and heater. If installed on a pool/spa combination system, the cell must be plumbed BEFORE the pool/spa return valve in order to allow proper chlorination of both the pool and the spa. Refer to plumbing diagram below:

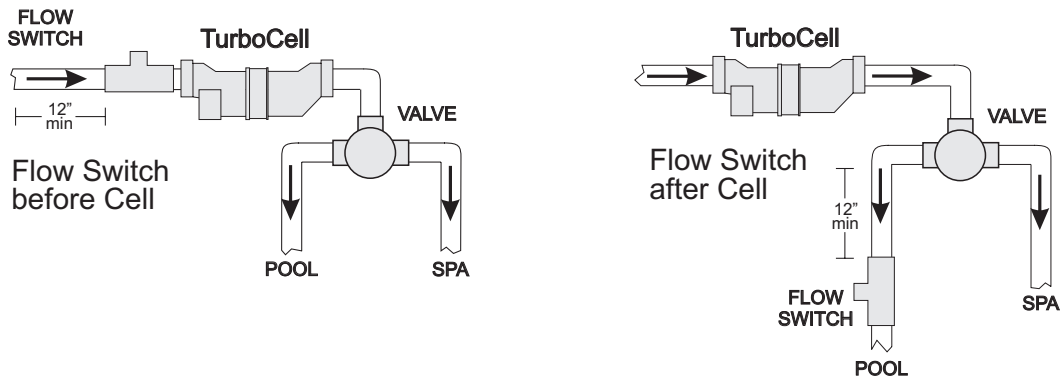

The cell may be mounted vertically or horizontally, and water can move in either direction through the cell. Install using the 2" unions provided. Tighten unions BY HAND for a watertight seal. For systems with 1½" plumbing use adapters (provided by installer).

Flow Switch (supplied with P-KIT)

A Hayward flow switch is required if using the optional TurboCell for chlorination or an AQL-CHEM2 for pH dispensing. The flow switch is a safety device that ensures that water is flowing through the cell before the OmniLogic starts to generate chlorine or dispenses acid.

The flow switch must be plumbed in the same section of plumbing as the TurboCell. Failure to properly install the flow switch can result in explosive gases accumulating in the pool plumbing system.

IMPORTANT: There must be at least a 12" (30cm) straight pipe run before (upstream) the flow switch. If the switch is plumbed after the cell, the cell can be counted as the 12" (30cm) of straight pipe.

IMPORTANT: To ensure proper operation, verify that the arrow on the flow switch points in the direction of water flow.

Electrical Wiring

The OmniLogic requires both high and low voltage connections. Low voltage connections will be made to actuators, sensors, remote keypad, etc. High voltage connections will be made to pumps, lights, etc., as well as providing direct input power to the Control Center. Always:

- Ensure that Power is disconnected prior to performing any wiring
- Follow all local and NEC (CEC if applicable) codes
- Use copper conductors only
- Remove power to the OmniLogic subpanel before removing the deadfront

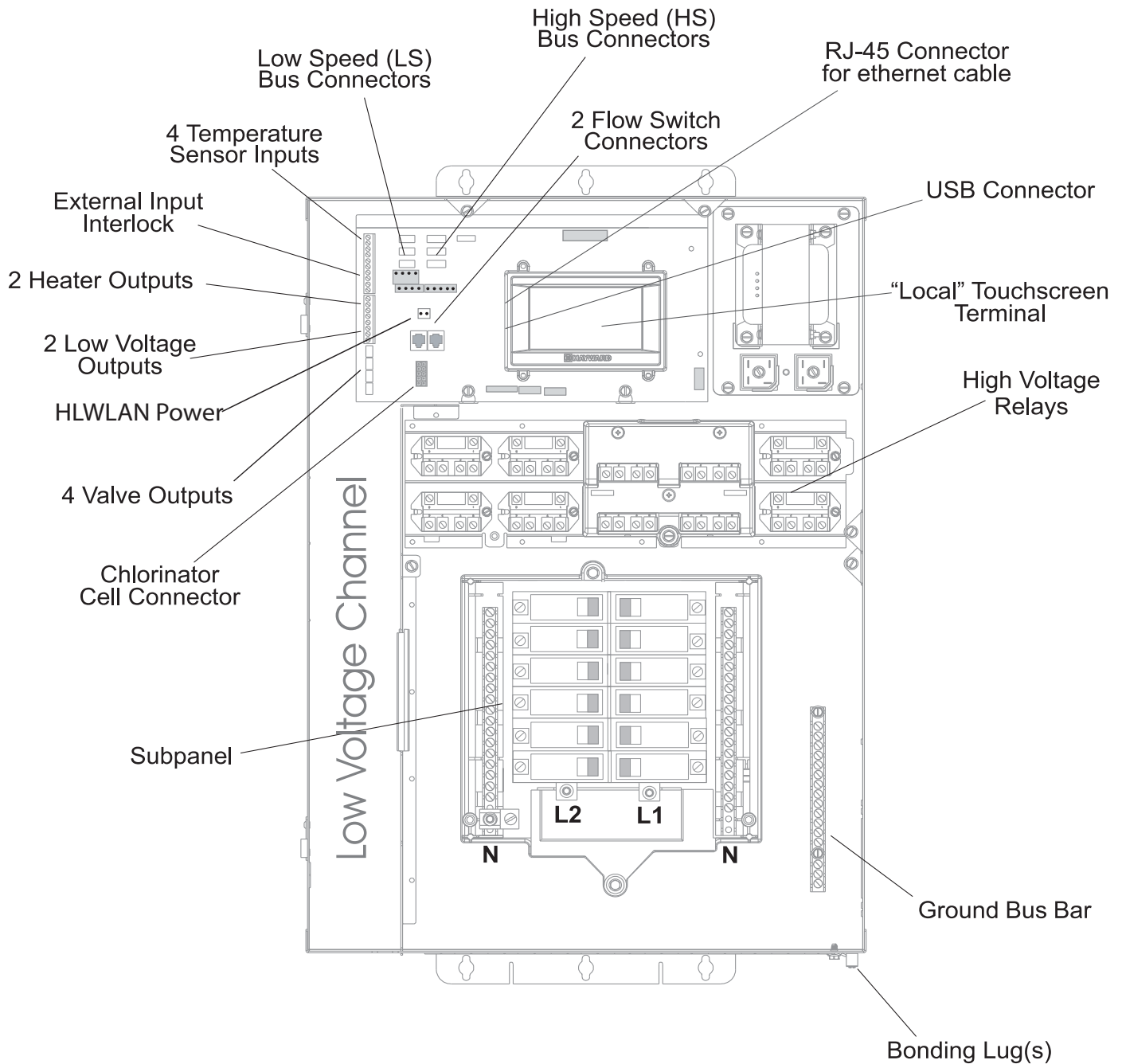



Main Service (Power to the Circuit Breaker Subpanel)

The OmniLogic circuit breaker subpanel can accommodate up to 12 circuit breakers and is rated for 125A service. Run properly rated conductors (L1, L2, N, and ground) from the primary house electrical panel to the main power connections on the OmniLogic circuit breaker base. The connection at the main house panel should be to a 240VAC circuit breaker rated at 125A maximum.

Grounding and Bonding

Connect a ground wire from the primary electrical panel to the OmniLogic ground bus bar. Also ground each piece of high voltage (120 or 240VAC) equipment that is connected to the OmniLogic control relays or circuit breakers. The OmniLogic should also be connected to the pool bonding system by an 8AWG (6AWG for Canada) wire. A lug for bonding is provided on the outside/bottom of the OmniLogic enclosure.

Circuit Breaker Installation and Wiring

Circuit breakers are to be supplied by the installer. Refer to the circuit breaker chart below for a list of suitable circuit breakers that can be used. Follow the code and the circuit breaker manufacturer's rating requirements regarding the size and temperature rating for wiring. Note that some pool equipment may be required to be connected to ground fault circuit breakers—check local and NEC (CEC) codes.

| SUITABLE LISTED BREAKERS | | | | | | | Tightening Torque |
|--------------------------|--------|--------|------|------|---------|---------------|-------------------|
| Manufacturer | Single | Double | Twin | Quad | GFCB | Filler Plates | |
| Cutler-Hammer | BR | BR | BRD | BRD | | BRFP | 25lb-in |
| Murray | MP-T | MP-T | MH-T | MH-T | MP-GT | LX100FP | 25lb-in |
| Siemens | QP | QP | QT | QT | QPF | QF3 | 25lb-in |
| Square D | HOM | HOM | HOMT | HOMT | HOM-GFI | HOMFP | 25lb-in |

General Purpose Outlet

If desired, a duplex receptacle with weatherproof cover (supplied by installer) may be installed in the knockout on the lower right side of the OmniLogic enclosure. Per code, use a GFCI type receptacle or a standard receptacle protected by a Ground Fault Circuit Breaker.

OmniLogic Power

The OmniLogic requires 120VAC, 5A power to operate the control logic circuits and the chlorinator. This power should be connected to a dedicated circuit breaker.

⚠ WARNING: 120VAC only (permanent damage will occur if connected to 240V)

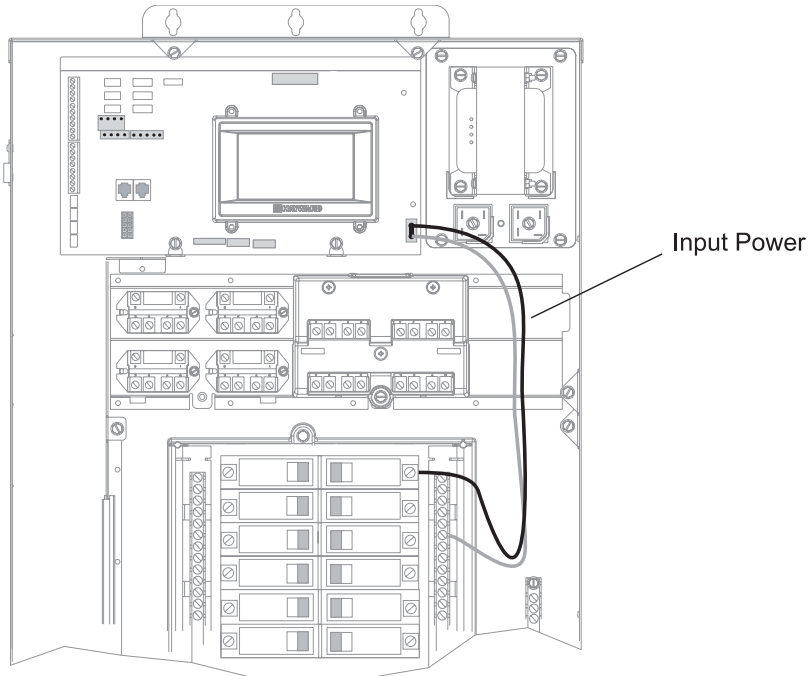

Connection Table

The HLBASE includes 4 high voltage relays, 4 low voltage/heater relays, 4 valve outputs and 4 temperature sensor inputs. Additional relays and inputs/outputs can be added using an HLRELAYBANK, HLIOEXPAND or HLRELAY(s) (see Accessories) . When wiring pool equipment to the OmniLogic, keep a record of all connections. You'll need to record which input/output is used and what equipment is attached. To aid in this process, use the table below. To identify the various inputs/outputs, refer to the diagram on the side of the table. After attaching a equipment to the OmniLogic, fill in the appropriate information in the table.

Connection Table

| Connection | Pool Equipment | Description |
|---------------------|----------------|-------------|
| High Voltage Relays | | |
| HVR1 | | |
| HVR2 | | |
| HVR3 | | |
| HVR4 | | |
| HVR5 | | |
| HVR6 | | |
| HVR7 | | |
| HVR8 | | |
| HVR9 | | |
| HVR10 | | |

| Low Voltage Relays/Heaters | | |
|----------------------------|--|--|
| LVR1 | | |
| LVR2 | | |
| LVR3 | | |
| LVR4 | | |
| LVR5 | | |
| LVR6 | | |
| LVR7 | | |
| LVR8 | | |

| Valve Actuators | | |
|-----------------|--|--|
| VLV1 | | |
| VLV2 | | |
| VLV3 | | |
| VLV4 | | |
| VLV5 | | |
| VLV6 | | |
| VLV7 | | |
| VLV8 | | |

| Temperature Sensors | | |
|---------------------|--|--|
| SENS1 POOL | | |
| SENS2 AIR | | |
| SENS3 SOLAR | | |
| SENSE4 EXT INP | | |
| SENS5 DE SPA | | |
| SENS6 | | |
| SENS7 | | |
| SENS8 | | |
| SENS9 | | |

- When using Optional HLIOEXPAND
- When using Optional HLRELAYBANK
- When using Optional HLRELAY(s)

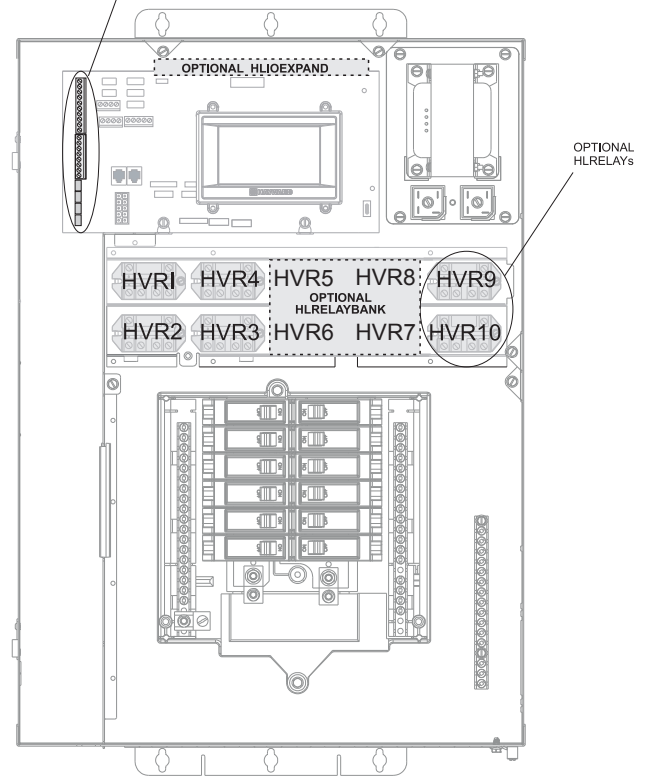
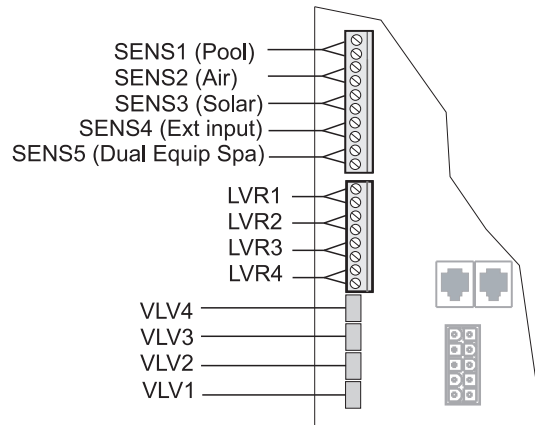

High Voltage Wiring

High Voltage Relays - (120/240V) Pool Equipment

All OmniLogic relays are double pole (they make/break both "legs" of 240V circuits) and are rated at 3HP/30A at 240V (1½HP/30A at 120V). Refer to the diagram below for typical relay wiring. Record all connections using the table on page 12.

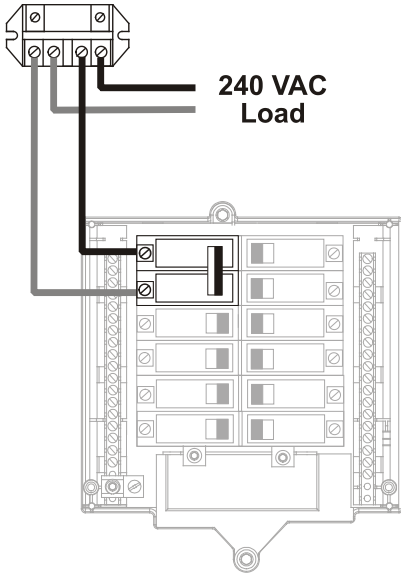

Wiring relays for 240 VAC Pool Equipment

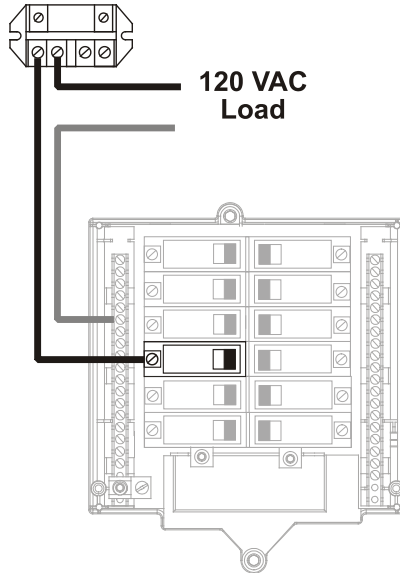

Wiring relays for 120 VAC Pool Equipment

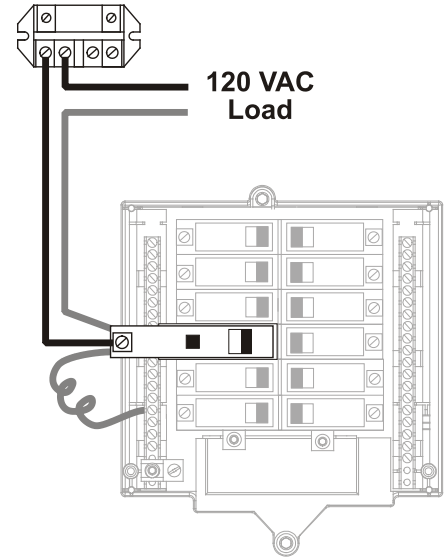

Wiring GFCB for 120 VAC Pool Equipment

⚠ WARNING: Do not use the OmniLogic to control an automatic pool cover. Swimmers may become entrapped underneath the cover.

⚠ WARNING: Do not use the OmniLogic to control fire pits or fire features.

Two speed filter pump

Requires two relays for proper operation of both speeds. NOTE: When selecting relays for two speed operation, note that both relays must be within the Relay Bank (HLRELAYBANK) or neither relay should be within the Relay Bank. The diagram below shows the pump connected to relays *outside* of the Relay Bank.

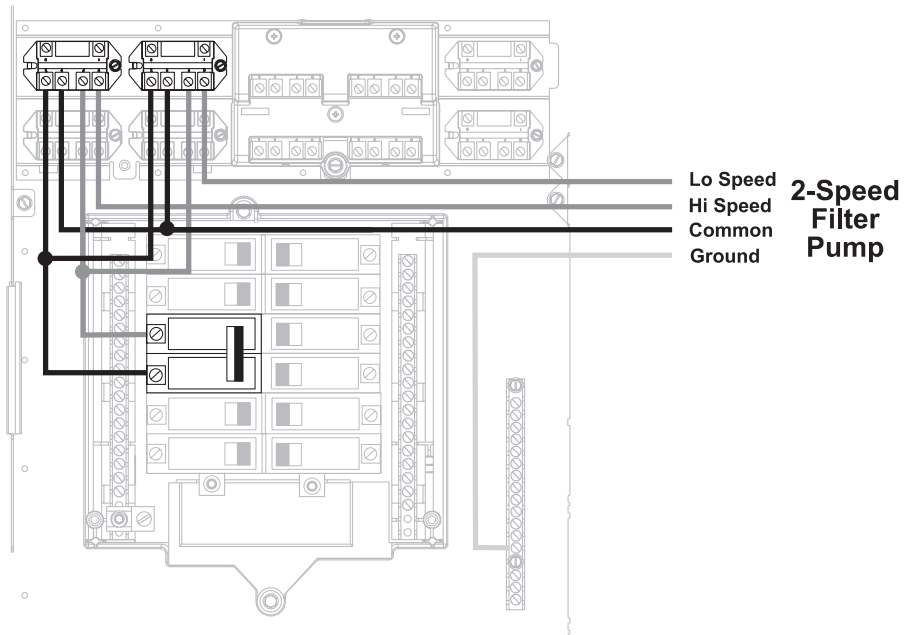



Lights
 A ground fault circuit breaker (GFCB) must be used to supply power for high voltage pool/spa lighting. Low voltage lights will require an external transformer. For lighting systems that have both a light source and color wheel, connect the light source to one relay and then connect the color wheel to a different relay.

Universal ColorLogic Lights (UCL): Multiple UCLs must be wired to the same relay if synchronization is desired. Refer to your ColorLogic manual for more information.

Hayward Variable Speed Pump
 Proper installation of a Hayward Variable Speed Pump (VSP) includes high voltage input wiring, low voltage communication wiring, and menu configuration/settings. The OmniLogic can control up to 16 EcoStar VSPs without the use of a relay. Refer to the diagram below for proper 220VAC input wiring to the VSP. Refer to “Low Voltage Wiring” section in this manual for information on communication wiring. Refer to the VSP manual(s) for detailed wiring information.

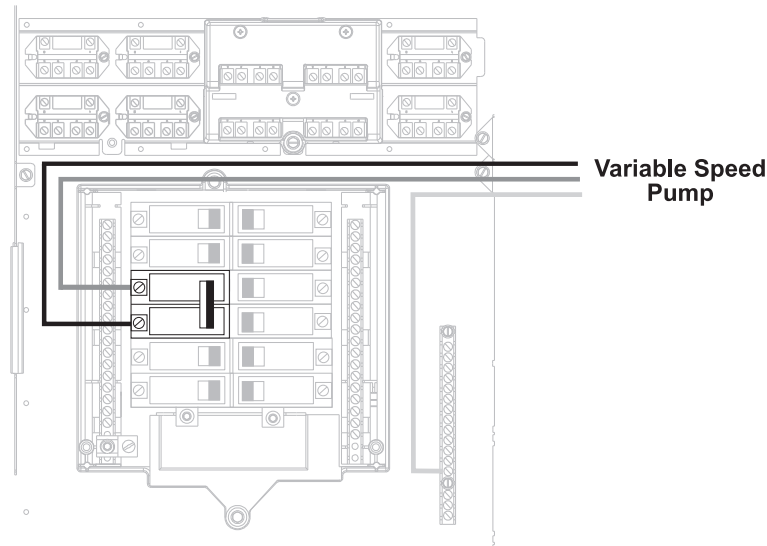

pH Dispense Output
 When used with a Hayward HL-CHEM, a pH dispensing device may be used. The HL-CHEM is an ORP and pH sensing kit that is offered as an accessory for OmniLogic pool automation controls. The HL-CHEM continuously tests the pool’s sanitization and pH levels allowing the OmniLogic to automatically generate the correct amount of chlorine and dispense the proper amount of pH reducer. Together, they provide an automated system controlling both sanitization and pH balance. Refer to the HL-CHEM’s owner’s manual for detailed pH dispense wiring instructions.

Low Voltage Wiring

Hayward Variable Speed Pump (VSP) Wiring
 Hayward VSPs connect to the OmniLogic’s Low Speed Bus. Refer to your EcoStar manual for proper low voltage communication wiring between the OmniLogic and the Hayward Variable Speed Pump.

Valve Actuators
 The OmniLogic HLBASE can control up to four automatic valve actuators. When used with the optional Input/Output Expander Board (HLIOEXPAND), up to 8 valve actuators can be used. Two of the valve outputs are normally used for the pool/spa suction (Valve2) and return (Valve1) valves. Valve3 and Valve4 are for general purpose use (solar, water feature, in-floor cleaner, etc.). All valve outputs on the HLIOEXPAND can be used in any manner.

For installations with solar heating, Hayward offers the AQ-SOL-KIT-xx solar kit that contains a valve, actuator, and extra temperature sensor. The “xx” indicates the valve type from the 2 choices below:

- 1P 1.5” Positive Seal
- 2P 2” Positive Seal

The OmniLogic is compatible with standard valve actuators manufactured by Hayward, Pentair/Compool, and Jandy. Actuators will connect to the VLV outputs on the Main Board. Refer to the diagram on page 12 for the location of valve connectors (VLV) on the OmniLogic Main Board. Record all connections in the Connection Table on page 12.



Heater Control

The HLBASE OmniLogic provides a set of 4 low voltage dry contacts that can be connected to most gas heaters or heat pumps with 24V control circuits. When used with the optional Input/Output Expander Board (HLIOEXPAND), 8 dry contact relays are available. Refer to the diagram below for a generic heater connection. The manuals supplied with most heaters also include specific wiring instructions for connecting the heater to an external control (usually identified as "2-wire" remote control). For millivolt or line voltage heaters, contact Hayward Tech support, 908-355-7995. Refer to the information on the following pages for more details on the connection to several popular heaters. Refer to the diagram on page 12 for the location of heater connections (LVR) on the OmniLogic Main Board. Record all connections in the Connection Table.

Generic Heaters

1. Wire heater to 120/240V power source per the instructions in the heater manual. The OmniLogic does NOT control the power going to the heater.
2. Wire the OmniLogic dry contact heater output per the diagram below. Many internal parts of the heater can get very hot--see the heater manufacturer's recommendations on the minimum temperature rating for wires. If no guidance is given, use 105°C rated wire.
3. Set any ON/OFF switch on the heater to ON.
4. Set the thermostat(s) on the heater to the maximum (hottest) setting.

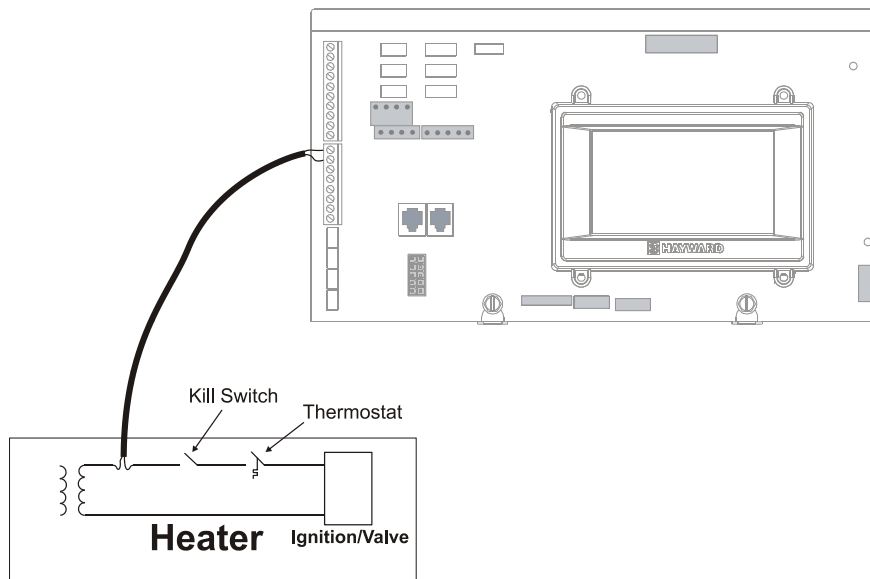

Laars Heaters

1. Turn power off to heater.
2. Remove factory jumper from terminal block.
3. Wire OmniLogic to the heater as shown.
4. Ensure toggle switch is in the ON position.
5. Set heater thermostats to maximum position.

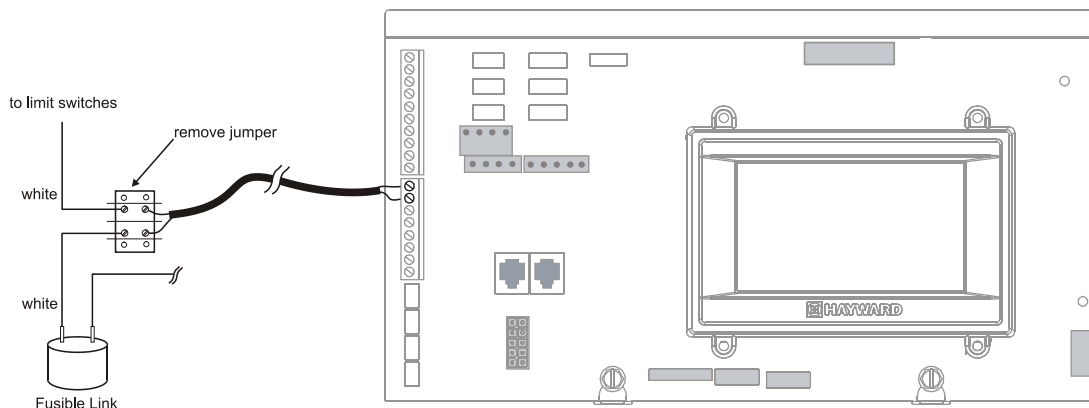

Hayward Pre-2007 Heaters

Refer to the instructions in the heater manual for “2-wire Remote Thermostat” operation under “Remote Control Connections” and the diagram below:

1. Turn off power to heater.
2. Wire OmniLogic to terminals 1 & 2 (see diagram).
3. Leave jumper attached to terminals 4 & 5.
4. Move “BYPASS” dipswitch on heater circuit board to “ON” position (up).
5. Turn heater power back on.
6. Switch heater to either “Pool” or “Spa” (it doesn’t make any difference which is selected, the OmniLogic will take control).
7. Heater display should be “b0” (for “bypass On”).
8. Heater will start whenever OmniLogic requests (when OmniLogic “Heater” LED is illuminated).

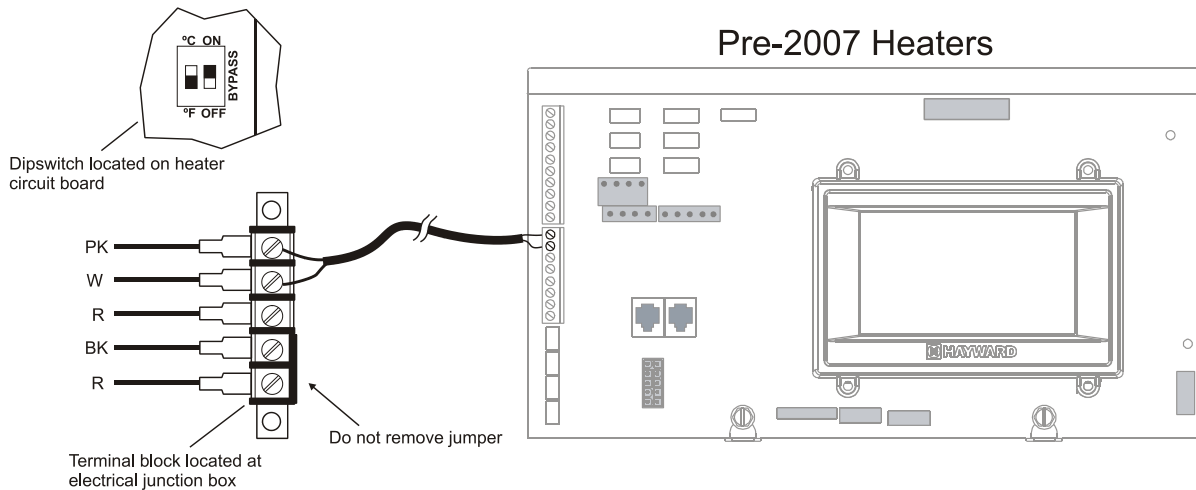

Hayward 2007-Current Heaters

Refer to the instructions in the heater manual for “2-wire Remote Thermostat” operation under “Remote Control Connections” and the diagram below:

1. Turn off power to heater.
2. Wire OmniLogic to the heater terminals that have the Orange & White connections (see diagram).
3. Turn heater power back on.
4. Use the “MODE” key on the heater keypad to put the control into “STANDBY” mode.
5. Press and hold both the “DOWN” and “MODE” keys for 3 seconds until the display shows the code “bo”.
6. Be sure to put the heater’s control in either “POOL” or “SPA” mode.
7. The OmniLogic will now control the heater.

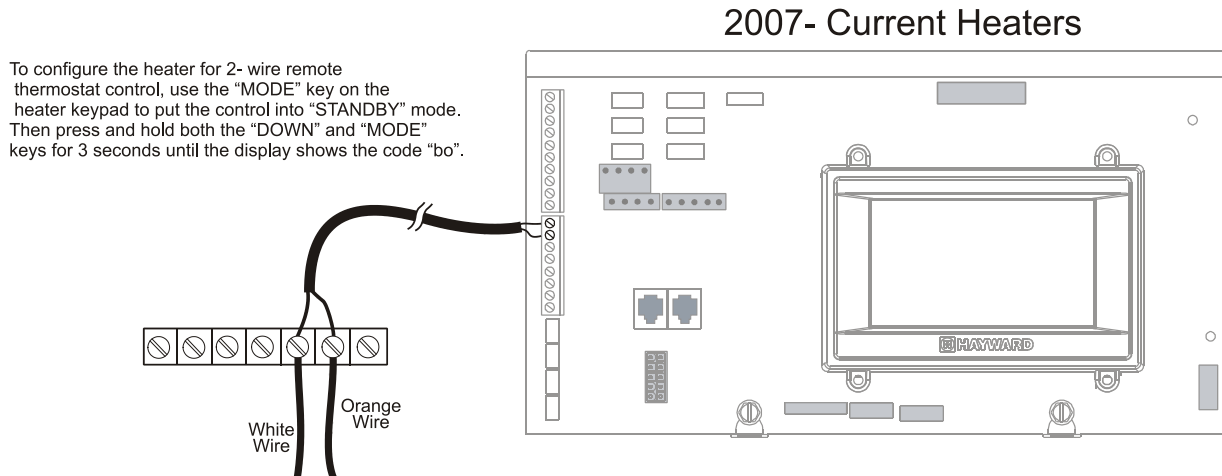



Pentair/Purex/MiniMax

1. Turn power off to heater.
2. Remove factory installed jumper from the "Ext Switch" connector.
3. Wire OmniLogic to the "Ext Switch" connector as shown below.
4. The wires to the OmniLogic must be separated from any line voltage wires. Failure to follow these instructions may cause erratic operation of the heater.
5. Set the Power (Thermostat Select) switch to either "Pool" or "Spa".
6. Set the "Pool" and "Spa" thermostats to their maximum settings.

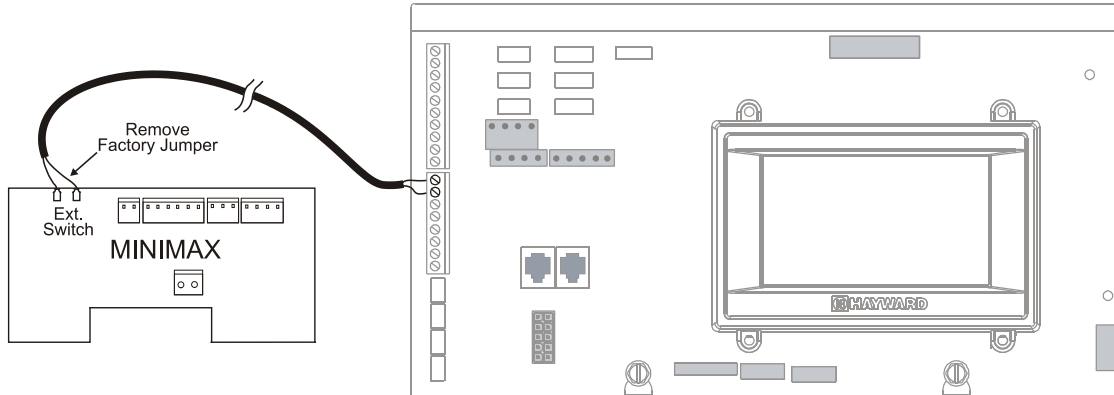

Raypak RP2100 Pool/Spa Heater

1. Turn power off to heater.
2. Push the mode button to "spa" mode.
3. Set the temperature to the maximum.
4. Push the mode button to "OFF".
5. Lastly, plug the prewired connector in the P7 position on the board.

IMPORTANT: The heater will display "OFF" when it is being remotely controlled by the OmniLogic. Some homeowners see the "OFF" display and, thinking this is a mistake, change the mode to "POOL" or "SPA" which then disables the remote control by the OmniLogic. To prevent this: Remove the heater touch pad connector (P5) which will disable the touchpad.

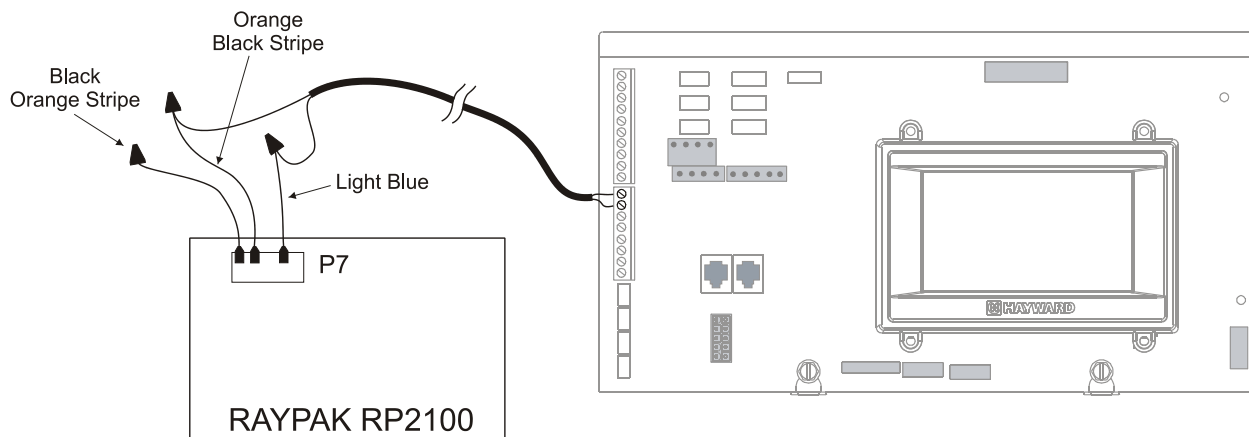

STA-RITE Heater

1. Turn power off to heater.
2. Remove upper jacket and open the control box.
3. Remove the jumper for the "fireman's switch".
4. Wire to the OmniLogic using wire rated for 105°C minimum.

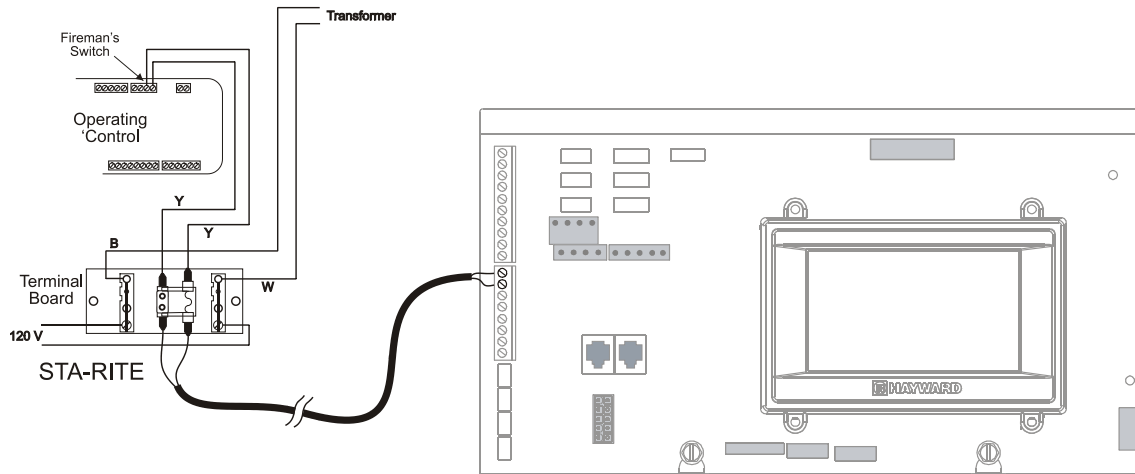

Temperature Sensors

The OmniLogic utilizes 10K ohm thermistor type sensors and provides three inputs. Three sensors (water temperature, air temperature and solar or dual equipment spa temperature) are included. If the OmniLogic is being used to control a solar heating system, the solar sensor is required. If dual equipment will be used, the dual equipment spa sensor is required. If both solar and dual equipment are desired, another temperature sensor must be purchased separately. The sensors are provided with a 15 ft. cable. If a longer cable is required, contact the Hayward service dept. (908-355-7995) for information on suitable cable types and splices. Wire sensors as shown below. Record all connections using the table on page 12.

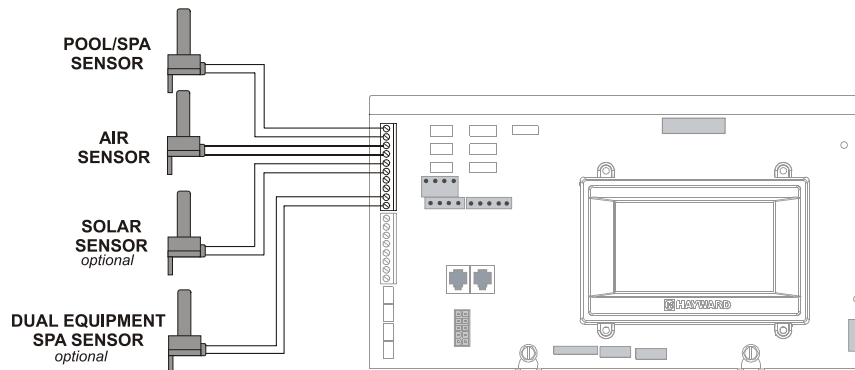

External Input Interlock

The External Input Interlock provides a means to turn the filter pump or other component on/off when certain conditions exists. A normally open or normally closed on/off external device must be connected to the OmniLogic as shown below. After properly configuring the OmniLogic (see Configuration Wizard in Operation Manual), the filter pump and/or desired pool component will be forced on or off when the device is active. Record all connections using the table on page 12.

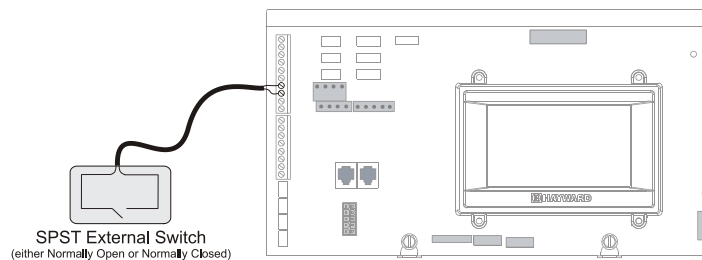

Remote Terminal

Up to 2 wired HLWALLMOUNT touchscreen remote terminals can be wired to the OmniLogic. Use 24 AWG (or better) four conductor cable (typically phone cable) to connect the wired remote terminal to the OmniLogic's High Speed Bus as shown below. Note that the screw connections on both the OmniLogic main unit and the wired remote terminal are numbered: Connect 1 to 1, 2 to 2, etc. as shown in the diagram below. Although the High Speed Bus has 5 screw terminals, screw #5 is not used. Refer to the HLWALLMOUNT manual for maximum distances and complete installation instructions.

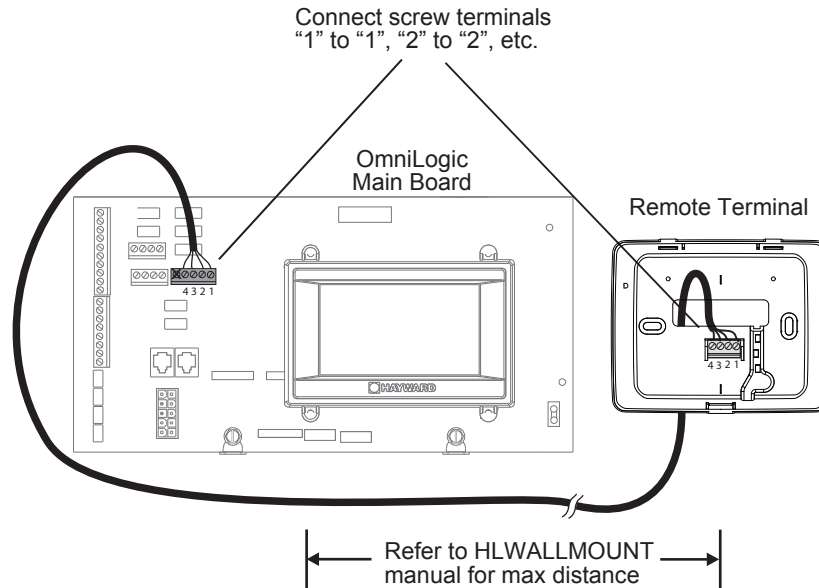

HL-CHEM ORP and pH Sensing Kit

Plug in the connector from the HL-CHEM into one of the Low Speed Bus connectors on the main PCB in the OmniLogic Control Center as shown below. Refer to the HL-CHEM manual for complete installation instructions.

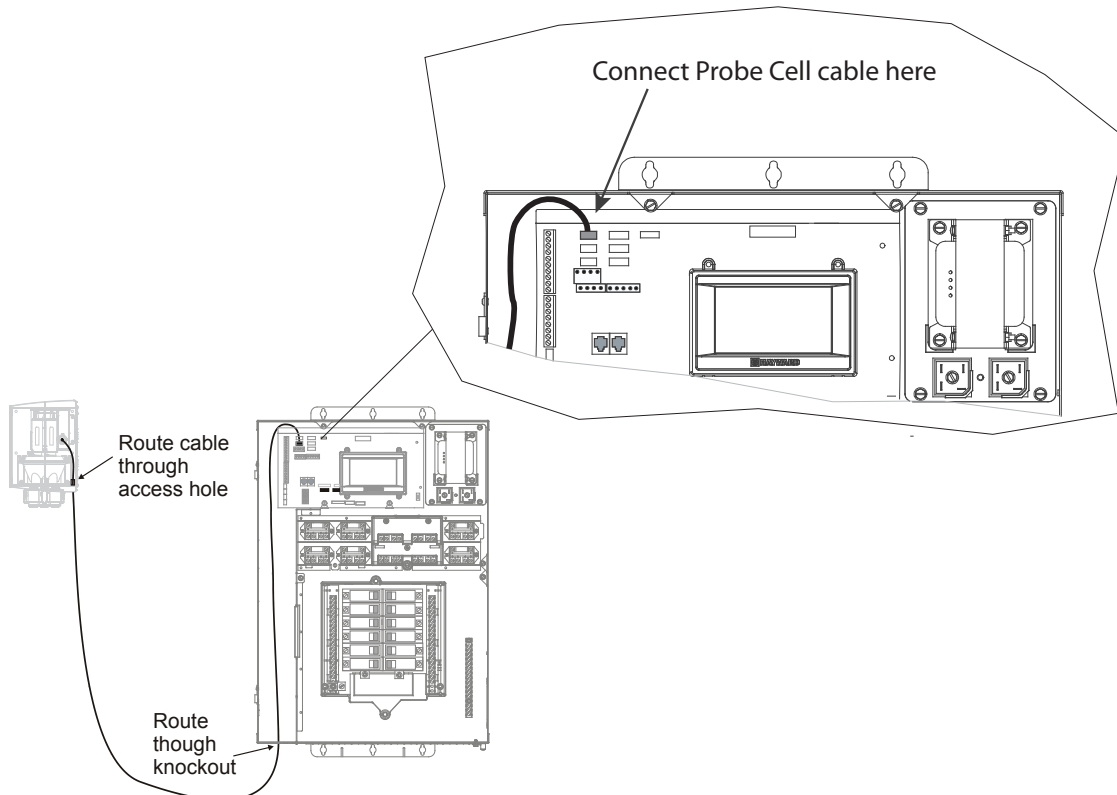

Home Router

Connection to the web is optional. If web enabled devices such as a PC, laptop, tablet or phone will be used to access the OmniLogic, an ethernet connection must be made to the home router. Use outdoor rated Cat5e or Cat6 ethernet cable and run a loop through the supplied ferrite bead as shown in the diagram. Connect one end to the OmniLogic and the other to an available LAN port (not WAN) on the home router.

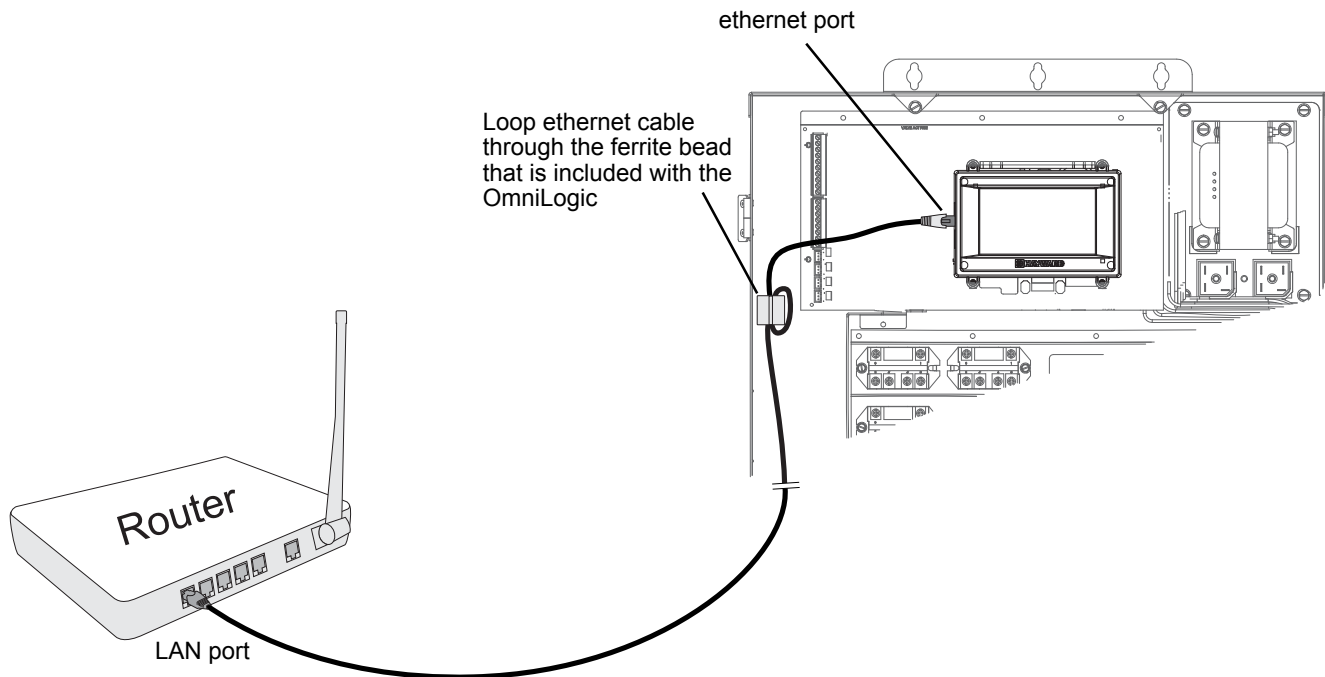

Flow Switch

Only applicable if the chlorinator function is enabled and/or if an optional HL-CHEM will be used. The flow switch cable plugs into the flow switch connector on the OmniLogic's Main Board as shown on page 10. Ensure that the connector catch "snaps" in order to provide a reliable connection.

TurboCell

Only applicable if the chlorinator function is enabled. The TurboCell should be plugged in AFTER the OmniLogic cover panel is installed. Refer to page 10 for the location of the chlorinator cell connector.

HLIOEXPAND

The HLIOEXPAND is design to slide between guide rails and insert into a dedicated slot on the OmniLogic main board. At startup, the OmniLogic will discover the HLIOEXPAND and its inputs/outputs can be configured within the OmniLogic's CONFIGURATION WIZARD. Refer to the HLIOEXPANDER manual for installation instructions.

HLRELAYBANK

Offering four additional high voltage relays, the HLRELAYBANK is a relay kit accessory designed to install next to the four on-board relays in the HLBASE. After installing the HLRELAYBANK, a wire connection must be made at the OmniLogic Main Board. At startup, the OmniLogic will detect the HLRELAYBANK and allow the user to configure the additional relays in the CONFIGURATION WIZARD. Refer to the HLRELAYBANK manual for installation instructions.

HLRELAY

The HLRELAY is a single high voltage relay designed to be mounted in the #9 and/or #10 positions near the four on-board relays. After installing the HLRELAY, a wire connection must be made at the OmniLogic Main Board. At startup, the OmniLogic will detect the HLRELAY and allow the user to configure the additional relay(s) in the CONFIGURATION WIZARD. Refer to the HLRELAY manual for installation instructions.

HLWLAN

The HLWLAN can be mounted up to 25ft away from the OmniLogic and requires an ethernet connection to the OmniLogic as well as a power connection to the OmniLogic's Main Board. Refer to the HLWLAN manual for detailed installation instructions.



Preparing Pool/Spa Water

Chlorination

When used with an optional Hayward TurboCell and P-KIT, the OmniLogic can generate all the chlorine needs for pools up to 40,000 gallons (150,000 liters), or the needs of most commercial pools up to 25,000 gallons (95,000 liters). If enabled (see Configuration Wizard), this operation requires a low concentration of salt (sodium chloride) in the pool/spa water. The OmniLogic automatically converts salt into free chlorine which kills bacteria and algae in the pool/spa. Chlorine will revert back to sodium chloride after killing bacteria. These reactions will continuously recycle, virtually eliminating the need to add sanitizing chemicals to your pool/spa. The only time you may need to add more salt to the pool/spa is when water is replenished due to backwashing, draining, or splashing (not evaporation). The actual amount of chlorination required to properly sanitize a pool varies due to bather load, rainfall, temperature, and the pool's cleanliness.

General Water Chemistry

Salt is required only if you are using the chlorinator features on the OmniLogic Control Center. If you are NOT using the chlorinator, it is recommended that you follow all of the other chemistry recommendations besides salt.

Water Chemistry

This table summarizes the levels that are recommended by the Association of Pool and Spa Professionals (APSP). The only special requirements for the OmniLogic are the salt level and stabilizer.

| CHEMICAL | IDEAL LEVELS |
|----------------------------|--------------------|
| Salt | 2700 to 3400 ppm |
| Free Chlorine | 1.0 to 3.0 ppm |
| pH | 7.2 to 7.8 |
| Cyanuric Acid (Stabilizer) | 30 to 50 ppm |
| Total Alkalinity | 80 to 120 ppm |
| Calcium Hardness | 200 to 400 ppm |
| Metals | 0 ppm |
| Saturation Index | -.2 to .2 (0 best) |

Saturation index

The saturation index (Si) relates to the calcium and alkalinity in the water and is an indicator of the pool water "balance". Your water is properly balanced if the Si is 0 ± 0.2 . If the Si is below -0.2 , the water is corrosive and plaster pool walls will be dissolved into the water. If the Si is above $+0.2$, scaling and staining will occur. Use the chart below to determine the saturation index.

$$Si = pH + Ti + Ci + Ai - TDS$$

| °C | °F | Ti | Hardness Calcium | Ci | Total alkalinity | Ai | Total Dissolved Solids | TDS |
|----|-----|-----|------------------|-----|------------------|-----|------------------------|-------|
| 12 | 53 | 0.3 | 75 | 1.5 | 75 | 1.9 | 0-1000 | 12.10 |
| 16 | 60 | 0.4 | 100 | 1.6 | 100 | 2.0 | 1001-2000 | 12.29 |
| 19 | 66 | 0.5 | 125 | 1.7 | 125 | 2.1 | | |
| 24 | 76 | 0.6 | 150 | 1.8 | 150 | 2.2 | 2001-3000 | 12.35 |
| 29 | 84 | 0.7 | 200 | 1.9 | 200 | 2.3 | | |
| 34 | 94 | 0.8 | 250 | 2.0 | 250 | 2.4 | 3001-4000 | 12.41 |
| 39 | 102 | 0.9 | 300 | 2.1 | 300 | 2.5 | | |
| | | | 400 | 2.2 | 400 | 2.6 | 4001-5000 | 12.44 |
| | | | 600 | 2.4 | 600 | 2.8 | | |
| | | | 800 | 2.5 | 800 | 2.9 | | |

Use: Measure the pH of the pool water, the temperature, water hardness, total alkalinity, and total dissolved solids. Use the table above to determine Ti, Ci, Ai, and TDS in the formula shown above. If the Si is equal to 0.2 or more, stains may appear. If the Si is equal to -0.2 or less, corrosion or deterioration may occur.

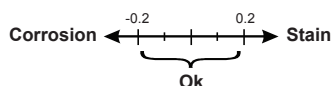



The pool's chemistry must be balanced BEFORE activating the OmniLogic's optional chlorinator function. NOTE: If the pool does not have new water, add metal remover and non-copper based algaecide to the pool, per manufacturer's instructions. This ensures a quick, troublefree transfer to the OmniLogic system.

Salt (When using optional chlorinator function)

Use the chart on the following page to determine how much salt in pounds or (Kgs) should be added to reach the recommended levels. Use the Pool Sizing Formula below (measurements are in feet/gallons and meters/liters) if pool size is unknown.

| | Gallons (pool size in feet) | Liters (pool size in meters) |
|--------------------|--|--|
| Rectangular | Length x Width x Average Depth x 7.5 | Length x Width x Average Depth x 1000 |
| Round | Diameter x Diameter x Average Depth x 5.9 | Diameter x Diameter x Average Depth x 785 |
| Oval | Length x Width x Average Depth x 6.7 | Length x Width x Average Depth x 893 |

The operating salt level is between 2700-3400 PPM (parts per million) with 3200 PPM being optimal. Before adding any salt, test the salt level. This is especially important for retrofit installation to older pools where all of the chlorine added to the pool over time is ending up as salt. If the level is low, determine the number of gallons in the pool and add salt according to the chart below. A low salt level will reduce the efficiency of the sanitization and result in low chlorine production. A high salt level can cause the OmniLogic to stop chlorinating. The salt in your pool/spa is constantly recycled and the loss of salt throughout the swimming season should be minimal. This loss is due primarily to the addition of water because of splashing, backwashing, or draining (because of rain). Salt is not lost due to evaporation.

POUNDS and (Kg) OF SALT NEEDED FOR 3200 PPM

| Current salt level ppm | Gallons and (Liters) of Pool/Spa water | | | | | | | | | | | | | | | | |
|------------------------|--|--------------------|--------------------|--------------------|--------------------|--------------------|--------------------|--------------------|--------------------|--------------------|---------------------|---------------------|---------------------|---------------------|---------------------|---------------------|---------------------|
| | 8,000 (30,000) | 10,000 (37,500) | 12,000 (45,000) | 14,000 (52,500) | 16,000 (60,000) | 18,000 (67,500) | 20,000 (75,000) | 22,000 (82,500) | 24,000 (90,000) | 26,000 (97,500) | 28,000 (105,000) | 30,000 (112,500) | 32,000 (120,000) | 34,000 (127,500) | 36,000 (135,000) | 38,000 (142,500) | 40,000 (150,000) |
| 0 | 213 (97) | 267 (121) | 320 (145) | 373 (170) | 427 (194) | 480 (218) | 533 (242) | 587 (267) | 640 (291) | 693 (315) | 747 (339) | 800 (364) | 854 (388) | 907 (412) | 960 (436) | 1013 (460) | 1067 (484) |
| 200 | 200 (91) | 250 (114) | 300 (136) | 350 (159) | 400 (182) | 450 (205) | 500 (227) | 550 (250) | 600 (273) | 650 (295) | 700 (318) | 750 (341) | 800 (363) | 850 (385) | 900 (408) | 950 (430) | 1000 (453) |
| 400 | 187 (85) | 233 (106) | 280 (127) | 327 (148) | 373 (170) | 420 (191) | 467 (212) | 513 (233) | 560 (255) | 607 (276) | 653 (297) | 700 (318) | 747 (339) | 793 (360) | 840 (382) | 887 (403) | 933 (424) |
| 600 | 173 (79) | 217 (98) | 260 (118) | 303 (138) | 347 (158) | 390 (177) | 433 (197) | 477 (217) | 520 (236) | 563 (256) | 607 (276) | 650 (297) | 693 (317) | 737 (337) | 780 (358) | 823 (378) | 867 (398) |
| 800 | 160 (73) | 200 (91) | 240 (109) | 280 (127) | 320 (145) | 360 (164) | 400 (182) | 440 (200) | 480 (218) | 520 (236) | 560 (255) | 600 (273) | 640 (291) | 680 (310) | 720 (328) | 760 (346) | 800 (364) |
| 1000 | 147 (67) | 183 (83) | 220 (100) | 257 (117) | 293 (133) | 330 (150) | 367 (167) | 403 (183) | 440 (200) | 477 (217) | 513 (233) | 550 (250) | 587 (267) | 623 (283) | 660 (300) | 697 (317) | 733 (333) |
| 1200 | 133 (61) | 167 (76) | 200 (91) | 233 (106) | 267 (121) | 300 (136) | 333 (152) | 367 (167) | 400 (182) | 433 (197) | 467 (212) | 500 (227) | 533 (243) | 567 (258) | 600 (274) | 633 (289) | 667 (304) |
| 1400 | 120 (55) | 150 (68) | 180 (82) | 210 (95) | 240 (109) | 270 (123) | 300 (136) | 330 (150) | 360 (164) | 390 (177) | 420 (191) | 450 (205) | 480 (218) | 510 (232) | 540 (246) | 570 (259) | 600 (263) |
| 1600 | 107 (48) | 133 (61) | 160 (73) | 187 (85) | 213 (97) | 240 (109) | 267 (121) | 293 (133) | 320 (145) | 347 (158) | 373 (170) | 400 (182) | 427 (195) | 453 (207) | 480 (219) | 507 (231) | 533 (243) |
| 1800 | 93 (42) | 117 (53) | 140 (64) | 163 (74) | 187 (85) | 210 (95) | 233 (106) | 257 (117) | 280 (127) | 303 (138) | 327 (148) | 350 (159) | 373 (169) | 397 (180) | 420 (190) | 443 (201) | 467 (211) |
| 2000 | 80 (36) | 100 (45) | 120 (55) | 140 (64) | 160 (73) | 180 (82) | 200 (91) | 220 (100) | 240 (109) | 260 (118) | 280 (127) | 300 (136) | 320 (145) | 340 (154) | 360 (163) | 380 (172) | 400 (181) |
| 2200 | 67 (30) | 83 (38) | 100 (45) | 117 (53) | 133 (61) | 150 (68) | 167 (76) | 183 (83) | 200 (91) | 217 (98) | 233 (106) | 250 (114) | 267 (121) | 283 (129) | 300 (137) | 317 (144) | 333 (152) |
| 2400 | 53 (24) | 67 (30) | 80 (36) | 93 (42) | 107 (48) | 120 (55) | 133 (61) | 147 (67) | 160 (73) | 173 (79) | 187 (85) | 200 (91) | 213 (98) | 227 (104) | 240 (110) | 253 (117) | 267 (123) |
| 2600 | 40 (18) | 50 (23) | 60 (27) | 70 (32) | 80 (36) | 90 (41) | 100 (45) | 110 (50) | 120 (55) | 130 (59) | 140 (64) | 150 (68) | 160 (73) | 170 (77) | 180 (81) | 190 (86) | 200 (90) |
| 2800 | 27 (12) | 33 (15) | 40 (18) | 47 (21) | 53 (24) | 60 (27) | 67 (30) | 73 (33) | 80 (36) | 87 (39) | 93 (42) | 100 (45) | 107 (48) | 113 (51) | 120 (54) | 127 (57) | 133 (60) |
| 3000 | 13 (6) | 17 (8) | 20 (9) | 23 (11) | 27 (12) | 30 (14) | 33 (15) | 37 (17) | 40 (18) | 43 (20) | 47 (21) | 50 (23) | 53 (24) | 57 (26) | 60 (27) | 63 (29) | 67 (30) |
| 3200 | Ideal | Ideal | Ideal | Ideal | Ideal | Ideal | Ideal | Ideal | Ideal | Ideal | Ideal | Ideal | Ideal | Ideal | Ideal | Ideal | Ideal |
| 3400 | OK | OK | OK | OK | OK | OK | OK | OK | OK | OK | OK | OK | OK | OK | OK | OK | OK |
| 3600+ | Dilute | Dilute | Dilute | Dilute | Dilute | Dilute | Dilute | Dilute | Dilute | Dilute | Dilute | Dilute | Dilute | Dilute | Dilute | Dilute | Dilute |



Type of Salt to Use

It is important to use only sodium chloride (NaCl) salt that is greater than 99.0% pure. This can be found at most pool stores in 40-80 lb. bags labeled “for use in swimming pools”. Alternatively, use common food quality or water softener salt that is at least 99.0% pure. It is also acceptable to use water conditioning salt pellets, however, it will take longer for them to dissolve. Do not use rock salt, or salt with more than 1% of yellow prussiate of soda, salt with anti-caking additives, or iodized salt.

How to Add Salt

For new plaster pools, wait 10-14 days before adding salt to allow the plaster to cure. Turn the circulating pump on and add salt directly into the pool. Brush the salt around to speed up the dissolving process—do not allow salt to pile up on the bottom of the pool. Run the filter pump for 24 hours with the suction coming from the main drain (use pool vacuum if there is no main drain) to allow the salt to evenly disperse throughout the pool. The salt display may take 24 hours to respond to the change in salt concentration.

Always check stabilizer (cyanuric acid), when checking salt. These levels will most likely decline together. Use the chart below to determine how much stabilizer must be added to raise the level to 40 ppm.

POUNDS and (Kg) OF STABILIZER (CYANURIC ACID) NEEDED FOR 40 PPM

| Current Stabilizer level (ppm) | Gallons and (Liters) of Pool Water | | | | | | | | | | | | | | | | |
|--------------------------------|------------------------------------|----------------|----------------|----------------|----------------|----------------|----------------|----------------|----------------|----------------|-----------------|-----------------|-----------------|-----------------|-----------------|-----------------|-----------------|
| | 8,000 (30000) | 10,000 (37500) | 12,000 (45000) | 14,000 (52500) | 16,000 (60000) | 18,000 (67500) | 20,000 (75000) | 22,000 (82500) | 24,000 (90000) | 26,000 (97500) | 28,000 (105000) | 30,000 (112500) | 32,000 (120000) | 34,000 (127500) | 36,000 (135000) | 38,000 (142500) | 40,000 (150000) |
| 0 ppm | 2.7 (1.2) | 3.4 (1.5) | 4.0 (1.8) | 4.7 (2.2) | 5.4 (2.5) | 6.0 (2.7) | 6.7 (3.0) | 7.4 (3.4) | 8.0 (3.6) | 8.7 (4.0) | 9.4 (4.3) | 10.0 (4.5) | 10.8 (5.0) | 11.4 (5.2) | 12 (5.4) | 12.7 (5.7) | 13.4 (6) |
| 10 ppm | 2.0 (.9) | 2.5 (1.1) | 3.0 (1.4) | 3.5 (1.6) | 4.0 (1.8) | 4.5 (2.0) | 5.0 (2.3) | 5.5 (2.5) | 6.0 (2.7) | 6.5 (3.0) | 7.0 (3.2) | 7.5 (3.4) | 8 (3.6) | 8.5 (3.8) | 9 (4.0) | 9.5 (4.3) | 10 (4.6) |
| 20 ppm | 1.3 (.59) | 1.7 (.77) | 2.0 (.90) | 2.3 (1.1) | 2.7 (1.3) | 3.0 (1.3) | 3.3 (1.5) | 3.7 (1.6) | 4.0 (1.8) | 4.3 (2.0) | 4.6 (2.1) | 4.9 (2.2) | 5.4 (2.4) | 5.7 (2.5) | 6 (2.6) | 6.3 (2.8) | 6.6 (3.0) |
| 30 ppm | 0.7 (.31) | 0.8 (.36) | 1.0 (.45) | 1.2 (.54) | 1.4 (.64) | 1.5 (.68) | 1.7 (.77) | 1.8 (.82) | 2.0 (.91) | 2.2 (.97) | 2.4 (1.1) | 2.6 (1.2) | 2.8 (1.3) | 2.9 (1.3) | 3.0 (1.4) | 3.2 (1.4) | 3.4 (1.5) |
| 40 ppm | 0.0 | 0.0 | 0.0 | 0.0 | 0.0 | 0.0 | 0.0 | 0.0 | 0.0 | 0.0 | 0.0 | 0.0 | 0.0 | 0.0 | 0.0 | 0.0 | 0.0 |

System Startup

Before Startup

Before starting the OmniLogic for the first time, be sure that the following items have been completed:

1. Pool/spa chemicals are within the recommended levels according to the chart on page 21.
2. If using chlorinator function, pool/spa salt level is between 2700 – 3400 PPM.
3. Properly rated circuit breakers are installed in the OmniLogic subpanel.
4. All wiring is performed according to NEC and local codes.
5. The OmniLogic is properly grounded and bonded.

Firmware Upgrade

The OmniLogic’s firmware is the basic operating system that runs the unit. The OmniLogic was shipped with the version of firmware that was available at the time of release. There may be a newer version available and if so, we encourage you to upgrade. Also, if you have experienced problems, Hayward Technical Support may advise you to upgrade your OmniLogic firmware. To upgrade the OmniLogic firmware, refer to the procedure shown in the OmniLogic Operation Manual. Upgrading firmware can be performed before or after Configuration but should be done before the OmniLogic begins operation.



Configuration

Initial Configuration

When all input and pool related wiring is complete, replace and secure the deadfront. The OmniLogic can now be powered on for the first time. Apply power at the main panel and wait for the OmniLogic to completely start. This may take a full minute or two. Because this is the first time that the OmniLogic has been powered on, it will bring you directly to the initial configuration screen shown below. Note that the OmniLogic uses a resistive touchscreen that is appropriate for a pool environment. It requires a deliberate push when selecting a button. At the initial configuration screen, touch the Configuration Wizard button in the center of the screen. On the following screen, touch the Configuration Wizard button as shown below.

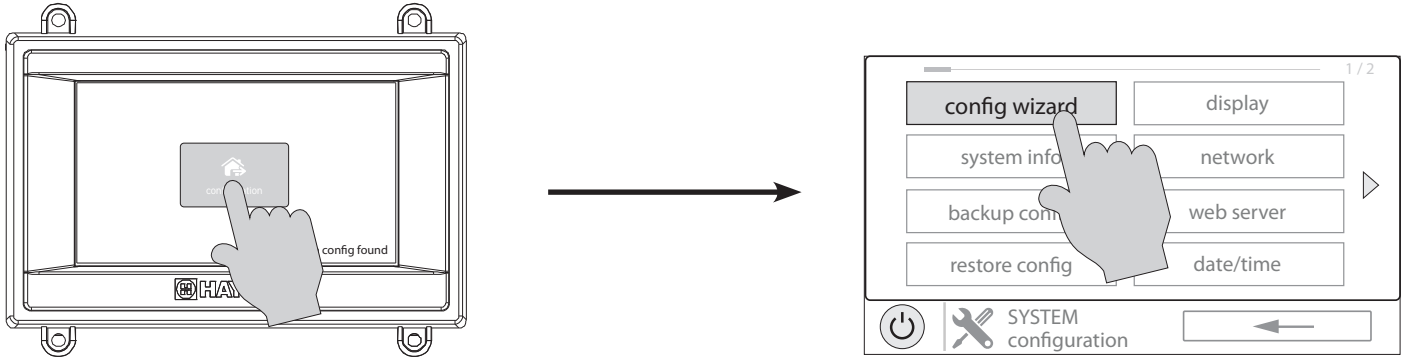







About the Configuration Wizard

The OmniLogic uses a Configuration Wizard to assist in the configuration of the OmniLogic. The Configuration Wizard will ask you general questions relating to your pool/spa and specific questions about connected pool equipment. Because this process may take some time, do not begin to configure the OmniLogic unless you can dedicate at least 15 minutes or more. Configuring the OmniLogic requires knowledge of all of the connected pool equipment so have the Connection Table (page 12) handy while configuring the OmniLogic.

If you are asked a question and don't know the answer, in many cases you'll be able to skip the question and proceed. In some cases the Configuration Wizard will require an answer. Answer the question to the best of your ability and take note as you'll be able to go back into the Configuration Wizard at a later time to make changes.

Navigation

The Configuration Wizard has been designed to be intuitive allowing most users the ability to navigate with little instruction. Below, a list of commonly used buttons are explained..

-  **Done** - Touch this button to complete your selection.
-  **Cancel** - Touch this button to cancel your selection.
-  **Advance** - Touch this button to advance to the next screen.
-  **Back** - Touch this button to return to the previous screen.
-  **Add** - Touch this button to add an item
-  **Delete** - Touch this button to delete a highlighted item.

After being prompted to make a selection or answer a question, touch the Done button (if available) and then the Advance button to go to the next screen. To go back to a previous screen, touch the Back button. Many selections will require you to touch the Done button before allowing you to advance. If a wrong selection has been made, touch the Delete button or Cancel. Some settings can be made by sliding a bar left or right to decrease or increase a value. You may be required to assign names to equipment. In this case, a keyboard will be displayed and you'll be able to type the desired name. After naming the equipment, save then advance. This method is repeated throughout the Configuration Wizard.



Begin the Configuration Wizard

In the Configuration Wizard, select “New” to create a new Configuration file for the OmniLogic. Once underway, keep advancing until you have completed the Wizard. At the end of the Wizard, you’ll have the opportunity to save your settings or exit without saving.

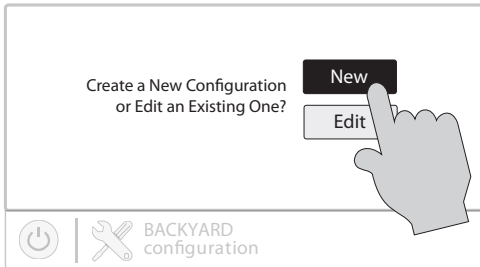

At the end of the Wizard, save your configuration by answering “Yes” to this screen.

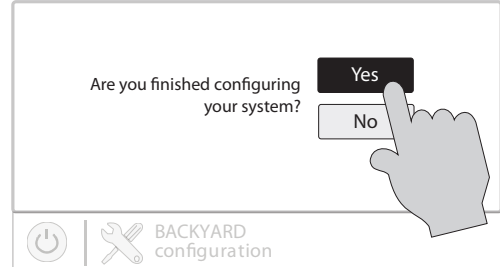

If additional pool or backyard equipment is added after initial configuration, or you’d like to make a change to an existing configuration setting, re-enter the Configuration Wizard and select “Edit”. The initial configuration settings will be retained and you’ll have an opportunity to make changes or additions. Be sure to save your configuration when exiting. See page 37 for a Quick Edit Guide.

Configuration Wizard Guide

As you progress through the Configuration Wizard, refer to the following information to help answer questions and make selections.

Select a Language - The OmniLogic will support multiple languages. Select the desired language then touch the Advance button to advance.

Time and Date - Set the current date and time using a 12hr clock (AM/PM) or 24hr clock (military time). Save by touching the Done button when finished. NOTE: When registering the OmniLogic and creating a web account, you’ll be prompted to enter a Time Zone. Be sure to enter the same time zone as the physical location of the OmniLogic, otherwise schedules and timers will be inaccurate.

Select Desired Units of Measure - If Standard is selected, temperatures will be displayed in Fahrenheit. If Metric is selected, temperatures will be displayed in Celsius.

MSP ID - The OmniLogic MSP ID number will be displayed. This unique number is used to identify your OmniLogic when setting up a web account. A web account is needed to access the OmniLogic over the web by mobile devices. **IMPORTANT:** write down the MSP ID number for future use. The MSP ID number will be needed when entering the configuration wizard after initial configuration as well as entering and exiting Simple Mode. Simple Mode is a customizable screen that can be set up for quick access to pool/spa functions and features.

How many Bodies of Water? The OmniLogic can support one or two bodies of water, typically a pool and spa. Select the number and advance. You’ll be brought to a screen where you can add, delete or edit a Body of Water. When initially configuring the OmniLogic, a “?” will appear in the Body of Water button. You will have to configure this body of water by selecting it and then touching the Advance button. When finished configuring bodies of water, you’ll be returned to this same screen. Touch the Done button and advance to the next section of configuration.

IMPORTANT: The following instructions are for Body of Water 1 configuration. When finished with the first Body of Water, you’ll follow the same instructions for the second Body of Water. When configuring the second Body of Water, you’ll have the option of using “Shared Equipment”. If Shared Equipment is enabled, the second Body of Water will use the filter pump as well as other equipment (heater, chlorinator, etc.) that has been assigned to the first Body of Water. Additionally, you will have the option for using “Shared Heaters”. If you have dual equipment with shared heaters, this can be configured from the second Body of Water’s configuration menu. See page 33 for more information regarding Shared Equipment in the second Body of Water configuration menu.

What is the Body of Water type? Select the type of Body of Water that you would like to configure. The choices are Pool and Spa.

Name of Body of Water - Selecting the box will allow you to edit the name. During initial configuration, the box will be blank. Select the box and then use the keyboard to enter the desired name of the body of water.

Size of Body of Water - Enter the Body of Water size in gallons. If you’re not certain the size of your pool, refer to the chart on the following page to help determine the pool capacity.

| | Gallons (pool size in feet) | Liters (pool size in meters) |
|--------------------|--|--|
| Rectangular | Length x Width x Average Depth x 7.5 | Length x Width x Average Depth x 1000 |
| Round | Diameter x Diameter x Average Depth x 5.9 | Diameter x Diameter x Average Depth x 785 |
| Oval | Length x Width x Average Depth x 6.7 | Length x Width x Average Depth x 893 |



HAYWARD®

How Many Filter Pumps? - This question is for THIS BODY OF WATER ONLY. For example: If you have 2 pumps; one for the pool Body of Water and one for the spa Body of Water, you would answer "1" to this question.

If "1" or more is selected:

Name Filter Pump - Touch the box and use the keyboard to name the filter pump.

What Type - Depending on your answer, the OmniLogic will use one relay (single speed pumps), two relays (two speed pumps) or the low speed communication bus (VSP pumps) for pump control. Select the type of pump and advance.

If one speed or two speed pump is selected:

Which Relay is it Wired to? If using a single speed or two speed pump, you'll be asked which relay(s) is wired to the pump. If a value is already shown in the box(es), advance to the next screen. If no value is shown, selecting the box will bring you to a table showing all detected relays. Select the proper relay(s) from the table and touch the Done button to proceed. The relay(s) should now be shown in the box(es) and you can advance to the next screen to continue the pump configuration.

Filter Pump Off for Valve Change? When Yes is selected, the pump will shut off for 35 seconds whenever the valve(s) change position.

Flow Monitoring Enabled? *Requires use of a Hayward flow switch.* This feature will help protect the filter pump from damage due to no flow. When Yes is selected, the OmniLogic will monitor the state of water flow when the filter pump is on. If no flow is detected for more than 20 minutes, the OmniLogic will shut down the pool pump and will indicate an error. The error will be cleared the next time the pump is turned on.

Would You Like to Enable Priming? Select whether you want the filter pump to prime when turned on. This will turn the pump on at high speed for 3 minutes to establish normal water flow every time the pump is activated after being off for at least 30 seconds. This option only appears if the filter pump is configured as a 2-Speed pump.

Freeze Protection Enabled? Freeze protection is used to protect the pool and plumbed equipment against freeze damage during cold temperatures. If freeze protection is enabled AND the air temperature falls below the freeze threshold, the OmniLogic will turn on the filter pump to circulate the water. If two Bodies of Water are configured, the valves will also alternate between the pool and spa every 30 minutes and the filter pump will turn off while the valves are turning. The chlorinator will not operate if freeze protection is the only reason the pump is running.

If Yes is selected:

Freeze Protection Temperature? Select the temperature to be used for freeze protection. Temperature is adjustable from 33°F-42°F (1°C-6°C). 38°F (3°C) is default. This threshold will be used for all outputs that have freeze protection enabled.

If VSP is selected:

Which Hayward Unique Address? If using a VSP, you'll be asked what is the Hayward Unique Address (HUA). If a value is already shown in the box, advance to the next screen. If no value is shown, selecting the box will bring you to a table showing all detected devices. Select the proper HUA from the table and touch the Done button. If unsure of the HUA, refer to the pump's manual for instructions on how to determine the pump's HUA. Once selected, the address should now be shown in the box and you can advance to the next screen to continue the VSP configuration.

Pump Capacity - Set the minimum and maximum RPM of the pump. Refer to your pump manual for more information.

Permitted User Setting - The OmniLogic will automatically calculate these values based on the minimum and maximum RPM that were previously entered. They can be changed as desired.

Speed Presets - Set the Low Pump Speed %, Medium Pump Speed %, and High Pump Speed %, presets. These presets will be used when setting schedules for your pump.

Filter Pump Off for Valve Change? When Yes is selected, the pump will shut off for 35 seconds whenever the valve(s) change position.

Flow Monitoring Enabled? *Requires use of a Hayward flow switch.* This feature will help protect the filter pump from damage due to no flow. When Yes is selected, the OmniLogic will monitor the state of water flow when the filter pump is on. If no flow is detected for more than 15 minutes, the OmniLogic will shut down the pool pump and will indicate an error. The error will be cleared the next time the pump is turned on.

Would You Like to Enable Priming? Select whether you want the filter pump to prime when turned on. This will turn the pump on at high speed for 3 minutes to establish normal water flow every time the pump is activated after being off for at least 30 seconds.

Freeze Protection Enabled? Freeze protection is used to protect the pool and plumbed equipment against freeze damage during cold temperatures. If freeze protection is enabled AND the air temperature falls below the freeze threshold, the OmniLogic will turn



on the filter pump to circulate the water. If two Bodies of Water are configured, the valves will also alternate between the pool and spa every 30 minutes and the filter pump will turn off while the valves are turning. The chlorinator will not operate if freeze protection is the only reason the pump is running.

If Yes is selected:

Freeze Protect Temperature? Select the temperature to be used for freeze protection. Temperature is adjustable from 33°F-42°F (1°C-6°C). 38°F (3°C) is default. This threshold will be used for all outputs that have freeze protection enabled.

Freeze Protect Speed? This is the speed of the pump while freeze protection is active. Select the desired pump speed %.

How many Heaters? This question is for THIS BODY OF WATER ONLY. For example: If you have 2 heaters, one for the pool Body of Water and one for the spa Body of Water, you would answer "1" to this question.

If "1" or more is selected:

Heater Cooldown Enabled? This feature ensures that the heater cools down before water circulation is stopped. When enabled, the Omni-Logic will continue to run the filter pump for 5 minutes after the heater turns off.

Heater Extend Enabled? If "Enabled", the filter extend logic keeps the filter pump running beyond the normal turn-off time until the pool (or spa) is heated up to the desired temperature setting. Heater extend will NOT cause the filter pump to turn on, it will only delay the turn off time when the heater is operating.

Maximum Settable Temperature? This is the maximum allowed setting for the heater regardless of its default range. There may be circumstances where you will want to limit the high temperature of your heater to a temperature that is lower than the factory high setting.

Select and Configure a Heater At this screen, you can add, delete and configure your heater(s). Select the desired heater, then touch the Advance button. When finished configuring heater(s), you'll be returned to this same screen. Touch the Done button and advance to the next section of configuration. Refer to the following information when configuring heater(s):

What Type? Heater choices are Solar, Heat Pump and Gas. Make your selection and advance.

If Gas Heater is selected:

Name Heater Select the box, then type the desired name for your heater. This name will be used when referring to this particular heater.

Which Relay is it Wired to? Selecting the box will bring you to a table showing all detected relays. Select the low voltage relay that is wired to the heater (refer to the Connection Table for this information), then advance. The relay should now be shown in the box. Advance to the next screen to continue gas heater configuration.

If more than one heater has been configured for this Body of Water:

Heater Priority Level? Because more than one heater is configured to heat this Body of Water, you can set the Priority for which heater you'd like to use first (selection "1"). If the priority heater can't meet the demand, the next heater will start (selection "2").

Heater Priority Duration? Set the amount of time that you will allow the priority heater ("1") to heat before allowing the next heater to start. If the priority heater meets the demand within this time frame, the next heater will not be used. Note that a time interval setting of "0" will eliminate priority and always run both heaters at the same time.

Minimum Operation Speed? For variable speed pumps, select the lowest pump speed that is allowed while heating. Set a speed that will ensure that there will be sufficient flow for the heater to operate properly.

If Heat Pump is selected:

Name Heater Select the box, then type the desired name for your heater. This name will be used when referring to this particular heater.

Which Relay is it Wired to? Selecting the box will bring you to a table showing all detected relays. Select the low voltage relay that is wired to the heater (refer to the Connection Table for this information), then advance. The relay should now be shown in the box. Advance to the next screen to continue heat pump configuration.

Minimum Allowed Air Temperature for Heater? If the air temperature falls below this setting, the heater will be prevented from running, regardless of conditions. This feature is especially useful for heat pumps which become less efficient as the outdoor ambient temperature falls.

If more than one heater has been configured for this Body of Water:

Heater Priority Level? Because more than one heater is configured to heat this Body of Water, you can set the Priority for which heater you'd like to use first (selection "1"). If the priority heater can't meet the demand, the next heater will start (selection "2").



HAYWARD®

Heater Priority Duration? Set the amount of time that you will allow the priority heater ("1") to heat before allowing the next heater to start. If the priority heater meets the demand within this time frame, the next heater will not be used.

Minimum Operation Speed? For variable speed pumps, select the lowest pump speed that is allowed while heating. Set a speed that will ensure that there will be sufficient flow for the heater to operate properly.

If Solar is selected:

Name Heater Select the box, then type the desired name for your heater. This name will be used when referring to this particular heater.

Does the Solar Heater Have a Pump? Select whether the solar heating system has a dedicated recirculation pump. If so, the OmniLogic will turn this pump on when the pool temperature is below the heater setting and there is solar heat available.

If Yes is selected:

Which Relay is it Wired to? Selecting the box will bring you to a table showing all detected relays. Select the high voltage relay that is wired to the heater (refer to the Connection Table in for this information), then advance. The relay should now be shown in the box. Advance to the next screen to continue solar heater configuration.

Does the Solar Heater Have a Valve? Select whether the solar heating system has a diverter valve to route pool/spa water through the solar collectors. If so, the OmniLogic will rotate this valve when the pool temperature is below the heater setting and there is solar heat available.

If Yes is selected:

Where is the valve wired? Selecting the box will bring you to a table showing all detected low voltage relays. Select the relay that is wired to the solar valve, then advance. The relay should now be shown in the box. Advance to the next screen to continue solar heater configuration.

Where is the Solar Temperature Sensor Located? Selecting the box will bring you to a table showing all detected sensors. Select the solar sensor (usually SENS3), then advance. The sensor should now be shown in the box. Advance to the next screen to continue solar heater configuration.

If more than one heater has been configured for this Body of Water:

Heater Priority Level? Because more than one heater is configured to heat this Body of Water, you can set the Priority for which heater you'd like to use first (selection "1"). If the priority heater can't meet the demand, the next heater will start (selection "2").

Heater Priority Duration? Set the amount of time that you will allow the priority heater ("1") to heat before allowing the next heater to start. If the priority heater meets the demand within this time frame, the next heater will not be used.

Minimum Operation Speed? Select the lowest pump speed that is allowed while solar heating. Set a speed that will ensure that there will be sufficient flow for the solar heating system to operate properly.

Do you have a Sense & Dispense Module? Select Yes if a Hayward HL-CHEM (sold separately) is connected to the OmniLogic.

If Yes is selected:

The next few screens will configure the OmniLogic to use Sense and Dispense. The OmniLogic automatically detects smart components like the HL-CHEM, and assigns a Hayward Unique Address. If multiple components are detected, the OmniLogic will show a table of devices and prompt you to select the proper device.

Which Hayward Unique Address? If a Hayward Unique Address (HUA) is already shown in the box, touch the Advance button. If no address is shown, selecting the box will bring you to a table showing all detected Sense and Dispense devices. Select the HL-CHEM from the table and touch the Done button to advance. The address should now be shown. Touch the Advance button to continue configuring the OmniLogic for use with the HL-CHEM.

Does ORP Control Chlorination? If you say Yes to this, the HL-CHEM will constantly measure ORP and will increase or decrease chlorine generation based on a predetermined setpoint that you will select. The system will monitor ORP and automatically generate the correct amount of chlorine to maintain a desired level. Alternatively, if you say No to this question, the HL-CHEM will monitor ORP, but the amount of chlorine generated will be based on a manual setting that you will select.

If Yes is selected:

ORP Setpoint - Set the desired ORP level which is measured in mV. 650mV is the default. The OmniLogic will continuously measure ORP and generate the proper amount of chlorine to maintain this setpoint.

ORP Timeout - Select a timeout interval. If the OmniLogic has been chlorinating for more than the selected ORP timeout without reaching the desired level, the chlorinator will turn off and display an alarm. The user must clear the alarm to resume chlorination.



Type of Cell? Select the type of Hayward TurboCell that is installed in your system.

Where is the Cell Located? If an entry is already shown in the box, touch the Advance button. If no entry is shown, selecting the box will bring you to a table showing the detected cell. Select the TurboCell and select Done.

If No is selected:

Do You Have a Salt Water Chlorine Generator? (requires Hayward Turbo Cell)

If Yes is selected:

Type of Cell? Select the type of Hayward TurboCell that is installed in your system.

Where is the Cell Located? If an entry is already shown in the box, touch the Advance button. If no entry is shown, selecting the box will bring you to a table showing the detected cell. Select the TurboCell select Done.

Percentage of Output - The OmniLogic can only generate chlorine while the filter pump is operating. Set the percentage of run time that you desire chlorine generation. Raise this value to generate more chlorine. Lower this value to generate less.

Is pH Reduction Enabled? Select Yes if you have a dispenser to lower pH connected to the OmniLogic.

If Yes is selected:

Are you Using Acid or CO₂? Select one.

How Many Acid/CO₂ Dispensers? Select the number of Acid/CO₂ dispensers in your system.

Which relay is it Wired to? Select the box to advance to the High Voltage Table. This table lists all of the high voltage relays that are installed in the OmniLogic. Select the relay that is wired to the pH dispense unit. Refer to the Connection Table for this information.

pH Setpoint - Selecting the box will allow you to change the setpoint (7.5 default). Touch the Advance button when finished.

pH Dispensing Timeout - Select a timeout interval. If the unit has been dispensing for more than the selected timeout without reaching the desired level, pH dispensing will turn off and an alarm will be displayed. Check the chemical supply and the feeder. If both are OK, the timeout may need to be increased. The user must clear the alarm to resume pH dispensing.

pH Extend Enabled - If enabled, the OmniLogic will continue to run the filter pump regardless of schedule until the pH level in the pool has reached the setpoint.

Do You Have a Salt Water Chlorine Generator? (requires Hayward Turbo Cell)

If Yes is selected:

Type of Cell? Select the type of Hayward TurboCell that is installed in your system.

Where is the Cell Located? If an entry is already shown in the box, touch the Advance button. If no entry is shown, selecting the box will bring you to a table showing the detected cell. Select the TurboCell and select Done.

Percentage of Output - The OmniLogic can only generate chlorine while the filter pump is operating. Set the percentage of run time that you desire chlorine generation. Raise this value to generate more chlorine. Lower this value to generate less.

How Many Cleaners? - This question is for THIS BODY OF WATER ONLY. For example: If you have 2 cleaners; one for the pool Body of Water and one for the spa Body of Water, you would answer "1" to this question.

If "1" or more is selected:

Select and Configure a Cleaner At this screen you can add, delete and configure your cleaner(s). Select the desired cleaner, then touch the Advance button. When finished configuring cleaner(s), you'll be returned to this same screen. Touch the Done button to advance to the next section of configuration. Refer to the following information when configuring cleaner(s):

Type of Cleaner? Touch the box and select the type of cleaner used. Choices are Pressure, Suction, Robotic and In-Floor.

Name of Cleaner - Touch the box and use the keyboard to name the cleaner.

Does Cleaner Have a Pump? Select whether the cleaner has a dedicated pump. If so, the OmniLogic will turn this pump on when the cleaner is scheduled to run.

If Yes is selected:

What Type? Select the type of pump used. The choices are Single Speed, Two Speed and VSP.

If single speed or two speed pump is selected:

Which Relay is it Wired to? If using a single speed or two speed pump, you'll be asked which relay(s) is wired to the



HAYWARD®

pump. If a value is already shown in the box(es), advance to the next screen. If no value is shown, selecting the box will bring you to a table showing all detected relays. Select the proper relay(s) from the table and touch the Done button. The relay should now be shown in the box(es) and you can advance to the next screen to continue the pump configuration.

Would You Like to Enable Priming? Select whether you want the pump to prime when turned on. This will turn the pump on at high speed for 3 minutes to establish normal water flow every time the pump is activated after being off for at least 30 seconds. This option only appears if the pump is configured as a 2-Speed pump.

If VSP is selected:

Which Hayward Unique Address? If using a VSP for your cleaner pump, you'll be asked what is the Hayward Unique Address (HUA). If a value is already shown in the box, advance to the next screen. If no value is shown, selecting the box will bring you to a table showing all detected devices. Select the proper HUA from the table and touch the Done button. The address should now be shown in the box and you can advance to the next screen to continue the VSP configuration.

Pump Capacity - Set the minimum and maximum RPM of the pump. Refer to your pump manual for more information.

Permitted User Setting - The OmniLogic will automatically calculate these values based on the minimum and maximum RPM that were previously entered. They can be changed as desired.

Speed Presets - Set the Low Pump Speed %, Medium Pump Speed %, and High Pump Speed %, presets. These presets will be used when setting schedules for your pump.

Would You Like to Enable Priming? Select whether you want the pump to prime when turned on. This will turn the pump on at high speed for 3 minutes to establish normal water flow every time the pump is activated after being off for at least 30 seconds.

Does Cleaner have a Valve? Select whether the cleaner requires a valve to change position when in use.

If Yes is selected:

How Many? Select how many valves are used for the cleaner.

Where is the Valve(s) Wired? Selecting the box will bring you to a table showing all detected low voltage relays. Select the relay(s) that is wired to the cleaner valve(s), then advance. The valve(s) should now be shown in the box(es). Advance to the next screen to continue cleaner configuration.

Would you like your valve(s) to cycle On and Off at a set interval? If you would like the cleaner valve(s) to cycle to a set interval while cleaning, select Yes. Set the interval on the next screen.

Freeze Protection Enabled? Freeze protection is used to protect the pool and plumbed equipment against freeze damage during cold temperatures. If freeze protection is enabled AND the air temperature falls below the freeze threshold (refer to pump configuration), the OmniLogic will turn on the cleaner pump to circulate the water.

How Many Water Features? - This question is for THIS BODY OF WATER ONLY. For example: If you have 2 water features; one for the pool Body of Water and one for the spa Body of Water, you would answer "1" to this question.

If "1" or more is selected:

Select and Configure a Water Feature At this screen you can add, delete and configure your water features. Select the desired water feature, then touch the Advance button. When finished configuring water features, you'll be returned to this same screen. Touch the Done button and advance to the next section of configuration. Refer to the following information when configuring water features:

Type of Water Feature? Touch the box and select the type of water feature used. Choices are Water Feature, Water Slide, Waterfall, and Fountain.

Name of Water Feature - Touch the box and use the keyboard to name the water feature.

Does Water feature Have a Pump? Select whether the water feature has a dedicated pump. If so, the OmniLogic will turn this pump on when the water feature is scheduled to run.

If Yes is selected:

What Type? Select the type of pump used. The choices are Single Speed, Two Speed and VSP.

If single speed or two speed pump is selected:

Which Relay is it Wired to? If using a single speed or two speed pump, you'll be asked which relay(s) is wired to the pump. If a value is already shown in the box(es), advance to the next screen. If no value is shown, selecting the box will bring you to a table showing all detected relays. Select the proper relay(s) from the table and touch the Done. The relay(s) should



now be shown in the box(es) and you can advance to the next screen to continue the pump configuration.

Would You Like to Enable Priming? Select whether you want the pump to prime when turned on. This will turn the pump on at high speed for 3 minutes to establish normal water flow every time the pump is activated after being off for at least 30 seconds. This option only appears if the pump is configured as a 2-Speed pump.

If VSP is selected:

Which Hayward Unique Address? If using a VSP for your water feature pump, you'll be asked what is the Hayward Unique Address (HUA). If a value is already shown in the box, advance to the next screen. If no value is shown, selecting the box will bring you to a table showing all detected devices. Select the proper HUA from the table and touch the Done button. If unsure of the HUA, refer to the pump's manual for instructions on how to determine the pump's HUA. Once selected, the address should now be shown in the box and you can advance to the next screen to continue the VSP configuration.

Pump Capacity - Set the minimum and maximum RPM of the pump. Refer to your pump manual for more information.

Permitted User Setting - The OmniLogic will automatically calculate these values based on the minimum and maximum RPM that were previously entered. They can be changed as desired.

Speed Presets - Set the Low Pump Speed %, Medium Pump Speed %, and High Pump Speed %, presets. These presets will be used when setting schedules for your pump.

Would You Like to Enable Priming? Select whether you want the pump to prime when turned on. This will turn the pump on at high speed for 3 minutes to establish normal water flow every time the pump is activated after being off for at least 30 seconds.

Water Feature Wired to a Relay? Select whether the water feature requires the use of a high voltage relay.

If Yes is selected:

Select Relay - Touching the box will bring you to a table showing all detected relays. Select the relay(s) that is connected to the water feature and touch the Done button. The relay should now be shown in the box and you can advance to the next screen to continue water feature configuration.

Does Water Feature have a Valve? Select whether the water feature requires a valve to change position when in use.

If Yes is selected:

How Many? Select how many valves are used for the water feature.

Where is the Valve(s) Wired? Selecting the box will bring you to a table showing all detected low voltage relays. Select the relay(s) that is wired to the water feature valve(s), then advance. The valve(s) should now be shown in the box. Advance to the next screen to continue water feature configuration.

Freeze Protection Enabled? Freeze protection is used to protect the pool and plumbed equipment against freeze damage during cold temperatures. If freeze protection is enabled AND the air temperature falls below the freeze threshold (refer to pump configuration), the OmniLogic will turn on the water feature pump to circulate the water.

Do You Want to Configure Any Non-Networked Lights? Select yes if you are using any type of Hayward ColorLogic pool or spa lights. Note that the OmniLogic can only support ColorLogic lights in Standalone mode using its high voltage relays. Controlling the lights requires power cycling so although more than one set of ColorLogic lights can be wired to the same relay, do not connect any other device to relays that are controlling ColorLogic lights.

If Yes is selected:

What Kind of Lights? Touch the box to select the type of ColorLogic lights that will be used. Selections are Universal ColorLogic (UCL), ColorLogic 4.0 (CL 4.0) and ColorLogic 2.5 (CL 2.5).

Name the Group of Lights - Touch the box and use the keyboard to name the ColorLogic lights.

How Many Relays are Lights Wired to? Select the number of relays used by the ColorLogic lights.

Which Relay is it Wired to? Touching the box(es) will bring you to a table showing all detected relays. Select the relay(s) that are connected to the ColorLogic lights and touch the Done button. The relay(s) should now be shown in the box(es) and you can advance to the next screen to continue the ColorLogic configuration.

Do you have any Universal ColorLogic lights that you'd like to set to UCL/CL 4.0/CL 2.5 operational mode? Select whether you have any Universal ColorLogic lights that need to be set to either UCL, CL 4.0 or CL 2.5 operational mode, depending on the kind of lights that you have configured.



HAYWARD®

How Many Accessories? Select the number of accessories that will be used for this Body of Water only. You'll have an opportunity to configure accessories for the spa and also the backyard at a later point.

If "1" or more is selected:

Select and Configure Accessories At this screen you can add, delete and configure your accessories. Select the desired accessory, then touch the Advance button. When finished configuring accessories, you'll be returned to this same screen. Touch the Done button and advance to the next section of configuration. Refer to the following information when configuring accessories:

Type of Accessory? Touch the box and select the type of accessory used. Choices are Laminars, Jets, Blower and Other.

Name of Accessory - Touch the box and use the keyboard to name the accessory.

Does Accessory Have a Pump? Select whether the accessory has a dedicated pump. If so, the OmniLogic will turn this pump on when the accessory is scheduled to run.

If Yes is selected:

What Type? Select the type of pump used. The choices are Single Speed, Two Speed and VSP.

If single speed or two speed pump is selected:

Which Relay is it Wired to? If using a single speed or two speed pump, you'll be asked which relay(s) is wired to the pump. If a value is already shown in the box(es), advance to the next screen. If no value is shown, selecting the box will bring you to a table showing all detected relays. Select the proper relay(s) from the table and touch the Done button. The relay(s) should now be shown in the box(es) and you can advance to the next screen to continue the pump configuration.

Would You Like to Enable Priming? Select whether you want the pump to prime when turned on. This will turn the pump on at high speed for 3 minutes to establish normal water flow every time the pump is activated after being off for at least 30 seconds. This option only appears if the pump is configured as a 2-Speed pump.

If VSP is selected:

Which Hayward Unique Address? If using a VSP for your accessory pump, you'll be asked what is the Hayward Unique Address (HUA). If a value is already shown in the box, advance to the next screen. If no value is shown, selecting the box will bring you to a table showing all detected devices. Select the proper HUA from the table and touch the Done button. The address should now be shown in the box and you can advance to the next screen to continue the VSP configuration.

Pump Capacity - Set the minimum and maximum RPM of the pump. Refer to your pump manual for more information.

Permitted User Setting - The OmniLogic will automatically calculate these values based on the minimum and maximum RPM that were previously entered. They can be changed as desired.

Speed Presets - Set the Low Pump Speed %, Medium Pump Speed %, and High Pump Speed %, presets. These presets will be used when setting schedules for your pump.

Would You Like to Enable Priming? Select whether you want the pump to prime when turned on. This will turn the pump on at high speed for 3 minutes to establish normal water flow every time the pump is activated after being off for at least 30 seconds.

Accessory Wired to Relay? Select whether the accessory requires the use of a high voltage relay.

If Yes is selected:

Select Relay - Touching the box will bring you to a table showing all detected relays. Select the relay that is connected to the accessory and touch the Done button. The relay should now be shown in the box and you can advance to the next screen to continue the accessory configuration.

Does Accessory have a Valve? Select whether the accessory requires a valve to change position when in use.

If Yes is selected:

How Many? Select how many valves are used for the accessory.

Where is the Valve(s) Wired? Selecting the box will bring you to a table showing all detected low voltage relays. Select the relay(s) that is wired to the accessory valve(s), then advance. The valve(s) should now be shown in the box. Advance to the next screen to continue accessory configuration.

Freeze Protection Enabled? Freeze protection is used to protect the pool and plumbed equipment against freeze damage during cold temperatures. If freeze protection is enabled AND the air temperature falls below the freeze threshold (refer to pump configuration), the OmniLogic will turn on the accessory pump to circulate the water.



NOTE: The following configuration settings are specific to the second Body of Water regarding Shared Equipment and Dual Equipment with shared heaters setup.

As you advance through the second Body of Water's configuration settings, note that most of the questions asked are the same as the first Body of Water with the exception of the following:

Does Body of Water 2 share its equipment with Body of Water 1?

If Yes is selected:

Your system will be "fully shared" which means your filter pump/heaters/chemistry will be shared between both Bodies of Water. You can now set your filter pump and heater settings for this body of water.

If No is selected:

You will begin dual equipment setup for you second Body of Water. This means that your filter pump and chemistry will not be shared between both Bodies of Water, but you will still have the option of configuring shared heaters and spillover. You can now configure a filter pump and heaters for this body of water.

Are any of Body of Water 2's heaters shared with Body of Water 1?

If Yes is selected:

Which body of water is heated in the event that both are running? Select the Body of Water that you would like to have heating priority if both Bodies of Water are running. This question only appears if you have a Pool/Pool or Spa/Spa setup. If you have a Pool/Spa setup, then the Spa Body of Water will automatically have heating priority.

Select Shared Heater Valves - Select Body of Water 1's return valve, Body of Water 2's return valve, and the Heater return valve in your system. The selections will also affect spillover operation.

Select the heaters you wish to share - Select the heaters that you configured in Body of Water 1 that you would like to be shared with Body of Water 2 and press advance.

Does this body of water have any additional heaters? Select whether you have any additional heaters in Body of Water 2 that you would like to configure that are not shared with Body of Water 1.

Do you have Spillover? Select yes to this question if you have Spillover in your system. If yes is selected, choose the valves that will operate Spillover from the following screen.

NOTE: The remaining configuration settings are not specific to a Body of Water.

Do You Have an Air Temperature Sensor? Select whether there is an air temperature sensor wired to the OmniLogic.

If Yes is selected:

Where is the Sensor Wired?

Touching the box will bring you to a table showing all detected sensors connections. Select the sensor connection used for the air sensor (typically SENS2) and touch the Done button. The sensor connection should now be shown in the box and you can advance to the next screen to continue configuration.

Do You Have a Water Temperature Sensor? Select whether there is a water temperature sensor wired to the OmniLogic.

If Yes is selected:

Where is the Sensor Wired?

Touching the box will bring you to a table showing all detected sensors connections. Select the sensor connection used for the water sensor (typically SENS1) and touch the Done button. The sensor connection should now be shown in the box and you can advance to the next screen to continue configuration.

Do You Have a Flow Switch? Select whether there is a flow switch wired to the OmniLogic.

If Yes is selected:

Where is the Sensor Wired?

Touching the box will bring you to a table showing all detected sensors connections. Select the sensor connection used for the flow switch (typically FLOW SWITCH 1) and touch the Done button. The sensor connection should now be shown in the box and you can advance to the next screen to continue configuration.

Select and Configure Sensors At this screen you can add, delete and configure your sensors. Select the desired sensor, then touch the Advance button. When finished configuring sensors, you'll be returned to this same screen. Touch the Done button and advance to the next section of configuration. Refer to the following information when configuring sensors:

Where is the Sensor Located? Touch the box and go to the table showing the Bodies of Water and the Backyard. Select the location where the sensor is installed.



HAYWARD®

What Type of Sensor? Select the type of sensor. Choices are Air, Water, Flow or Solar.

Name Sensor - Touch the box and use the keyboard to name the sensor.

Where is the Sensor Wired? Touching the box will bring you to a table showing all detected sensors connections. Select the sensor connection used for the sensor and touch the Done button. The sensor connection should now be shown in the box and you can advance to the next screen to continue configuration.

Do You Want to Configure Any Non-Networked Backyard Lights? Select yes if you are using any type of Hayward ColorLogic pool or spa lights in the backyard. Note that the OmniLogic can only support ColorLogic lights in Standalone mode using its high voltage relays. Controlling the lights requires power cycling so although more than one set of ColorLogic lights can be wired to the same relay, do not connect any other device to relays that are controlling ColorLogic lights.

If Yes is selected:

What Kind of Lights? Touch the box to select the type of ColorLogic lights that will be used. Selections are Universal ColorLogic (UCL), ColorLogic 4.0 (CL 4.0) and ColorLogic 2.5 (CL 2.5).

Name the Group of Lights - Touch the box and use the keyboard to name the ColorLogic lights.

How Many Relays are Lights Wired to? Select the number of relays used by the ColorLogic lights.

Which Relay is it Wired to? Touching the box(es) will bring you to a table showing all detected relays. Select the relay(s) that are connected to the ColorLogic lights and touch the Done button. The relay(s) should now be shown in the box(es) and you can advance to the next screen to continue the ColorLogic configuration.

Do you have any Universal ColorLogic lights that you'd like to set to UCL/CL 4.0/CL 2.5 operational mode? Select whether you have any Universal ColorLogic lights that need to be set to either UCL, CL 4.0 or CL 2.5 operational mode, depending on the kind of lights that you have configured.

How Many Accessories are in the Backyard? Select the number of accessories that will be used for the backyard.

If "1" or more is selected:

Select and Configure Accessories At this screen you can add, delete and configure your accessories. Select the desired accessory, then touch the Advance button. When finished configuring accessories, you'll be returned to this same screen. Touch the Done button and advance to the next section of configuration. Refer to the following information when configuring accessories:

Name of Accessory - Touch the box and use the keyboard to name the accessory.

Which Relay is it Wired to? Touching the box will bring you to a table showing all detected relays. Select the relay that is connected to the accessory and touch the Done button. The relay should now be shown in the box and you can advance to the next screen to continue the accessory configuration.

NOTE: Do not use the OmniLogic to control fire pits or any other fire related equipment.

Would You Like to Add an Interlock? An interlock will allow the OmniLogic to turn on or to turn off a piece of pool equipment (slave) based on the state of other pool equipment (master). An example of this is would be the desire to turn on walkway lighting (slave) every time the pool deck lights (master) are turned on. This equipment could have been wired together to accomplish the same function, but by interlocking the walkway lights to the deck lights, you'll maintain the ability to turn on the walkway lights independently.

An interlock can also control pool equipment based on the state of a temperature sensor or normally on/off switch. An example of this would be to turn on a cabana fan (slave) whenever the outside temperature sensor (master) reads above 90°F. Or, turning on a bug lamp (slave) when a photo sensor (master) detects that it is dusk.

If Yes is selected:

Select an Interlock Type - From this screen, select the type of interlock that you would like to configure. The choices are: Equipment to Equipment, Equipment to Flow Switch, Equipment to External Input, and Equipment to Temp. Sensor.

If Equipment to Equipment is selected:

Select Interlock Statement - Use the right and left arrows to choose the desired behavior of the interlock. The behavior for each interlock statement is described below.

If Equipment A is off, Equipment B can not be on - Equipment B will not turn on unless Equipment A is on. If both are running and Equipment A is turned off, Equipment B will turn off as well. Equipment B can be controlled independently as long as Equipment A is on.

If Equipment A is on, Equipment B can not be on - Equipment B will not turn on unless Equipment A is off. If Equipment B is running and Equipment A is turned on, Equipment B will turn off. Equipment B can be controlled independently as long as Equipment A is off.



HAYWARD®

If Equipment A is on, Equipment B is forced on - Equipment B is always off until Equipment A is turned on, at which point Equipment B will remain on until Equipment A is turned off. Equipment B cannot be controlled independently of Equipment A.

If Equipment A is on, Equipment B is forced off - Equipment B is always on until Equipment A is turned on, at which point Equipment B will remain off until Equipment A is turned off. Equipment B cannot be controlled independently of Equipment A.

Select Equipment - After selecting the desired interlock statement, use the buttons labeled “Equipment A” and “Equipment B” located below the interlock statement to choose the equipment that you would like to interlock. Pressing either button will bring you to another screen with all of the possible equipment that can be interlocked. Choose the desired equipment and then press save to lock in those values.

After saving the equipment, the interlock statement will change to include your selected equipment. Verify that the interlock statement correctly states the interlock that you would like to create and then press save to create the interlock.

If Equipment to Flow Switch is selected:

Select Interlock Statement - Use the right and left arrows to choose the desired behavior of the interlock. The behavior for each interlock statement is described below.

If the Flow Switch detects no flow, the Equipment can not be on - The Equipment can only turn on if the Flow Switch detects flow. Once the Flow Switch detects no flow, the Equipment is turned off and cannot be turned on again until the Flow Switch detects flow.

If the Flow Switch detects flow, the Equipment can not be on - The Equipment can only turn on if the Flow Switch detects no flow. Once the Flow Switch detects flow again, the Equipment is turned off and cannot be turned on again until the Flow Switch detects no flow.

If the Flow Switch detects flow, the Equipment is forced on - The Equipment is always on as long as the Flow Switch detects flow. Once the Flow Switch detects no flow, the Equipment will turn off. The Equipment cannot be controlled independently.

If the Flow Switch detects flow, the Equipment is forced off - The Equipment is always off as long as the Flow Switch detects flow. Once the Flow Switch detects no flow, the Equipment will turn on. The Equipment cannot be controlled independently.

Select Equipment - After selecting the desired interlock statement, use the buttons labeled “Flow Switch” and “Equipment” located below the interlock statement to choose the flow switch and equipment that you would like to interlock. Pressing either button will bring you to another screen with all of the possible equipment that can be interlocked. Choose the desired flow switch and equipment then press save to lock in those values.

After saving the equipment, the interlock statement will change to include your selected equipment. Verify that the interlock statement correctly states the interlock that you would like to create and then press save to create the interlock.

If Equipment to External Input is selected (requires that you have an external input configured):

Select Interlock Statement - Use the right and left arrows to choose the desired behavior of the interlock. The behavior for each interlock statement is described below.

If the External Input is closed, the Equipment can not be on - The Equipment can only turn on if the External Input is open. If the Equipment is running and then the External Input becomes closed, the Equipment will turn off. The Equipment can be controlled independently as long as the External Input is open.

If the External Input is open, the Equipment can not be on - The Equipment can only turn on if the External Input is closed. If the Equipment is running and then the External Input becomes open, the Equipment will turn off. The Equipment can be controlled independently as long as the External Input is closed.

If the External Input is closed, the Equipment is forced on - The Equipment is always off until the External Input becomes closed, at which time the Equipment will remain on until the External Input becomes open again. The Equipment cannot be controlled independently.

If the External Input is closed, the Equipment is forced off - The Equipment is always on until the External Input becomes closed, at which time the Equipment will remain off until the External Input becomes open again. The Equipment cannot be controlled independently.



HAYWARD®

Select Equipment - After selecting the desired interlock statement, use the buttons labeled “External Input” and “Equipment” located below the interlock statement to choose the external input and equipment that you would like to interlock. Pressing either button will bring you to another screen with all of the possible equipment that can be interlocked. Choose the desired external input and equipment then press save to lock in those values.

After saving the equipment, the interlock statement will change to include your selected equipment. Verify that the interlock statement correctly states the interlock that you would like to create and then press save to create the interlock.

NOTE: Freeze Protection will override External Interlocks for Filter Pumps but not for any other equipment.

If Equipment to Temp. Sensor is selected:

Select Interlock Statement - Use the right and left arrows to choose the desired behavior of the interlock. The behavior for each interlock statement is described below.

If the Temp. Sensor reads greater than Temperature degrees F, the Equipment can not be on - The Equipment can only be turned on if the Temp. Sensor reads less than the selected Temperature set-point. If the Equipment is running and then the Temp. Sensor reaches the selected Temperature set-point, the Equipment will turn off. The Equipment can be controlled independently as long as the Temp. Sensor reads less than the selected Temperature set-point.

If the Temp. Sensor reads less than Temperature degrees F, the Equipment can not be on - The Equipment can only be turned on if the Temp. Sensor reads greater than the selected Temperature set-point. If the Equipment is running and then the Temperature goes below the selected Temperature set-point, the Equipment will turn off. The Equipment can be controlled independently as long as the Temp. Sensor reads greater than the selected Temperature set-point.

If the Temp. Sensor reads greater than Temperature degrees F, the Equipment is forced on - The Equipment is always off until the Temp. Sensor reads greater than the selected Temperature set-point, at which time the Equipment will remain on until the Temperature falls back below the set-point. The Equipment cannot be controlled independently.

If the Temp. Sensor reads greater than Temperature degrees F, the Equipment is forced off - The Equipment is always on until the Temp. Sensor reads greater than the selected Temperature set-point, at which time the Equipment will remain off until the Temperature falls back below the set-point. The Equipment cannot be controlled independently.

Select Equipment - After selecting the desired interlock statement, use the buttons labeled “Temp. Sensor”, “Temperature” and “Equipment” located below the interlock statement to choose the temperature sensor, temperature and equipment that you would like to interlock. Pressing any of these buttons will bring you to another screen with all of the possible equipment that can be interlocked. Choose the desired temperature sensor, temperature and equipment then press save to lock in those values.

After saving the equipment, the interlock statement will change to include your selected equipment. Verify that the interlock statement correctly states the interlock that you would like to create and then press save to create the interlock.

Quick Edit Guide

If additional pool or backyard equipment is added after initial configuration, or you'd like to make a change to an existing configuration setting, re-enter the Configuration Wizard and select "Edit". Quick Edit allows you to go directly to the equipment that you'd like to add/remove/configure.

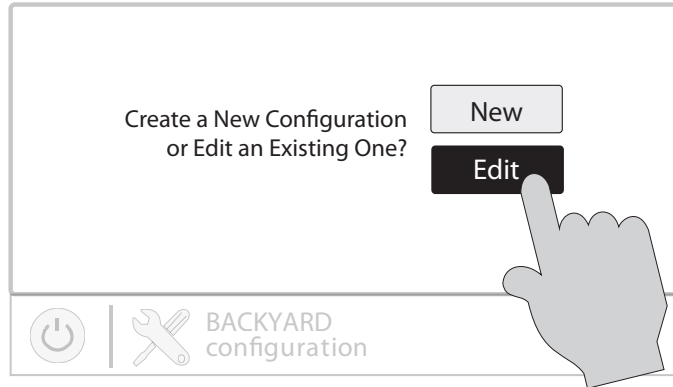



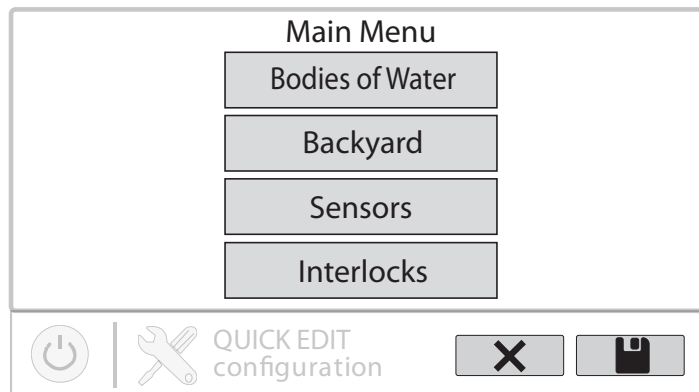

After selecting "Edit", the screen below will be shown. This screen will serve as the Main Menu screen for Quick Edit. When you have finished editing the configuration, you will return to this screen to save your changes.



Navigation

There are a number of additional buttons that appear in Quick Edit that either have functions unique to Quick Edit or do not appear anywhere else in the system. These buttons are as follows:

-  **Save** - Touch this button to save the configuration edit. This button only appears on the Quick Edit Home screen.
-  **Cancel** - Touch this button to cancel any changes made to the configuration and exit Quick Edit. This button only appears on the Quick Edit Home Screen.
-  **Home** - Touch this button to quickly jump back to the Quick Edit Main Menu Screen to save your changes. This button appears at the end of every configuration pathway.
-  **Back** - Touch this button to go back to the previous set of configurable items.

See page 24 for a full list of buttons that appear during configuration.

As you are using Quick Edit, you will notice that at the end of each pathway, a Home button and a back arrow will appear. If you are finished making changes, press the Home button and then press the Save button to save your configuration. If you would like to make more changes to the same device, press the back arrow. This will take you back to the last screen of configurable items for that device. If you would like to continue to make changes, but to a different device, press the Home button and then follow the pathway to the new device. The following pages will explain each configuration pathway.



HAYWARD®

Begin Using Quick Edit

From the Quick Main Menu Screen, select one of the following buttons and follow the directions on the next page to configure your equipment.

Bodies of Water
Backyard
Sensors
Interlocks/Add Interlock

If Bodies of Water is selected:

Select the body of water - Select the Body of Water that you would like to make changes to. Both bodies of water will have the same equipment options for Quick Edit.

Body of Water is selected:

Select the Equipment that you would like to configure - The options are as follows: Filter Pumps, Heaters, Chemistry, Cleaners, Water Features, Standalone Lights, Accessories, and Other Options. If the equipment is not already configured, then the buttons will appear as Add Heater, Add Chemistry, etc. When the button is pressed with the word "Add" before it, then you will be taken through the full configuration for that equipment as appears in the Configuration Guide portion of this manual. Otherwise:

If Filter Pumps is selected:

Select a Filter Pump - Once you select a filter pump, all of the options for that filter pump will appear on the next screen. These options are as follows:

Name - Rename the Filter Pump to whatever name you desire.

Type - Change the type of Filter Pump that is configured (Single Speed, 2-Speed, or VSP)

HUA - Match the HUA (Hayward Unique Address) to the configured Filter Pump. This option only appears if the Filter Pump is configured as a Variable Speed Pump.

Speed - Change the Minimum and Maximum Allowed Speeds of the Filter Pump as well as the Low, Medium and High speed settings. This option only appears if the Filter Pump is configured as a Variable Speed Pump.

Relay - Select the relay(s) that the Filter Pump is wired to. This option only appears if the Filter Pump is configured as a single speed or 2-Speed pump.

Off for Valve Change - Select whether you want the Filter Pump to shut off while valves are turning.

Flow Monitoring - Select whether you want flow to be monitored in this Body of Water.

Priming - Select whether you want the Filter Pump to prime. This option only appears if the Filter Pump is configured as a 2-Speed or Variable Speed Pump.

Freeze Protect - Select whether you want the Filter Pump to turn on for Freeze Protection. Also set the Freeze Protect air temperature threshold from this menu. Freeze protect operation can be overridden for a 60 minute period. (See Operation manual for more information).

If Heaters is selected:

Add a Heater - Pressing "Add a Heater" from this screen will take you through the full configuration for adding a new heater. These steps are described in the Configuration Guide portion of this manual.

General Heater Options - Pressing this button will take you to a screen with the following general options for heater operation:

Extend - Select whether you want Heater Extend enabled for this Body of Water.

Cooldown - Select whether you want Heater Cooldown enabled for this Body of Water.

Max Temperature - Select the Maximum Allowed Heater Setpoint Temperature for this Body of Water.

Select a Heater - Once you select a heater, all of the options for that heater will appear on the next screen. These options are as follows:

Name - Rename the heater to whatever name you desire.

Type - Select the type of heater that is configured (Solar, Heat Pump, Gas).



HAYWARD®

Relay - Select the relay that the heater is wired to. This option is only available if the heater is configured as a Heat Pump or a Gas heater.

Min Filter Speed - Select the minimum speed that the Filter Pump will run while the heater is active.

Min Air Temperature - Select the minimum air temperature that the heater will be allowed to run at. This option is only available if the heater is configured as a Heat Pump.

Priority Duration - Select the number of hours that this heater will run before the next priority heater turns on.

Pump - Configure the boost pump for the heater. This option is only available if the heater is configured as a Solar heater.

Valve - Configure the heating valve, if used. This option is only available if the heater is configured as a Solar heater.

Solar Sensor - Configure the solar sensor. This option is only available if the heater is configured as a Solar heater.

Delete a Heater - From this screen, if you wish to delete a heater that is currently configured, select the trash can on the right of the name of the heater that you wish to delete.

If Chemistry is selected:

pH - Once you select pH, all of the options for pH dispensing will appear on the next screen. These options are as follows:

Reduction ON - Select whether you want pH reduction to be enabled.

Chemical Type - Select the type of chemical that is being dispensed (acid or CO₂).

pH Dispensers - Configure the pH dispense unit.

pH Timeout - Choose the pH timeout time.

pH Extend - Select whether you want pH extend enabled for this Body of Water.

Chem Sense Module - Once you select Chem Sense Module, you will be able to select the HUA of your Chem Sense Module you are using from the next screen.

Chlorination - Once you select Chlorination, all of the options for chlorination will appear on the next screen. These options are as follows:

Cell Type - Select the type of Turbo Cell configured (T-Cell 3, 5, 9, 15).

Cell Relay - Select where the Turbo Cell is wired.

ORP/Timed - Select whether ORP controls chlorination or Timed Chlorination.

ORP Timeout - Choose the ORP timeout time. This option is only available if ORP controls chlorination.

Delete Chem Sense Module/Chlorination - From this screen, if you wish to delete any currently configured chemistry options, select the trash can on the right of the name of the item that you wish to delete.

NOTE: If either pH dispensing or chlorination are not configured, then this screen will give you the option to "Add CSM" or "Add Chlorination." If either of those options are selected, then you will be taken through the full configuration for that equipment as appears in the Configuration Guide portion of this manual.

If Cleaners is selected:

Add Cleaner - Pressing "Add Cleaner" from this screen will take you through the full configuration for adding a new cleaner. These steps are described in the Configuration Guide portion of this manual.

Select a Cleaner - Once you select a cleaner, all of the options for that cleaner will appear on the next screen. These options are as follows:

Name - Rename the cleaner to whatever name you desire.

Type - Select the type of cleaner that is configured (Pressure, Suction, Robotic, In Floor).

Pump - Configure the cleaner pump, if used.



HAYWARD®

Relay - Select the relay that the cleaner is wired to. This option only appears if the cleaner does not have an associated pump configured.

Valve - Configure the cleaner valve, if used.

Freeze Protect - Select whether you want the cleaner to turn on for Freeze Protection. Also set the Freeze Protect air temperature threshold from this menu.

Valve Cycle - Configure the valve cycling time period for the cleaner. This option is only available if the cleaner has an assigned valve.

Speed - Change the Minimum and Maximum Allowed Speeds of the cleaner as well as the Low, Medium and High speed settings. This option only appears if the cleaner pump is configured as a Variable Speed Pump.

Priming - Select whether you want the cleaner pump to prime. This option only appears if the cleaner pump is configured as a 2-Speed or Variable Speed Pump.

Delete a Cleaner - From this screen, if you wish to delete a cleaner that is currently configured, select the trash can on the right of the name of the cleaner that you wish to delete.

If Water Features is selected:

Add Water Feature - Pressing "Add Water Feature" from this screen will take you through the full configuration for adding a new water feature. These steps are described in the Configuration Guide portion of this manual.

Select a Water Feature - Once you select a water feature, all of the options for that water feature will appear on the next screen. These options are as follows:

Name - Rename the water feature to whatever name you desire.

Type - Change the type of water feature that is configured (Waterfall, Waterslide, etc.).

Pump - Configure the water feature pump, if used.

Relay - Select the relay that the water feature is wired to. This option appears only if the water feature does not have an associated pump configured.

Valve - Configure the water feature valve, if used.

Speed - Change the Minimum and Maximum Allowed Speeds of the water feature pump as well as the Low, Medium and High speed settings. This option only appears if the water feature pump is configured as a Variable Speed Pump.

Priming - Select whether you want the water feature pump to prime. This option is only available if the water feature pump is configured as a 2-Speed or Variable Speed Pump.

Freeze Protect - Select whether you want the water feature to turn on for Freeze Protection. Also set the Freeze Protect air temperature threshold from this menu.

Delete a Water Feature - From this screen, if you wish to delete a water feature that is currently configured, select the trash can on the right of the name of the water feature that you wish to delete.

If Standalone Lights is selected:

Add Standalone Light - Pressing "Add Standalone Light" from this screen will take you through the full configuration for adding new ColorLogic Standalone lights (UCL, CL 4.0 or CL 2.5). These steps are described in the Configuration Guide portion of this manual.

Select Group of Lights - Once you select a group of ColorLogic Standalone Lights, all of the options for those lights will appear on the next screen. These options are as follows:

Name - Rename the group of lights to whatever name is desired.

Type - Select the type of lights configured (UCL, CL4.0 or CL 2.5).

Relay - Select the relay(s) that the group of lights is wired to.

Set Mode - Set the mode of the lights configured (UCL, CL4.0 or CL 2.5).



Delete Group of Lights - From this screen, if you wish to delete a group of lights that is currently configured, select the trash can on the right of the name of the lights group that you wish to delete.

If Accessories is selected:

Add Accessory - Pressing "Add Accessory" from this screen will take you through the full configuration for adding a new accessory. These steps are described in the Configuration Guide portion of this manual.

Select an Accessory - Once you select an accessory, all of the options for that accessory will appear on the next screen. These options are as follows:

Name - Rename the accessory to whatever name you desire.

Type - Select the type of accessory configured (Laminar, Dimmer, etc.).

Pump - Configure the accessory pump, if used.

Valve - Configure the accessory valve, if used.

Speed - Change the Minimum and Maximum Allowed Speeds of the accessory pump as well as the Low, Medium and High Speed settings. This option only appears if the accessory pump is configured as a Variable Speed Pump.

Priming - Select whether you want the accessory pump to prime. This option is only available if the accessory pump is configured as a 2-Speed or Variable Speed Pump.

Freeze Protect - Select whether you want the accessory to turn on for Freeze Protection. Also set the Freeze Protect air temperature threshold from this menu.

Relay - Select the relay that the accessory is wired to. This option only appears if the accessory does not have an associated pump configured.

Delete an Accessory - From this screen, if you wish to delete an accessory that is currently configured, select the trash can on the right of the name of the accessory that you wish to delete.

If Other Options is selected:

Name - This is where you will be allowed to rename the Body of Water that you are currently configuring to whatever name you desire.

If Backyard is selected:

Add Standalone Light - Pressing "Add Standalone Light" from this screen will take you through the full configuration for adding new ColorLogic Standalone Lights (UCL, CL 4.0 or CL 2.5). These steps are described in the Configuration Guide portion of this manual.

Select Group of Lights - Once you select a group of ColorLogic Standalone Lights, all of the options for those lights will appear on the next screen. These options are as follows:

Name - Rename the group of lights to whatever name is desired.

Type - Select the type of lights configured (UCL, CL 4.0 or CL 2.5).

Relay - Select the relay(s) that the group of lights is wired to.

Set Mode - Set the mode of the lights configured (UCL, CL 4.0 or CL 2.5).

Delete Group of Lights - From this screen, if you wish to delete a group of lights that is currently configured, select the trash can on the right of the name of the lights group that you wish to delete.

If Accessories is selected:

Add Accessory - Pressing "Add Accessory" from this screen will take you through the full configuration for adding a new accessory to the Backyard. These steps are described in the Configuration Guide portion of this manual.

Select an Accessory - Once you select an accessory, all of the options for that Backyard accessory will appear on the next screen. These options are as follows:

Name - Rename the accessory to whatever name is desired.



Relay - Select the relay that the accessory is wired to.

Delete an Accessory - From this screen, if you wish to delete an accessory that is currently configured, select the trash can on the right of the name of the accessory that you wish to delete.

NOTE: The system does not allow you to configure a pump or a valve to accessory equipment in the Backyard.

If Sensors is selected:

Add Sensor - Pressing "Add Sensor" from this screen will take you through the full configuration for adding a new sensor. These steps are described in the Configuration Guide portion of this manual.

Select a Sensor - Once you select a sensor, all of the options for that sensor will appear on the next screen. These options are as follows:

Name - Rename the sensor to whatever name is desired.

Location - Select the location that the sensor is wired to.

Delete a sensor - From this screen, if you wish to delete a sensor that is currently configured, select the trash can on the right of the name of the sensor that you wish to delete.

If Interlocks is selected:

Add Interlock - Pressing "Add Interlock" from this screen will take you through the full configuration for adding a new interlock. These steps are described in the Configuration Guide portion of this manual.

Select an Interlock - Selecting an interlock from this screen will allow you to view that interlock's configuration. However, you cannot edit a pre-existing interlock. In order to change an interlock's configuration, you have to delete the obsolete interlock and create a new one.

Delete an Interlock - From this screen, if you wish to delete an interlock that is currently configured, select the trash can on the right of the name of the interlock that you wish to delete.

NOTE: If there are currently no interlocks configured on your system, then the button will appear as "Add Interlock" instead of "Interlocks". In this case, pressing "Add Interlock" will take you through the full configuration for adding a new interlock. These steps are described in the Configuration Guide portion of this manual. Once an interlock has been created, the button will say "Interlocks".



HAYWARD®

LIMITED WARRANTY (effective 03/01/12) Hayward warrants its OmniLogic, Pro Logic, OnCommand and E-Command pool automation products as well as its Aqua Rite, Aqua Rite Pro, Aqua Plus and SwimPure chlorination products to be free of defects in materials and workmanship, under normal use and service, for a period of three (3) years. Hayward also warrants its Aqua Trol chlorination products to be free of defects in materials and workmanship, under normal use and service for a period of one (1) year. These warranties are applicable from the initial date of purchase on private residential swimming pools in the US and Canada. Installations of product for use on commercial pools in the US and Canada is covered for a period of one (1) year for defects in materials and workmanship. Hayward warrants all accessories and replacement parts for the above-identified pool automation and chlorination products for a period of one (1) year. Accessories also include remotes, actuators, base stations, temperature sensors, flow switches and chemistry probes. Each of these warranties is not transferable and applies only to the original owner.

Hayward shall not be responsible for cartage, removal, repair or installation labor or any other such costs incurred in obtaining warranty replacements or repair.

Proof of purchase is required for warranty service. If written proof of purchase is not provided, the manufacturing date code will be the sole determinant of the date of installation of the product. To obtain warranty service or repair, please contact the place of purchase or the nearest Hayward authorized warranty service center. For more information on authorized service centers please contact the Hayward Technical Service Support Center (61 Whitecap Road, North Kingstown RI, 02852) or visit the Hayward web site at www.hayward.com.

WARRANTY EXCLUSIONS:

1. Material supplied or workmanship performed by others in process of installation.
2. Damage resulting from improper installation including installation on pools larger than the product rating.
3. Problems resulting from failure to install, operate or maintain the product(s) in accordance with the recommendations contained in the owners manual(s).
4. Problems resulting from failure to maintain pool water chemistry in accordance with the recommendations in the owners manual(s).
5. Problems resulting from tampering, accident, abuse, negligence, unauthorized repairs or alterations, fire, flood, lightning, freezing, external water, degradation of natural stone used in or immediately adjacent to a pool or spa, war or acts of God.
6. Use of a non-genuine Hayward replacement salt chlorination cell on any Hayward automation or chlorination product will void the warranty for that product.

The express limited warranty above constitutes the entire warranty of Hayward Pool Products with respect to its products and is in lieu of all other warranties expressed or implied, including warranties of merchantability or fitness for a particular purpose. In no event shall Hayward Pool products be responsible for any consequential, special or incidental damages of any nature. Some states do not allow a limitation on how long an implied warranty lasts, or the exclusion of incidental or consequential damages, so the above limitation may not apply to you. This warranty gives you specific legal rights, and you may also have other rights, which vary from state to state.



⚠ WARNING - Read and follow all instructions in this owner's manual and on the equipment. Failure to follow instructions can cause severe injury and/or death.

⚠ WARNING – Suction Entrapment Hazard.



Suction in suction outlets and/or suction outlet covers which are, damaged, broken, cracked, missing, or unsecured can cause severe injury and/or death due to the following entrapment hazards:



Hair Entrapment- Hair can become entangled in suction outlet cover.



Limb Entrapment- A limb inserted into an opening of a suction outlet sump or suction outlet cover that is damaged, broken, cracked, missing, or not securely attached can result in a mechanical bind or swelling of the limb.



Body Suction Entrapment- A negative pressure applied to a large portion of the body or limbs can result in an entrapment.

Evisceration/ Disembowelment - A negative pressure applied directly to the intestines through an unprotected suction outlet sump or suction outlet cover which is, damaged, broken, cracked, missing, or unsecured can result in evisceration/ disembowelment.



Mechanical Entrapment- There is potential for jewelry, swimsuit, hair decorations, finger, toe or knuckle to be caught in an opening of a suction outlet cover resulting in mechanical entrapment.

⚠ WARNING - To Reduce the risk of Entrapment Hazards:

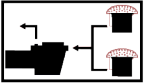

- o When outlets are small enough to be blocked by a person, a minimum of two functioning suction outlets per pump must be installed. Suction outlets in the same plane (i.e. floor or wall), must be installed a minimum of three feet (3') [1 meter] apart, as measured from near point to near point.
- o Dual suction fittings shall be placed in such locations and distances to avoid "dual blockage" by a user.
- o Dual suction fittings shall not be located on seating areas or on the backrest for such seating areas.
- o The maximum system flow rate shall not exceed the flow rating of as listed on Table 1.
- o Never use Pool or Spa if any suction outlet component is damaged, broken, cracked, missing, or not securely attached.
- o Replace damaged, broken, cracked, missing, or not securely attached suction outlet components immediately.
- o In addition two or more suction outlets per pump installed in accordance with latest ASME, APSP Standards and CPSC guidelines, follow all National, State, and Local codes applicable.
- o Installation of a vacuum release or vent system, which relieves entrapping suction, is recommended.

⚠ WARNING – Failure to remove pressure test plugs and/or plugs used in winterization of the pool/spa from the suction outlets can result in an increase potential for suction entrapment as described above.

⚠ WARNING – Failure to keep suction outlet components clear of debris, such as leaves, dirt, hair, paper and other material can result in an increase potential for suction entrapment as described above.

⚠ WARNING – Suction outlet components have a finite life, the cover/grate should be inspected frequently and replaced at least every ten years or if found to be damaged, broken, cracked, missing, or not securely attached.

⚠ CAUTION – Components such as the filtration system, pumps and heater must be positioned so as to prevent their being used as means of access to the pool by young children. To reduce risk of injury, do not permit children to use or climb on this product. Closely supervise children at all times. Components such as the filtration system, pumps, and heaters must be positioned to prevent children from using them as a means of access to the pool.



⚠ WARNING – Hazardous Pressure. Pool and spa water circulation systems operate under hazardous pressure during start up, normal operation, and after pump shut off. Stand clear of circulation system equipment during pump start up. Failure to follow safety and operation instructions could result in violent separation of the pump housing and cover, and/or filter housing and clamp due to pressure in the system, which could cause property damage, severe personal injury, or death. Before servicing pool and spa water circulation system, all system and pump controls must be in off position and filter manual air relief valve must be in open position. Before starting system pump, all system valves must be set in a position to allow system water to return back to the pool. Do not change filter control valve position while system pump is running. Before starting system pump, fully open filter manual air relief valve. Do not close filter manual air relief valve until a steady stream of water (not air or air and water) is discharged.



⚠ WARNING – Separation Hazard. Failure to follow safety and operation instructions could result in violent separation of pump and/or filter components. Strainer cover must be properly secured to pump housing with strainer cover lock ring. Before servicing pool and spa circulation system, filters manual air relief valve must be in open position. Do not operate pool and spa circulation system if a system component is not assembled properly, damaged, or missing. Do not operate pool and spa circulation system unless filter manual air relief valve body is in locked position in filter upper body. **Never operate or test the circulation system at more than 50 PSI.**



⚠ WARNING – Risk of Electric Shock. All electrical wiring **MUST** be in conformance with applicable local codes, regulations, and the National Electric Code (NEC). Hazardous voltage can shock, burn, and cause death or serious property damage. To reduce the risk of electric shock, do **NOT** use an extension cord to connect unit to electric supply. Provide a properly located electrical receptacle. Before working on any electrical equipment, turn off power supply to the equipment. To reduce the risk of electric shock replace damaged wiring immediately. Locate conduit to prevent abuse from lawn mowers, hedge trimmers and other equipment. Do **NOT** ground to a gas supply line.

⚠ WARNING – Risk of Electric Shock Failure to ground all electrical equipment can cause serious or fatal electrical shock hazard. Electrical ground all electrical equipment before connecting to electrical power supply.

⚠ WARNING – Risk of Electric Shock Failure to bond all electrical equipment to pool structure will increase risk for electrocution and could result in injury or death. To reduce the risk of electric shock, see installation instructions and consult a professional electrician on how to bond all electrical equipment. Also, contact a licensed electrician for information on local electrical codes for bonding requirements.

Notes to electrician: Use a solid copper conductor, size 8 or larger. Run a continuous wire from external bonding lug to reinforcing rod or mesh. Connect a No. 8 AWG (8.4 mm²) [No. 6 AWG (13.3 mm²) for Canada] solid copper bonding wire to the pressure wire connector provided on the electrical equipment and to all metal parts of swimming pool, spa, or hot tub, and metal piping (except gas piping), and conduit within 5 ft. (1.5 m) of inside walls of swimming pool, spa, or hot tub.

IMPORTANT - Reference NEC codes for all wiring standards including, but not limited to, grounding, bonding and other general wiring procedures.

⚠ WARNING – Risk of Electric Shock . The electrical equipment must be connected only to a supply circuit that is protected by a ground-fault circuit-interrupter (GFCI). Such a GFCI should be provided by the installer and should be tested on a routine basis. To test the GFCI, push the test button. The GFCI should interrupt power. Push reset button. Power should be restored. If the GFCI fails to operate in this manner, the GFCI is defective. If the GFCI interrupts power to the electrical equipment without the test button being pushed, a ground current is flowing, indicating the possibility of an electrical shock. Do not use this electrical equipment. Disconnect the electrical equipment and have the problem corrected by a qualified service representative before using.

⚠ CAUTION – HAYWARD® pumps are intended for use with permanently-installed pools and may be used with hot tubs and spas if so marked. Do not use with storable pools. A permanently-installed pool is constructed in or on the ground or in a building such that it cannot be readily disassembled for storage. A storable pool is constructed so that it is capable of being readily disassembled for storage and reassembled to its original integrity.

SAVE THESE INSTRUCTIONS





FOR FURTHER INFORMATION OR CONSUMER
TECHNICAL SUPPORT, VISIT OUR WEBSITE AT
www.hayward.com



Hayward is a registered trademark and OmniLogic is a
trademark of Hayward Industries, Inc. © 2016 Hayward Industries, Inc.

All other trademarks not owned by Hayward are the property of their respective owners.
Hayward is not in any way affiliated with or endorsed by those third parties.



092472



HAYWARD®

HLWLAN 802.11b/g/n Transceiver Kit

Wireless Communications for OmniLogic

Owner's Manual

Contents

| | |
|----------------------|---|
| Introduction..... | 1 |
| Installation..... | 2 |
| Configuration..... | 6 |
| Operation..... | 8 |
| Troubleshooting..... | 9 |

HLWLAN

Hayward Pool Products
620 Division Street, Elizabeth NJ 07207
www.hayward.com



HAYWARD®

FCC Statement

This device complies with part 15 of the FCC rules. Operation is subject to the following two conditions: (1) This device may not cause harmful interference, and (2) this device must accept any interference received, including interference that may cause undesired operation.

Changes or modifications not expressly approved by Hayward could void the user's authority to operate this equipment.

NOTE: This equipment has been tested and found to comply with the limits for a Class B digital device, pursuant to Part 15 of the FCC Rules. These limits are designed to provide reasonable protection against harmful interference in a residential installation. This equipment generates, uses and can radiate radio frequency energy and, if not installed and used in accordance with the instructions, may cause harmful interference to radio communications. However, there is no guarantee that interference will not occur in a particular installation. If this equipment does cause harmful interference to radio or television reception, which can be determined by turning the equipment off and on, the user is encouraged to try to correct the interference by one or more of the following measures:

- Reorient or relocate the receiving antenna.
- Increase the separation between the equipment and receiver.
- Connect the equipment into an outlet on a circuit different from that to which the receiver is connected.
- Consult the dealer or an experienced radio / TV technician for help.

Industry Canada Statement

This Class B digital apparatus complies with Canadian ICES-003.

Cet appareil numérique de la classe B est conforme à la norme NMB-003 du Canada.

The term "IC" before the certification / registration number only signifies that the Industry Canada technical specifications were met.

Radio Information

FCC ID: A8J-ENS200

IC: 10103A-ENS200



Introduction

The HLWLAN is a 802.11b/g/n Transceiver kit that can make a wireless connection from the OmniLogic up to 250ft to the home's router/access point preventing the need to run ethernet cable for web access. Connection to the web is necessary for remote access to the OmniLogic using web enabled devices.

Compatibility

Refer to this manual when using OmniLogic controls operating with MSP version R1.4.3 and greater. For earlier OmniLogic MSP revisions, refer to previous HLWLAN manual versions. To determine your OmniLogic's MSP version, select the "config" icon on the home screen and then select "system info" (see diagram on page 8).

Before You Begin

The HLWLAN kit contains the following:

- HLWLAN 802.11b/g/n Transceiver
- Power Injector
- OmniLogic power supply cable for Power over Ethernet (PoE) Injector
- 2 Ethernet Cables
- Miscellaneous mounting hardware

Installation of the HLWLAN requires that you have an existing wireless home network in range of the intended HLWLAN mounting location. The HLWLAN has a radio range of about 250ft. To connect the HLWLAN to your home network, you will need to know the home network's SSID, security type and password.

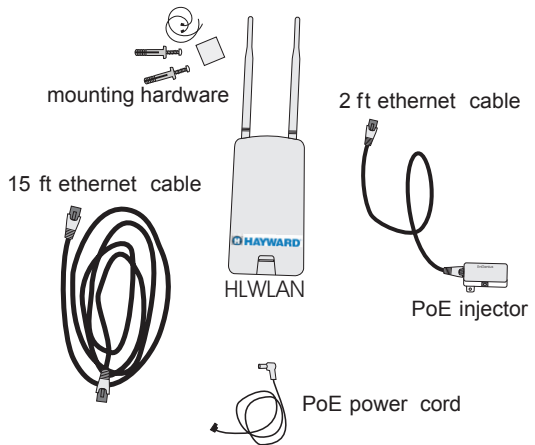

Survey the location near the OmniLogic to locate the best mounting location. The HLWLAN has a 15ft ethernet cable that connects to the OmniLogic. When determining the best mounting location for the HLWLAN, note that it can be mounted on the two provided screws or strapped to an object using the two included zip ties. To help determine if the mounting location is in range of the router/access point, test the connection of other devices (phone, tablet, laptop, etc.) at that same location.

If a reliable wireless connection can't be made in the intended location, consider moving the router/access point closer to the OmniLogic or using a longer outdoor rated ethernet cable to move the HLWLAN closer to the router/access point.



Router/Access Point Information

The HLWLAN cannot be configured without the following information. Before going any further with the installation, fill in the information below.

Router or Access Point's SSID *(wireless network name - case sensitive)* _____

To find the SSID:

- 1) Ask the homeowner. Each wireless router or access point has a default SSID which may be in use, or has been changed by the network administrator (homeowner).
- 2) If the homeowner doesn't know, have them login to the router/access point and read the information from the device. The SSID should be shown along with other router settings. The router's documentation or manual should show how to access administrative settings and find the SSID.
- 3) If a wireless device is already connected to the home network (phone, tablet, laptop, etc.), the device's connection properties may show the SSID.

Router or Access Point's Security Type _____

To find the Security Type:

- 1) Ask the homeowner. The network administrator (homeowner) would have set up the security type based on the desired security level and the type of devices that will be connecting to the wireless network.
- 2) If the homeowner doesn't know, have them login to the router/access point and read the security type from the device. This information should be shown along with other router settings. The router's documentation or manual will show how to access administrative settings and find the security type.
- 3) If a wireless device is already connected to the home network (phone, tablet, laptop, etc.), the device's connection properties may show the security type that is in use.

Wireless Network Password *(case sensitive)* _____

The wireless network password is not broadcast or typically saved in the router/access point's administrative settings. The network administrator (homeowner) would have set up a password when initially setting up the wireless security type. If no security was selected, the network is Open and there is no password.

Installation

DANGER of Death, Injury or Property Damage if procedure not followed. This accessory connects to the OmniLogic beneath the dead front panel. Dead front removal is required for this installation. Power to the OmniLogic panel **MUST** be shut off before the dead front is removed. This means a complete shutdown of power to the entire OmniLogic unit.



HAYWARD®

- 1) Depending on the mounting surface, use either the included screws/anchors or tie straps. A drilling template is included when using screws. Be sure that there are no major obstacles between the HLWLAN and the home's router/access point.

Loosely mount the HLWLAN so that you have visible access to the LED indicators on the bottom back of the unit. You will need to refer to these indicators before permanently fastening the HLWLAN.

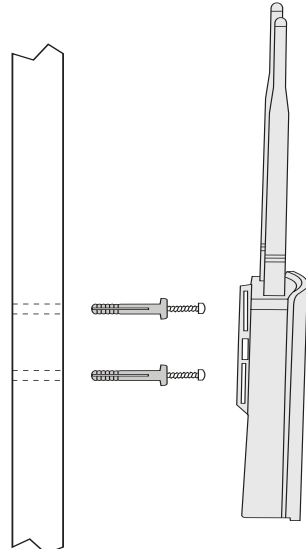

Attach PoE injector power cable to connector labeled "HLWLAN Power"

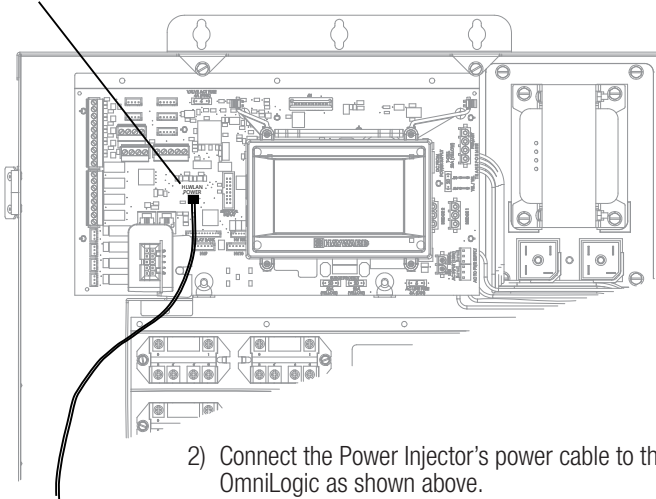

- 2) Connect the Power Injector's power cable to the OmniLogic as shown above.



HAYWARD®

Connect 2ft ethernet cable here

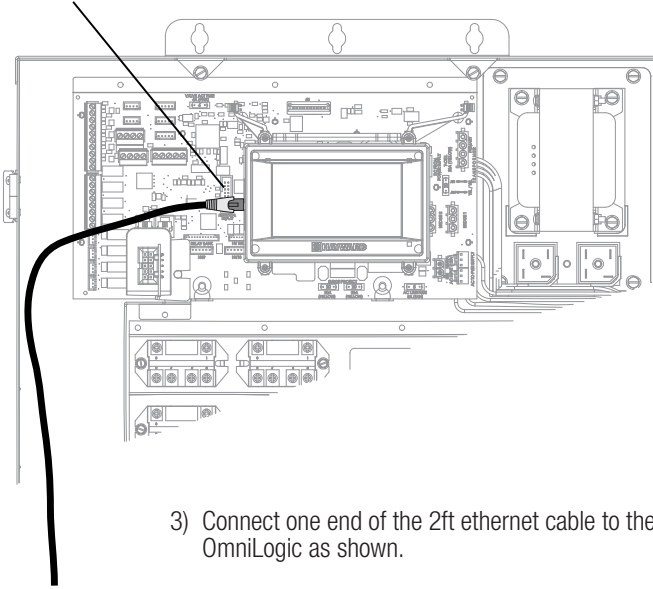

- 3) Connect one end of the 2ft ethernet cable to the OmniLogic as shown.

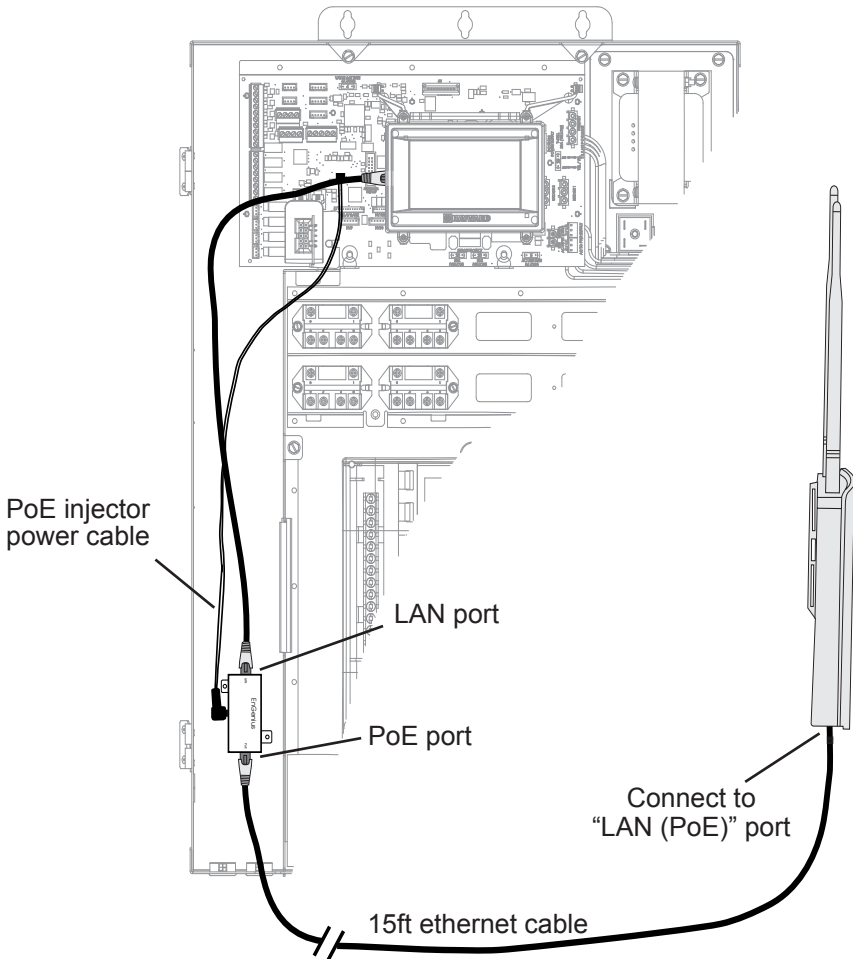

- 4) Position the Power Injector in a convenient location within the low voltage wiring compartment of the OmniLogic. You can fasten the Power Injector with double sided tape or Velcro, if desired. Connect the opposite end of the power supply cable. Connect the 2ft ethernet cable to the Power Injector's LAN port.

WARNING: The 2' ethernet cable comes plugged into the LAN port on the PoE Injector. DO NOT CHANGE THIS or you will damage the OmniLogic.

Connect one end of the 15ft outdoor ethernet cable to the Power Injector's PoE port and the other end to the port on the HLWLAN marked "LAN PoE". To access this port, remove the HLWLAN's bottom cover. Be sure to replace the cover when done.

After all connections are made, replace the OmniLogic dead front taking care that no wires are pinched.



Configuration

With the HLWLAN now connected, power up the OmniLogic. Wait about 3-4 minutes for the OmniLogic to fully start. Verify that the HLWLAN is being powered and is connected to the OmniLogic by looking at the PWR and LAN LED indicators on the backside near the ethernet connection. Both LEDs should be lit.

After verifying that the HLWLAN is powered, it must now be configured to connect to the wireless home network. From the OmniLogic's Local Terminal touchscreen, select the "Wifi Bridge" screen as shown below. Note that this cannot be performed from Remote Terminals.

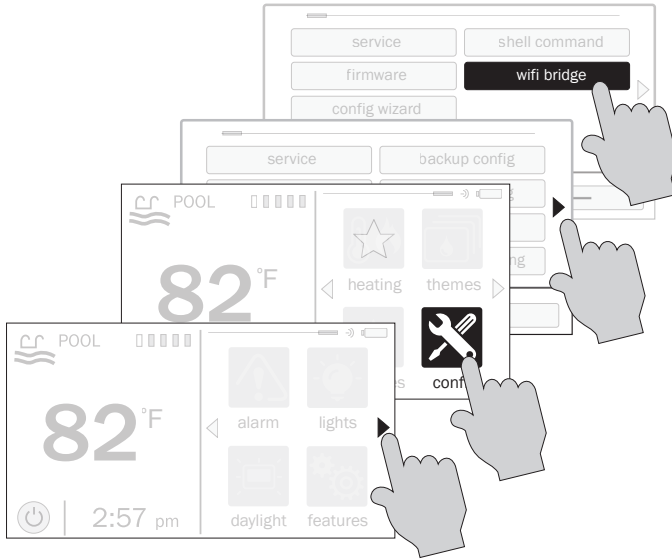



Wireless Bridge Configuration

The HLWLAN will now scan for available access points. Once it has finished, the SSID of all available access points will be displayed on the screen as shown below. Touching the desired SSID will begin the connection process. Depending on the security used by the router or access point, you may be prompted for a password.

Use to scroll through available access points

Use to refresh the list of available access points

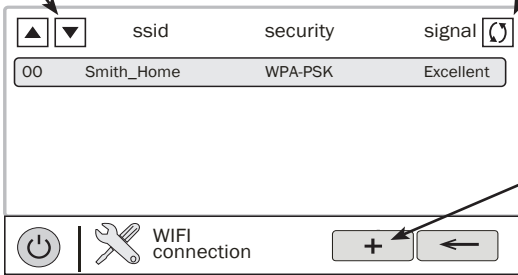

Use to manually configure an access point that does not appear in the list

If prompted for a password, the keypad will automatically appear. Enter the password and touch the check mark to move on. The HLWLAN will begin to automatically connect to the selected access point. Be patient -- this may take a few minutes to complete. Once complete, verify that you have connected to the home network by making sure that you have an entry next to "Local IP" in Protocol Properties, as shown below. Note that your Local IP address will likely be different than the one shown below. If *any* IP address is shown, the OmniLogic is connected to your home network. If "Not assigned" is shown, the OmniLogic is not connected to the home network and you should refer to Troubleshooting.

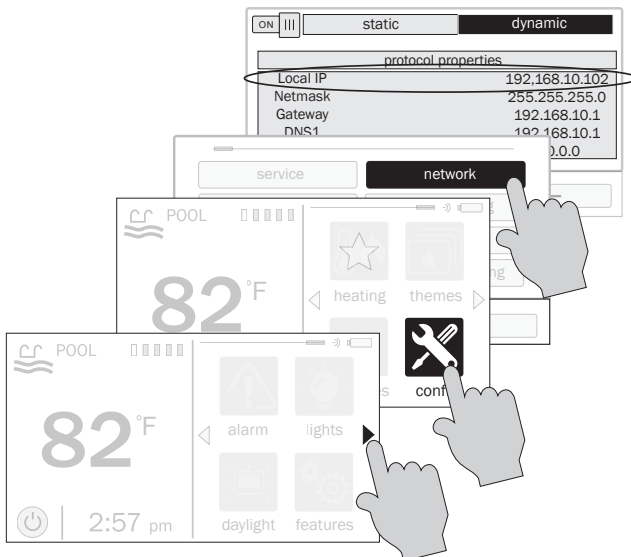



Signal Strength

When connected to the home network, the WLAN LED indicator will be lit and one of the Signal Strength LED indicators will be illuminated on the back of the HLWLAN. There are 3 LEDs indicating increasing signal strength from left to right. Be sure that at least the left most LED is on steady. If it is intermittently blinking, or not on at all, consider re-locating the HLWLAN or router/access point to acquire a better connection.

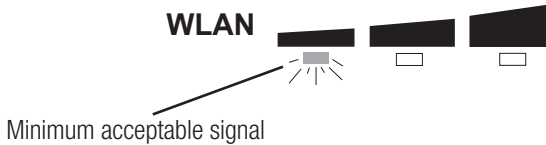

After verifying an acceptable signal, secure the HLWLAN to the mounting surface.

Operation

After successfully installing the HLWLAN, you will need to setup a Hayward OmniLogic user account in order to remotely access the OmniLogic through the web using a standard internet browser or mobile app. Follow instructions below.

- 1) Using an ordinary web browser, go to www.haywardomnilogic.com. If you don't already have an account, select "Register New User" and set up a new account.
- 2) Log in to your account.
- 3) Register your OmniLogic. While filling out the form to register your OmniLogic, you'll be asked for an MSP System ID. This number can be found directly from the OmniLogic. To find your unit's MSP ID, follow the procedure below:

MSP ID _____

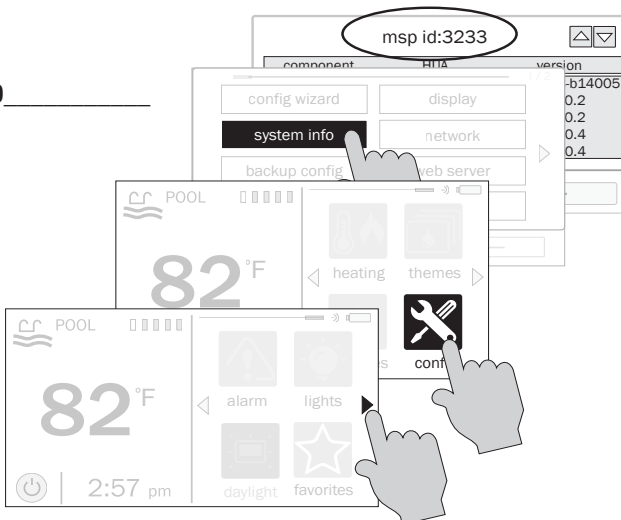



After the MSP is accepted, the OmniLogic will be linked to your account. You'll be able to access the OmniLogic at any time from your browser by logging into your account at haywardomnilogic.com. For mobile devices, an app must be downloaded from your device's app store. Go to www.hayward.com for more information on the availability and function of mobile apps.

Troubleshooting

1. The PWR and LAN LEDs are not lit.

This is an indication that the HLWLAN is not connected to the OmniLogic. Perform the following:

- Make sure that both ends of the ethernet cable are firmly connected; one side in the HLWLAN and the other in the PoE Injector (see Installation Steps 3 and 4).
- Make sure that the PoE Injector cable is firmly inserted in the HLBASE Main Board (Installation Step 2).
- Verify that the OmniLogic has power and that there is no break in the ethernet cable.

2. There is no "Local IP" address (page 7)

This is an indication that the HLWLAN is not connected to the home network.

- The HLWLAN may be mounted too far away from the home's router/access point or there may be too many obstructions between them. Using a Wifi capable phone, tablet or laptop, verify that other mobile devices can connect from that same location as the HLWLAN.
- If other devices can connect, the most likely cause is an error in the configuration settings. Reconnect the HLWLAN to the home's access point by following the procedure on page 7.
- If other devices cannot connect to the wireless network, consider relocating your router/access point or moving the HLWLAN closer using a longer outdoor rated ethernet cable.

3. Web enabled devices cannot connect to the OmniLogic

- Verify that you have an internet connection at your router/access point. Temporary outages with Internet Service Providers (ISPs) are not uncommon and the OmniLogic will be offline until service is restored.
- Have any changes been made to your home network? Any changes to your home network (router replacement, SSID name change, changes in security settings, IP reservation, etc.) may require you to repeat the configuration steps on page 7.
- Have you removed power from the OmniLogic or made changes that require it to reboot? If so, give the HLWLAN some additional time to reconnect to the home network.

For further information or technical support, visit our website at www.hayward.com.

For further information or consumer
technical support, visit our website at
www.hayward.com



HAYWARD[®]



Hayward is a registered trademark and OmniLogic is
a trademark of Hayward Industries, Inc. © 2013 Hayward Industries, Inc.

All other trademarks not owned by Hayward are the property of their respective owners.
Hayward is not in any way affiliated with or endorsed by those third parties.

USE ONLY HAYWARD GENUINE REPLACEMENT PARTS



HAYWARD®

Sense and Dispense™

ORP and pH Sensing Kit for OmniLogic

Owner's Manual



Contents

| | |
|-------------------|----|
| Description..... | 1 |
| Installation..... | 2 |
| Operation..... | 13 |
| Maintenance..... | 17 |
| Warranty..... | 18 |

HL-CHEM

Hayward Pool Products
620 Division Street, Elizabeth NJ 07207
www.hayward.com



HAYWARD®

FCC Statement

This device complies with part 15 of the FCC rules. Operation is subject to the following two conditions: (1) This device may not cause harmful interference, and (2) this device must accept any interference received, including interference that may cause undesired operation.

Changes or modifications not expressly approved by Hayward could void the user's authority to operate this equipment.

NOTE: This equipment has been tested and found to comply with the limits for a Class B digital device, pursuant to Part 15 of the FCC Rules. These limits are designed to provide reasonable protection against harmful interference in a residential installation. This equipment generates, uses and can radiate radio frequency energy and, if not installed and used in accordance with the instructions, may cause harmful interference to radio communications. However, there is no guarantee that interference will not occur in a particular installation. If this equipment does cause harmful interference to radio or television reception, which can be determined by turning the equipment off and on, the user is encouraged to try to correct the interference by one or more of the following measures:

- Reorient or relocate the receiving antenna.
- Increase the separation between the equipment and receiver.
- Connect the equipment into an outlet on a circuit different from that to which the receiver is connected.
- Consult the dealer or an experienced radio / TV technician for help.

Industry Canada Statement

This Class B digital apparatus complies with Canadian ICES-003.

Cet appareil numérique de la classe B est conforme à la norme NMB-003 du Canada.

The term "IC" before the certification / registration number only signifies that the Industry Canada technical specifications were met.

Description

The HL-CHEM is an ORP and pH sensing kit that is offered as an accessory for all OmniLogic® pool automation controls. With the HL-CHEM, the OmniLogic can provide a fully integrated chemistry solution for your pool. The HL-CHEM continuously tests the pool's sanitization and pH levels allowing the OmniLogic to automatically generate the correct amount of chlorine and dispense the proper amount of pH reducer. Together, they provide an automated system controlling both sanitization and pH balance.

The HL-CHEM comes with two pigtails (120 VAC and 240 VAC) for connection to a pH reducing device like a peristaltic pump or solenoid valve (not included) that requires a line cord receptacle. For easy integration, Hayward offers the AQL-CHEM2 (120 VAC) and AQL-CHEM2-240 (240 VAC) CO₂ dispense kit that plugs into the pigtail and will reduce the pool's pH level by injecting CO₂ into the pool water.



HAYWARD®

What's Included

The HL-CHEM comes with everything needed to allow the OmniLogic to sense ORP and pH levels. The following is a description of the included components:

Professional Grade ORP probe - Samples water from the pool filtration system and sends signals to the OmniLogic indicating the oxidation-reduction potential (redox) of the pool water. ORP is an actual measurement of sanitizer activity and bacteriological water quality rather than an expression of chemical residual levels. ORP is not fooled by the effects of pH, TDS (total dissolved solids) and other factors giving a more accurate measurement of the effectiveness of chlorine and water quality.

Professional Grade pH probe - Samples water from the pool filtration system and sends signals to the OmniLogic indicating the acidity of the water. When used with a Hayward AQL-CHEM2 or other pH dispensing device, the OmniLogic can keep the pool water's pH level balanced.

Probe Cell - The Probe Cell is used to house the probes and provide a location for water collection and testing. Two hoses are provided to connect the Probe Cell to the supply and return sides of the pool filtration system. The Probe Cell can be mounted directly to the OmniLogic or remote mounted in the vicinity of the control (restricted by the length of the probe wiring).

pH Dispense Pigtailed - The pH Dispense pigtailed provide a plug-in receptacle for the AQL-CHEM2, AQL-CHEM2-240 or other pH related dispensing device (peristaltic pumps, solenoid valves, etc.) that will be controlled by the OmniLogic.

Various Hardware - The HL-CHEM includes the necessary tubing, tubing connectors and mounting hardware to complete the installation.

Compatibility

The HL-CHEM is compatible with the OmniLogic pool control. An AQL-CL chemistry kit must be used with the OmniLogic if automatic chlorine generation is desired.

Installation

DANGER of Death, Injury or Property Damage if procedure not followed. This accessory connects to the OmniLogic panel beneath the dead front. Dead front removal is required for this installation. Power to the OmniLogic panel **MUST** be shut off before the dead front is removed. This means a complete shutdown of power to the entire OmniLogic panel

Overview

Installing the HL-CHEM requires the following steps:

- Mounting the Probe Cell
- Plumbing the Probe Cell
- Installing ORP and pH probes
- Wiring probes to Probe Cell communication box



HAYWARD®

- Wiring the Probe Cell to the OmniLogic
- Wiring the pH Dispense Pigtail to the OmniLogic
- Configuring the OmniLogic
- Validating Operation
- Establishing Maintenance Schedule

Materials Needed for Installation

- 7/16" drill bit
- ¼" NPT tap
- Two small adjustable wrenches if side mounting to OmniLogic
- 3/16" drill bit if side mounting to OmniLogic
- Deburring tool or file if side mounting
- Mounting hardware if surface mounting (not side mounting)
- Flex tubing cutter
- Water-tight strain relief for dispense pigtail
- Flathead screwdriver and mallet to remove knock-out and install strain relief
- 120 VAC Ground Fault Circuit Breaker (GFCB) for powering 120 VAC dispense pigtail or 240 VAC (GFCB) for powering 240 VAC dispense pigtail
- Extra wire, wire strippers, and wire nuts could be helpful in some installations
- Any items that would be required for wiring and installation per local code

Before carrying out any part of the installation, you **MUST** power down the OmniLogic panel. If the pool filter pump is not powered from the OmniLogic, it **MUST** be powered down separately. This will relieve pressure in the pool filtration system.

Mounting the Probe Cell

The Probe Cell can be mounted directly on the side of the OmniLogic or mounted up to 15' away (limited by length of Probe Cell cable). When mounting remotely, take into account the amount of cable needed to route through the OmniLogic.

The key to successful Probe Cell installation is in the plumbing. A pressure differential is required to allow clean, untreated water to pass through the cell and across the probes. Consider this when looking for an ideal mounting location.

Side Mounting: Side mounting the HL-CHEM will require drilling 3 mounting holes through the "dimples" found on the side of the OmniLogic enclosure. Refer to the diagram and steps below.

OmniLogic power must be shut off before the enclosure can be drilled.

- 1) Remove door and front panel.
- 2) Use a 3/16" dia. drill bit and drill through the three "dimples" on the side of the enclosure. Take care that any wires behind the enclosure wall are clear and will not be damaged by the drill bit.
- 3) After the holes are drilled, grind or file down any burrs and brush away any metal chips.
- 4) Route Probe Cell cable through access hole at bottom of Probe Cell mounting bracket.
- 5) Use the included stainless steel hardware to fasten the HL-CHEM to the OmniLogic as shown on the top of the following page.



HAYWARD®

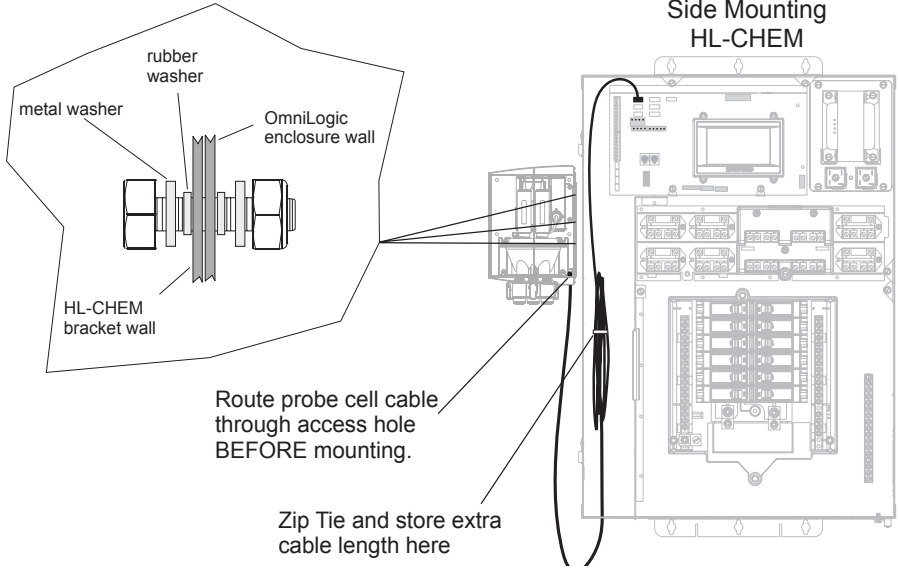

Surface mounting: The Probe Cell can be mounted up to 15' away from the OmniLogic (limited by length and routing of cable). Use the four mounting holes on the back of the bracket when surfacing mounting. Common wood screws can be used for most applications.

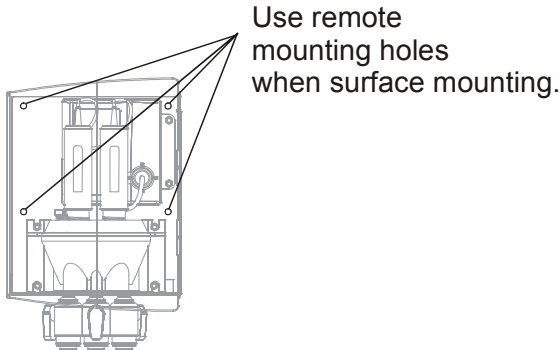

Plumbing the Probe Cell to the pool plumbing

The Probe Cell requires connection to the pool plumbing using the supplied flex tubing. Two ports on the Probe Cell, influent and effluent, are connected to the supply and return sides of the pool plumbing. Refer to diagram on the following page as well as the instructions.



HAYWARD®

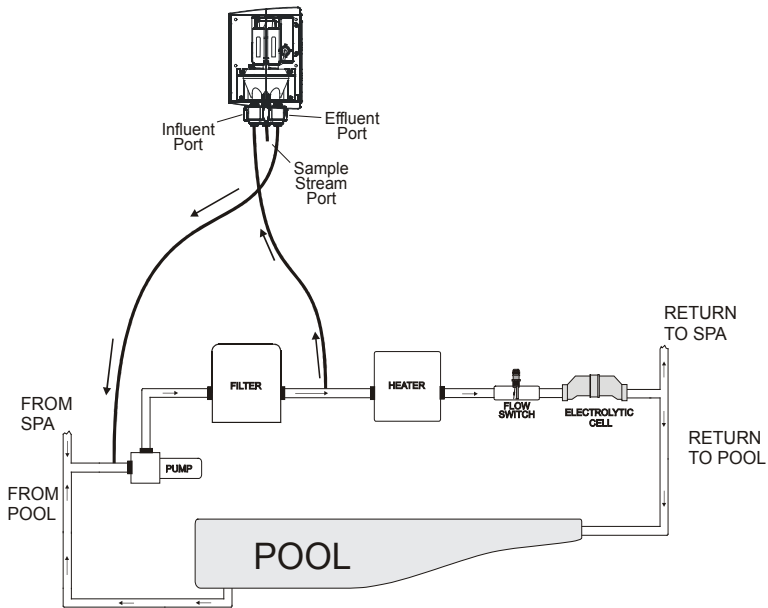

Drill and tap a $\frac{1}{4}$ " NPT hole using a $\frac{7}{16}$ " drill bit on the return side of the pool plumbing at a location just downstream of the filter, but upstream from the AQL-CL Electrolytic Cell. Use caution not to tap tapered threads too deeply. Using teflon plumber's tape, install a tubing connector into the hole. Run flex tubing from the tubing connector to the influent Probe Cell port. Push the flex tubing all the way into the pressure fitting to seat.

Drill and tap another $\frac{1}{4}$ " NPT hole on the supply side of the pool plumbing. Use caution not to tap tapered threads too deeply. Using teflon plumber's tape, install the remaining tubing connector and run flex tubing to the effluent Probe Cell port. Push the flex tubing all the way into the pressure fitting to seat.

Cut a 3" length of flex tubing and insert it into the sample stream port. This port can be used to draw water samples if needed.

If flex tubing needs to be replaced, use only $\frac{3}{8}$ " UV-resistant cross-linked polyethylene tubing (PEX).

Installing ORP and pH probes to the Probe Cell

The ORP and pH probes are shipped "wet" in plastic storage caps. It's very important that the probes remain wet at all times. If the probes are allowed to dry out, they will fail and the HL-CHEM will be ineffective. After installation, the Probe Cell will ensure that the probes are constantly exposed to pool water. During periods when the filter pump is off (even extended periods), there should be sufficient moisture remaining in the Probe Cell to ensure that the probes are protected.

Remove the ORP and pH probes from their plastic storage caps and save the caps for future use.

To ensure that the probes continue to remain wet, fill the Probe Cell with pool water before installing the probes. Apply a length of plumber's tape to the probe threads. Hand-tighten the probes only. At startup, check for leaks. If probe leaks, do not tighten more—instead remove and re-apply new Teflon tape.

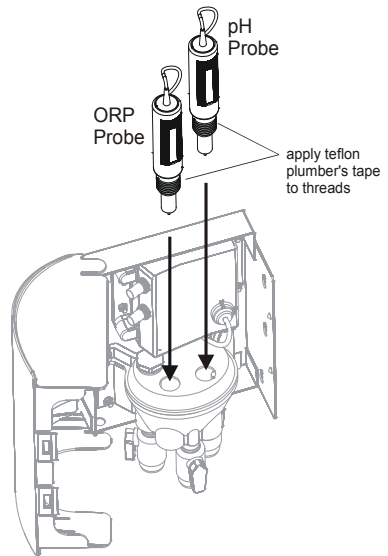

Wiring the probes to the Probe Cell

Both probes must be wired to the communication box within the Probe Cell. The probe cables use typical BNC connectors that attach to the designated connectors on the communication box. Refer to the label on the communication box for the appropriate connections. Push the connectors in and turn clockwise until locked. After connecting, route the wires in a manner where they will not interfere with the door of the Probe Cell. Save BNC connector protective covers for future use.

Wiring the Probe Cell to the OmniLogic

With power off to the OmniLogic, remove the dead front to expose the main board. Route the Probe Cell cable through an available knockout, along the low voltage channel and make the proper connection to the low speed RS-485 bus (4 pin connector) as shown below. When side mounting the Probe Cell, route the cable through the access hole at the bottom of the mounting bracket BEFORE screwing the bracket in place.

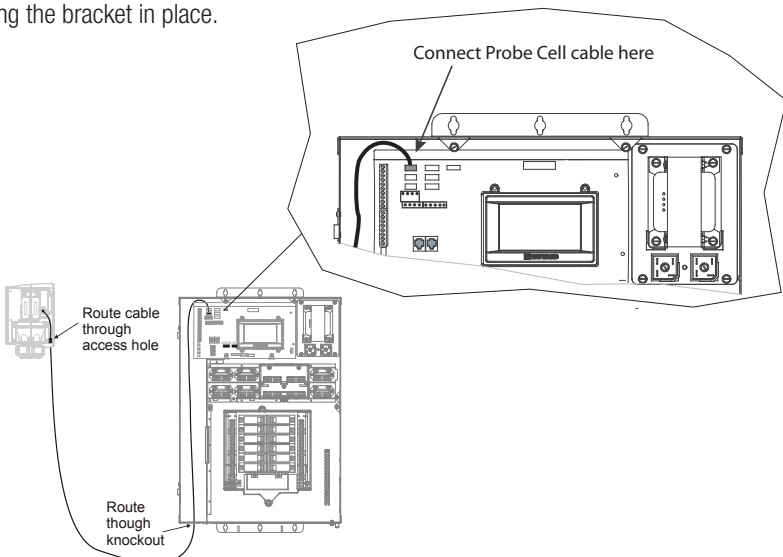



Wiring the Pigtail or pH Dispensing Device

Two pigtails (120 VAC and 240 VAC) are included with the HL-CHEM sensing kit to be used with pH dispensing devices (peristaltic pumps, solenoid valves, etc.) that require a plug-in receptacle, including the Hayward AQL-CHEM2 and AQL-CHEM2-240. If your pH dispensing device will be direct wired (hard wired), the pigtail is not necessary.

WARNING: Follow local codes for pigtail installation. Installation may require retrofitting a weather-tight outlet and plug to the pigtail and dispense hardware (such as Cooper WaterTight or similar connectors) or weather proof junction box.

NOTE: The OmniLogic can use either a 120 VAC or 240 VAC pH dispensing device. Wire the pigtail or device directly to any of the OmniLogic relays. Provide the proper input voltage to the line side of the relay. For 120 VAC, refer to the diagram below. For 240 VAC, refer to the diagram on page 8.

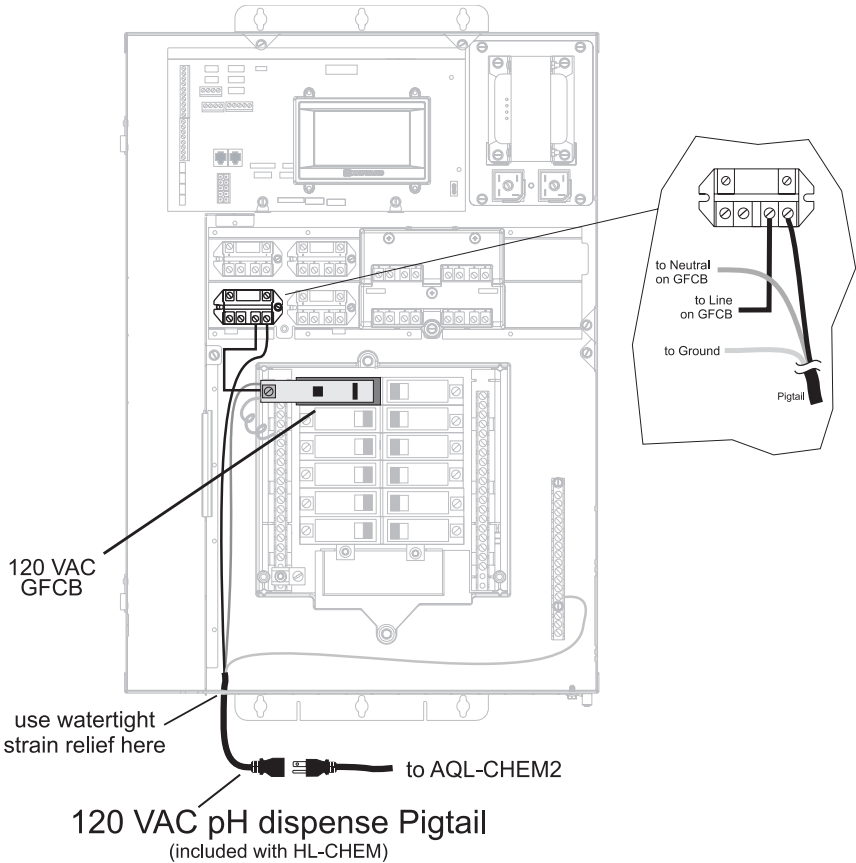



HAYWARD®

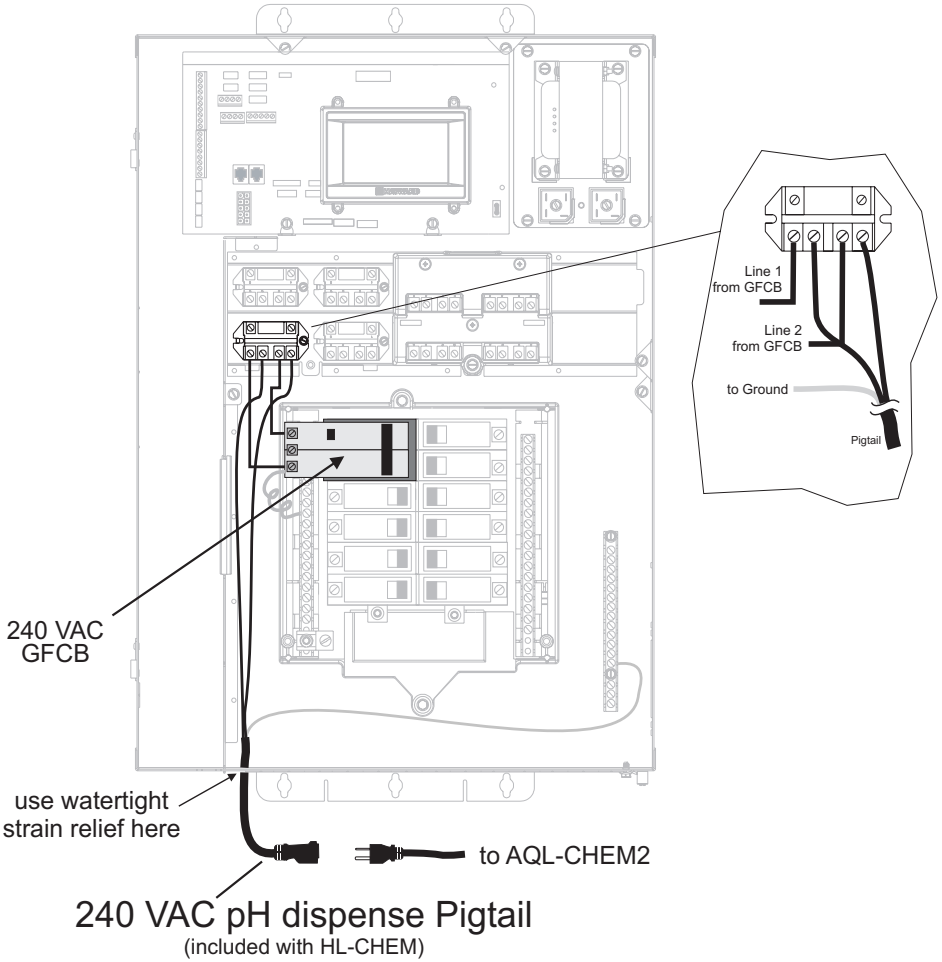



Configuring the OmniLogic

After the HL-CHEM is mounted, plumbed and wired, the OmniLogic must be configured to use the HL-CHEM.

Replace the dead front and restore power to the OmniLogic. At the HOME screen, go to CONFIGURATION in the BACKYARD SCREENS. Enter the CONFIGURATION WIZARD and advance through the menus until you see the screen below.

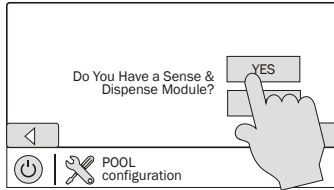

After selecting "Yes", the HL-CHEM will be automatically discovered and you'll be prompted to select a unique address.

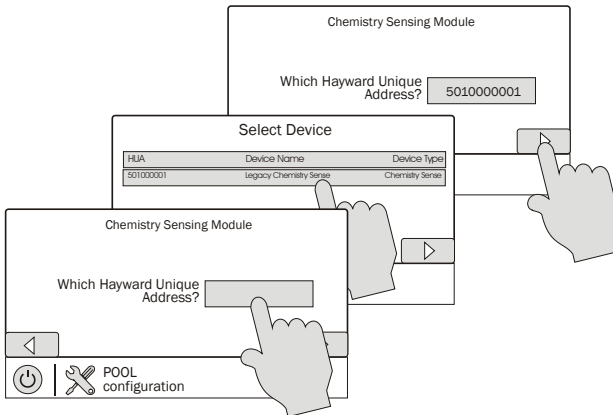

Pressing the box will bring you to a table which shows a list of connected devices. Selecting the HL-CHEM from this table will automatically configure the OmniLogic to use the proper address.

The HL-CHEM is now ready to be configured. You'll be presented with a series of screens that will require you to input desired operating parameters and settings. Refer to the related information on the following pages as you progress through the screens.

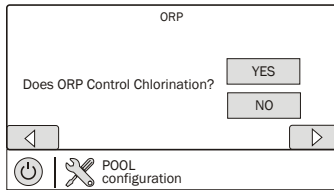

ORP Control

A Hayward AQL-CL Chlorination Kit is needed if chlorine generation is desired.

If "Yes" is selected (AQL-CL Chlorination Kit must be used): You'll automatically be asked to configure ORP settings as shown below. The OmniLogic refers to the ORP level in the pool and automatically adjusts chlorine output to maintain the desired level.

If "No" is selected, and a AQL-CL Chlorination Kit is used: After answering "No", you'll be asked if a Salt Water Chlorine Generator will be used. If you answer "Yes" to this, you'll be prompted to enter a run time %. The OmniLogic will generate chlorine for this % of time during the filter cycle. Chlorine output is based on this manual setting only. ORP level is not used to control the chlorinator output.

If "No" is selected, and a AQL-CL Chlorination Kit is NOT used: After answering "No", you'll be asked if a Salt Water Chlorine Generator will be used. When you answer "No", you'll advance directly to pH configuration.

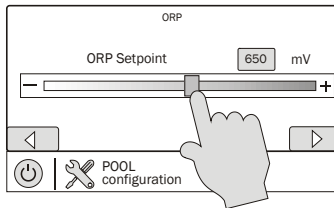

ORP Setpoint

Refer to "Controlling ORP with the OmniLogic" on page 15 for tips on determining the ORP setpoint (650mV default). The HL-CHEM will measure the pool's ORP and generate more or less chlorine to maintain the setpoint setting. Note that the OmniLogic will attempt to maintain this level but typically the pool's ORP level will vary above this value during normal operation. The adjustable range is from 400mV to 900mV in 5mV increments.

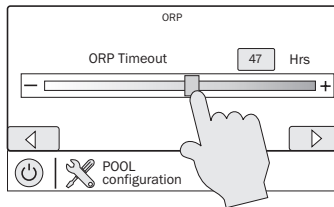

ORP Timeout

To protect the pool, the OmniLogic control will automatically shut down ORP control and display an alarm if the HL-CHEM runs continuously for more than the selected timeout value. This prevents a situation where the OmniLogic is constantly feeding chlorine because of a probe error or external problem with the pool. It allows the pool owner to evaluate the pool chemistry before continuing with ORP control. Select the desired timeout value.

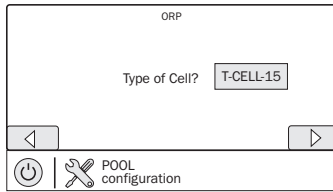

Select Cell

The OmniLogic can use the following Hayward TurboCells:

- T-CELL-15 - select when using T-CELL-15 (inc. with AQL-CL), GLX-CELL-15-W
- T-CELL-9 - select when using T-CELL-9, GLX-CELL-9-W
- T-CELL-3 - select when using T-CELL-3, GLX-CELL-3-W
- T-CELL-5 - select when using GLX-CELL-5, GLX-CELL-5-W

NOTE: Use of a non-genuine Hayward replacement salt chlorination cell on any Hayward automation or chlorination product will void the warranty for that product and could potentially damage the unit.

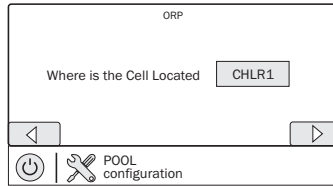

TurboCell Location

Like the HL-CHEM, the TurboCell will automatically be sensed and you will be prompted to select the proper location. Follow the same procedure as shown on page 9.

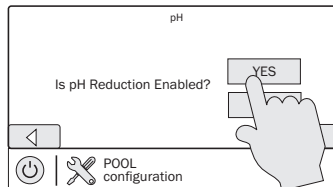

pH Control

If automatic pH reduction is desired, a dispensing device must be connected to one of the relays in the OmniLogic. If so, select "Yes" and configure pH reduction with the following screens.

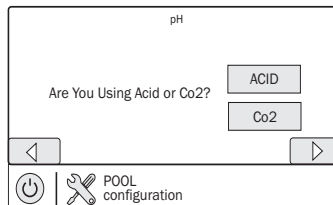

Acid or CO₂

Select the type of pH reduction that will be used.

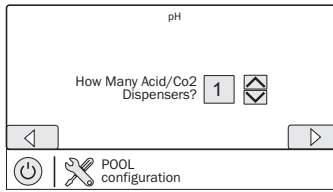

Number of Dispensers

Select the number of dispensers that are wired to the OmniLogic.

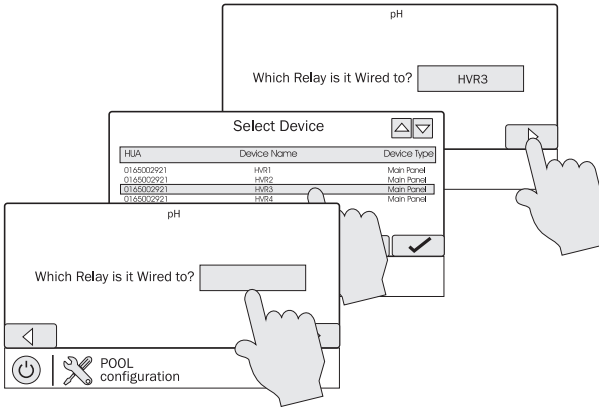

Relay Device Name

Configure the OmniLogic to use the acid or CO₂ dispenser by selecting the relay that is wired to the dispenser.

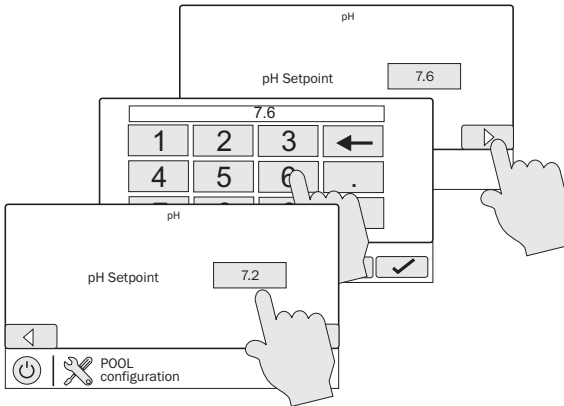

pH Setpoint

Enter the desired pH level. The OmniLogic will dispense CO₂ or acid when necessary to maintain this level. The adjustable range is from 7 to 8 in 0.1 increments.



HAYWARD®

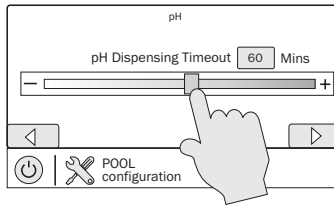

pH Timeout

To protect the pool, the OmniLogic control will automatically shut down pH control and display an alarm if the HL-CHEM runs continuously for more than the selected timeout value. This prevents a situation where the OmniLogic is constantly feeding acid or CO₂ because of a probe error or external problem with the pool. It allows the pool owner to evaluate the pool chemistry before continuing with pH control. The selectable range is 1-120 minutes.

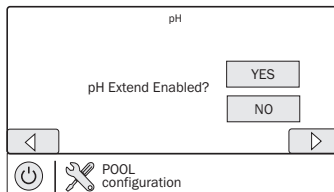

pH Extend

When pH Extend is enabled, the OmniLogic control will keep the pool filter pump on regardless of its timer settings until the pH level is within its programmed parameters. The pump will continue to run and acid or CO₂ will continue to dispense until the programmed levels are reached. When the pH level reaches the setpoint, the pump will be allowed to go back to automatic control.

Operation

Before operating the HL-CHEM, test and adjust the pool water chemistry to the recommended levels shown in the OmniLogic Owner's Manuals. This is an important step and is crucial to the successful operation of the HL-CHEM. If using salt chlorination, adjust salt to recommended levels.

Alarms

After exiting the CONFIGURATION WIZARD, alarms for both ORP and pH will be enabled. To view alarms, click on the ALARM icon found in the BACKYARD SCREENS. Refer to the OmniLogic manual for more information about alarms.

ORP Alarm

The OmniLogic will automatically set a high and low alarm for the ORP level. The high alarm point is 850mV and the low alarm point is 350mV. If the ORP level meets or exceeds these points, an alarm message will display locally and on all remote controls. Also, if the ORP level is too high, chlorine generation will shut down.



pH Alarm

The OmniLogic will automatically set a high and low alarm for the pH level. The high alarm point is 8.1 and the low alarm point is 6.9.

Settings

Although initial settings were entered during configuration, changes may be desired as pool conditions change. To quickly display and change settings, select the desired Body of Water at the HOME SCREEN then go to the SETTINGS SCREEN. Select the following:

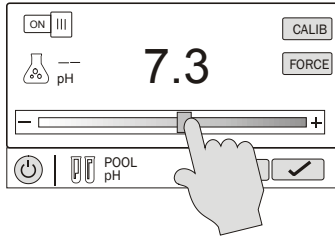
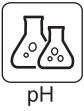

pH Setting Adjust setpoint from 7.0 to 8.0.

On/Off Enable and disable pH dispensing.

Force pH reducer is added for 15 minutes regardless of pH level and then automatically goes to Auto Sensing mode. This mode is helpful when setting up and testing the AQL-CHEM2(-240) or other automatic dispenser.

Calib pH Calibration should take place at initial setup and periodically when the pH read-out doesn't match tested values.

To calibrate the pH probe, test the pH of the pool water with a dependable quality test kit after the pool pump has been running for a period of time. Hayward suggests that you take more than one test and average the results before using the value to calibrate. Compare this result to the current pH reading and enter the offset amount. If the tested value is lower than the current reading, the offset will be negative. If greater, the offset will be positive. Refer to the example below.

Current pH reading: 7.5.
Average of tested readings: 7.3.
Offset: $7.3 - 7.5 = -.2$

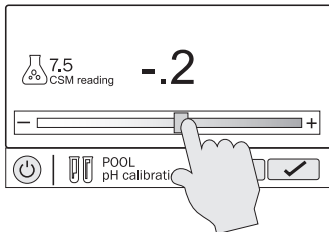



HAYWARD®



chlorinator

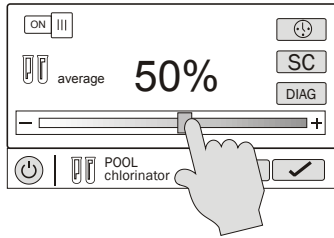

ORP Setting If ORP controls chlorination (page 10), adjust setpoint from 400mV to 900mV. If ORP does not control chlorination, adjust from 0% to 100%.

On/Off Enable and disable ORP sensing and chlorine generation.

Schedule Enable and disable chlorine generation based on time. You can set a unique schedule for the chlorinator that will override filter pump settings. See the OmniLogic manual for details on how to create schedules.

SC Superchlorinate allows you to select a continuous run time for maximum chlorination. Select a run time between 0-96 hours. The OmniLogic will override pump schedules and generate chlorine continuously for this amount of time.

Diag Displays electrical diagnostics for the Turbo Cell.

Controlling ORP with the OmniLogic

Follow these steps to adjust the desired ORP level:

1. **IMPORTANT:** Balance the pool water to the ideal levels shown in the OmniLogic manuals, including pH, total alkalinity, cyanuric acid, hardness and salt level.
2. Adjust the chlorine to the ideal level as well; e.g. 1-3 ppm free chlorine. This chlorine level is what we want to maintain.
3. After allowing the system to run for 30-60 minutes, observe what the Sense and Dispense system reports as the pool water ORP level.
4. Set the ORP setpoint setting to this reported ORP level.
5. Monitor the free chlorine and ORP every day for 1 week. If adjustments to the ORP setpoint are needed, make adjustments in increments of 10 or 20 mV units—**LARGE ADJUSTMENTS OF THE ORP SETPOINT SHOULD NOT BE NECESSARY IF YOU STARTED WITH A BALANCED**



HAYWARD®

POOL THAT HAD THE PROPER AMOUNT OF FREE CHLORINE.

6. If the system is not stabilizing (or does not seem to be stabilizing) there are 3 things you can do:
 - a. Clean the probe
 - b. Rebalance the pool—including the free chlorine level
 - c. Check for combined chlorine—if high (>0.5ppm), shock treat with chlorine or non-chlorine shock

Controlling pH with the OmniLogic

Plaster pools and pools serviced by salt-chlorine generators typically cause a slow pH rise which must be managed. With the Sense and Dispense technology, CO₂ or acid is dispensed into the filter system's return water as needed until the pH probe reports proper pH level.

The Hayward AQL-CHEM2(-240) are CO₂ dispensing systems that eliminate the need to handle acid and are economical and efficient methods for effective pH control. When the CO₂ gas is injected into water, it dissolves and becomes carbonic acid, a weak acid that is very effective at lowering pH but becomes self-limiting if over-fed.

CAUTION: IF YOU CHOOSE AN ACID FEEDER FOR pH CONTROL, additional safety precautions are required to ensure that an equipment malfunction is detected. Great care must be taken when installing, maintaining and operating acid pump feed systems. Acid is dangerous to handle, and will harm people and equipment if not properly contained, transported, poured, stored, and dispensed.

CAUTION: Equipment failure can potentially cause too much acid to be dispensed into the water, causing an equipment and health hazard which would not be detectable without the use of independent pH measurement.

- Always use a 4:1 dilution in the acid feed system.
- **CAUTION: To prevent a violent reaction, ALWAYS ADD ACID TO WATER, never add water to acid to dilute it. Some use the rhyme "Remember, do as you oughta- add acid to water"**
- Strictly follow the acid vendor's safety and handling protocols including hand, body and eye protection when transferring or handling acid.
- Choose a 5 gallon per day acid feed pump to keep flow rate low.
- Limit the available acid reservoir to 1 gallon per 15,000 gallons of water. This limits the available acid in the event that equipment malfunctions and empties the tank into the pool or spa.
- Only a properly installed and maintained system will control the pH and sanitizer levels of the water.
- **WARNING: If acid is not diluted properly or the feed pump is oversized, it will overshoot the pH correction.**
- At least monthly, use an independent pH and chlorine test kit to verify that pH and chlorine are at a safe level. If the probes are broken, depleted, dirty, fouled with oils, lotions, or other contaminants, they can report inaccurate result to the system causing incorrect water chemistry, which at worst, could harm people or equipment.
- Check the OmniLogic's display each day before entering the water. If there is an alarm, follow the troubleshooting guide to understand and rectify the condition. If the display is blank, or reporting a communications error, troubleshoot the equipment and rectify the failure before entering the water.



HAYWARD®

- Follow the installation checklist to verify proper operation upon installation and at the beginning of each pool season.

Maintenance

Water Chemistry

Always test water chemistry with a quality manual test kit. The HL-CHEM provides instrument grade accuracy which exceeds that of most liquid-standard water testing kits. Therefore, it may be preferable to calibrate pH using commercially available reference solutions. Calibrate pH periodically using the method described earlier in this manual. It's important to note that changes in pH, cyanuric acid concentration, total dissolved solids, and use of additional or alternative sanitizers will all affect the primary sanitizer residual level relative to ORP. Maintain total alkalinity on a regular basis to ensure pH stability. To maintain a consistent sanitizer residual in parts per million (ppm), periodically adjust the ORP level.

Probe Maintenance

The probes must be clean and free from oil, chemical deposits and contamination to function properly. After saturation in pool or spa water, the probes may need to be cleaned on a weekly or monthly basis depending on bather load and other pool specific characteristics. Slow response, increased need to calibrate pH, and inconsistent readings are indications that the probes are in need of cleaning.

To clean the probes without running the Wizard, turn off input power to the OmniLogic. Disconnect the probe connectors from the communication box, unscrew the probe and carefully remove them from the Probe Cell. Clean the reference junction (the white ring at the bottom of the probe body) with a soft toothbrush and regular tooth paste. A household liquid dishwashing detergent may also be used to remove any oil. Rinse with fresh water, replace teflon tape on threads and reinstall probes. If properly cleaned probes continue to provide unstable readings or require excessive calibration, the probes should be replaced.

Probe Storage

Exposure to atmospheric conditions will cause the probe tips to dry out. Store the probes with the included plastic probe storage caps if removed from the Probe Cell for more than one hour. If the storage caps have been misplaced, store the probes individually in small glass or plastic containers with clean water covering the probe tips. Store probes in a location that will not be subjected to freezing temperatures.

Winterizing

The HL-CHEM probes must be protected from freezing conditions. If the pool is winterized, plan to remove and store the probes (as described above) as part of the normal pool winterizing process. The Probe Cell and related plumbing must be drained as well. BNC connectors should be capped with the original protective covers. A winterizing kit with probe caps, BNC covers, and other necessary winterizing accessories is available to replace any missing items. Contact your local Hayward dealer for more information.



HAYWARD®

LIMITED WARRANTY (effective 03/01/12) Hayward warrants its Pro Logic, OnCommand and E-Command pool automation products as well as its Aqua Rite, Aqua Rite Pro, Aqua Plus and SwimPure chlorination products to be free of defects in materials and workmanship, under normal use and service, for a period of three (3) years. Hayward also warrants its Aqua Trol chlorination products to be free of defects in materials and workmanship, under normal use and service for a period of one (1) year. These warranties are applicable from the initial date of purchase on private residential swimming pools in the US and Canada. Installations of product for use on commercial pools in the US and Canada is covered for a period of one (1) year for defects in materials and workmanship. Hayward warrants all accessories and replacement parts for the above-identified pool automation and chlorination products for a period of one (1) year. Accessories also include remotes, actuators, base stations, temperature sensors, flow switches and chemistry probes. Each of these warranties is not transferable and applies only to the original owner.

Hayward shall not be responsible for cartage, removal, repair or installation labor or any other such costs incurred in obtaining warranty replacements or repair.

Proof of purchase is required for warranty service. If written proof of purchase is not provided, the manufacturing date code will be the sole determinant of the date of installation of the product. To obtain warranty service or repair, please contact the place of purchase or the nearest Hayward authorized warranty service center. For more information on authorized service centers please contact the Hayward Technical Service Support Center (61 Whitecap Road, North Kingstown RI, 02852) or visit the Hayward web site at www.hayward.com.

WARRANTY EXCLUSIONS:

1. Material supplied or workmanship performed by others in process of installation.
2. Damage resulting from improper installation including installation on pools larger than the product rating.
3. Problems resulting from failure to install, operate or maintain the product(s) in accordance with the recommendations contained in the owners manual(s).
4. Problems resulting from failure to maintain pool water chemistry in accordance with the recommendations in the owners manual(s).
5. Problems resulting from tampering, accident, abuse, negligence, unauthorized repairs or alternations, fire, flood, lightning, freezing, external water, degradation of natural stone used in or immediately adjacent to a pool or spa, war or acts of God.
6. Use of a non-genuine Hayward replacement salt chlorination cell on any Hayward automation or chlorination product will void the warranty for that product.

The express limited warranty above constitutes the entire warranty of Hayward Pool Products with respect to its products and is in lieu of all other warranties expressed or implied, including warranties of merchantability or fitness for a particular purpose. In no event shall Hayward Pool products be responsible for any consequential, special or incidental damages of any nature. Some states do not allow a limitation on how long an implied warranty lasts, or the exclusion of incidental or consequential damages, so the above limitation may not apply to you. This warranty gives you specific legal rights, and you may also have other rights, which vary from state to state.

For further information or consumer
technical support, visit our website at
www.hayward.com



Hayward is a registered trademark and OmniLogic and Sense and Dispense are trademarks of Hayward Industries, Inc. © 2013 Hayward Industries, Inc.

All other trademarks not owned by Hayward are the property of their respective owners. Hayward is not in any way affiliated with or endorsed by those third parties.

USE ONLY HAYWARD GENUINE REPLACEMENT PARTS



Wired Wall Mount Terminal

Touchscreen Terminal for OmniLogic

Owner's Manual

Contents

| | |
|--------------------|---|
| Description..... | 2 |
| Installation..... | 3 |
| Configuration..... | 6 |
| Operation..... | 6 |

HLWALLMOUNT

Hayward Pool Products
620 Division Street, Elizabeth NJ 07207
www.hayward.com



HAYWARD®

FCC Statement

This device complies with part 15 of the FCC rules. Operation is subject to the following two conditions: (1) This device may not cause harmful interference, and (2) this device must accept any interference received, including interference that may cause undesired operation.

Changes or modifications not expressly approved by Hayward could void the user's authority to operate this equipment.

NOTE: This equipment has been tested and found to comply with the limits for a Class B digital device, pursuant to Part 15 of the FCC Rules. These limits are designed to provide reasonable protection against harmful interference in a residential installation. This equipment generates, uses and can radiate radio frequency energy and, if not installed and used in accordance with the instructions, may cause harmful interference to radio communications. However, there is no guarantee that interference will not occur in a particular installation. If this equipment does cause harmful interference to radio or television reception, which can be determined by turning the equipment off and on, the user is encouraged to try to correct the interference by one or more of the following measures:

- Reorient or relocate the receiving antenna.
- Increase the separation between the equipment and receiver.
- Connect the equipment into an outlet on a circuit different from that to which the receiver is connected.
- Consult the dealer or an experienced radio / TV technician for help.

Industry Canada Statement

This Class B digital apparatus complies with Canadian ICES-003.

Cet appareil numérique de la classe B est conforme à la norme NMB-003 du Canada.

The term "IC" before the certification / registration number only signifies that the Industry Canada technical specifications were met.



Description

The HLWALLMOUNT is a remote touchscreen terminal that wires directly to the OmniLogic pool automation controller. It is designed to fasten to a wall giving the user convenient access for monitoring and controlling their pool. Up to two HLWALLMOUNTs can be installed and connected to the OmniLogic. After installation, the OmniLogic will detect the new HLWALLMOUNT(s) and automatically configure itself to utilize the new terminal(s).

Compatibility

The HLWALLMOUNT is compatible with all OmniLogic pool controls.

Before You Begin

Included:

- HLWALLMOUNT Remote Terminal

What you'll need:

- mounting screws/anchors
- an appropriate length of 4 conductor, 20 - 24AWG twisted pair wire (CAT3 or better preferred but not mandatory) for connecting the HLWALLMOUNT to the OmniLogic
- wirecutter/wirestripper
- tools for mounting, small flathead screwdriver for screw terminals

The HLWALLMOUNT must be mounted indoors or in a weather protected area (rain should never be in contact with the touchscreen).

When considering a potential mounting location, survey the wiring route from the OmniLogic to the HLWALLMOUNT. Ensure that you can successfully run an uninterrupted length of 4 conductor wire. Although various types of wire can be used, 4 conductor, solid 22AWG phone cable is recommended. Refer to the table below for limitations on wire run lengths. When selecting a location, note that the connecting the OmniLogic to the HLWALLMOUNT must not exceed the recommended lengths shown in the chart below.

Up to two HLWALLMOUNTs can be wired to the OmniLogic. If wired in parallel, both units can be wired up to the maximum distance shown below. If daisy chained, the furthest unit can not exceed the maximum distance shown below.

| | 20 AWG | 22AWG | 24AWG |
|-------------------------|--------------|-------------|-------------|
| Maximum Distance | 450ft / 140m | 285ft / 85m | 180ft / 55m |



HAYWARD®

Installation

DANGER of Death, Injury or Property Damage if procedure not followed. This accessory connects to the OmniLogic panel beneath the dead front. Dead front removal is required for this installation. Power to the OmniLogic panel **MUST** be shut off before the dead front is removed. This means a complete shutdown of power to the entire OmniLogic panel.

Remove power to the OmniLogic. Remove the OmniLogic cover panel (dead front) to expose the main board and internal relays.

Mounting

1. Remove the remote terminal wallplate from the cover by inserting a screwdriver in the slot shown below. Lift up on the cover while pushing gently with the screwdriver.

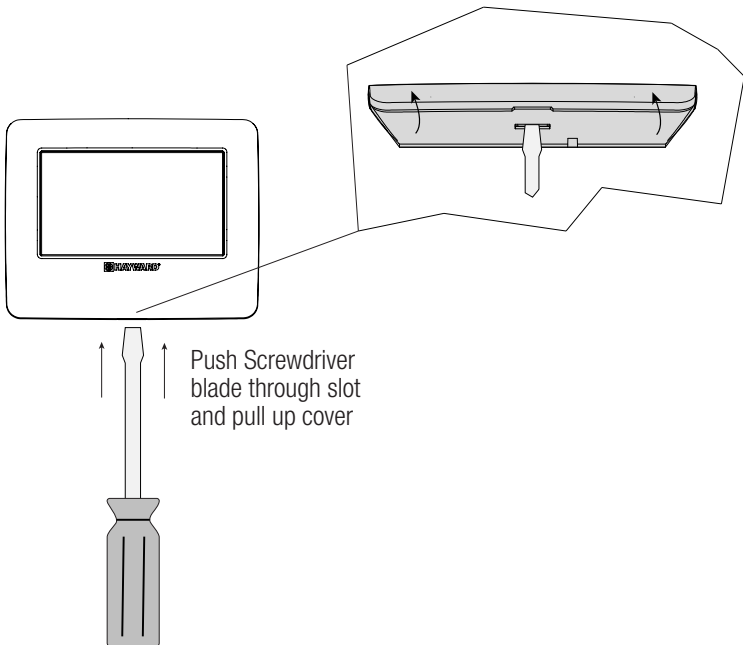



HAYWARD®

2. Fasten the wallplate at the desired location (screws supplied by installer).

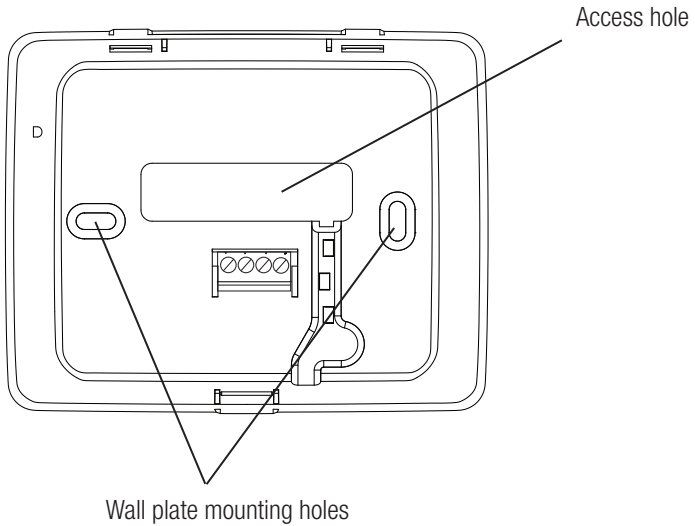

Wiring

Use four conductor cable (typically phone cable) to connect the remote display keypad with the OmniLogic Main Board as shown below. Refer to the chart on page 1 for maximum wire length.

For a clean "cable free" look, route the cable so that it exits the mounting surface and enters through the access hole in the wallplate.

Connect the cable to the high speed RS-485 screw terminals on the OmniLogic and HLWALL-MOUNT as shown below. The screw terminals are numbered on both units. Connect 1 to 1, 2 to 2, etc. Screw terminal #5 is not used on the OmniLogic.

Up to two HLWALLMOUNTs can be installed in parallel or daisy chained. In both cases, never connect more than two wires to any terminal block.

Parallel: Two HLWALLMOUNTs are wired back to the OmniLogic main unit (connection made at OmniLogic) and both can be at the maximum distance.



HAYWARD®

Daisy Chain: The second (furthest) HLWALLMOUNT is wired to the first (connection made at first HLWALLMOUNT) and the second HLWALLMOUNT must not exceed the maximum distance from OmniLogic. Connect 1 to 1, 2 to 2, etc.

After wiring is complete, reinstall the HLWALLMOUNT cover. Reinstall the OmniLogic dead front and restore power to the OmniLogic.

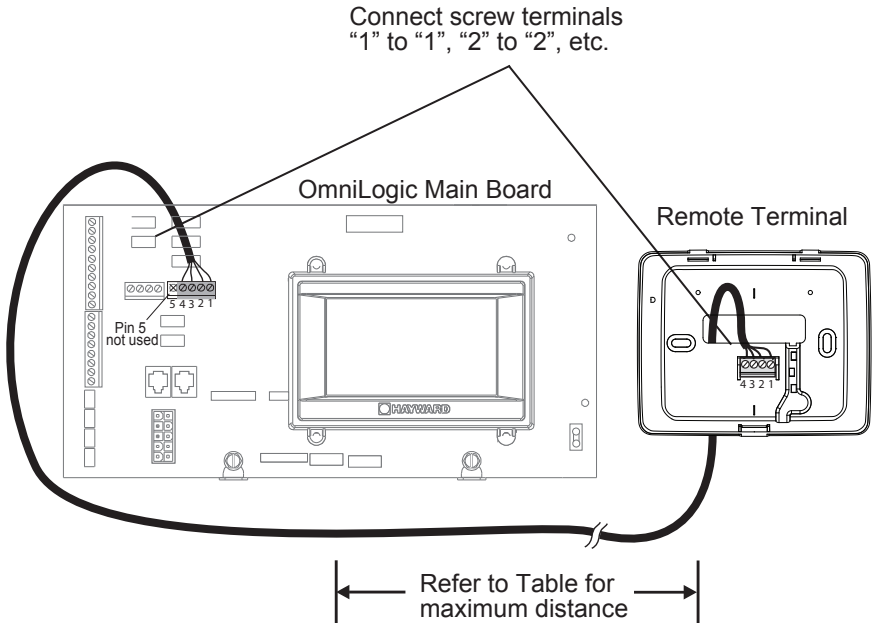

Configuration

When the OmniLogic first starts HLWALLMOUNT should automatically be discovered and configured. No input is required from the user. To verify that the OmniLogic has discovered the HLWALLMOUNT, go to the local terminal (touchscreen on the OmniLogic) and follow the procedure below. There should be a line entry showing the HUA and version.

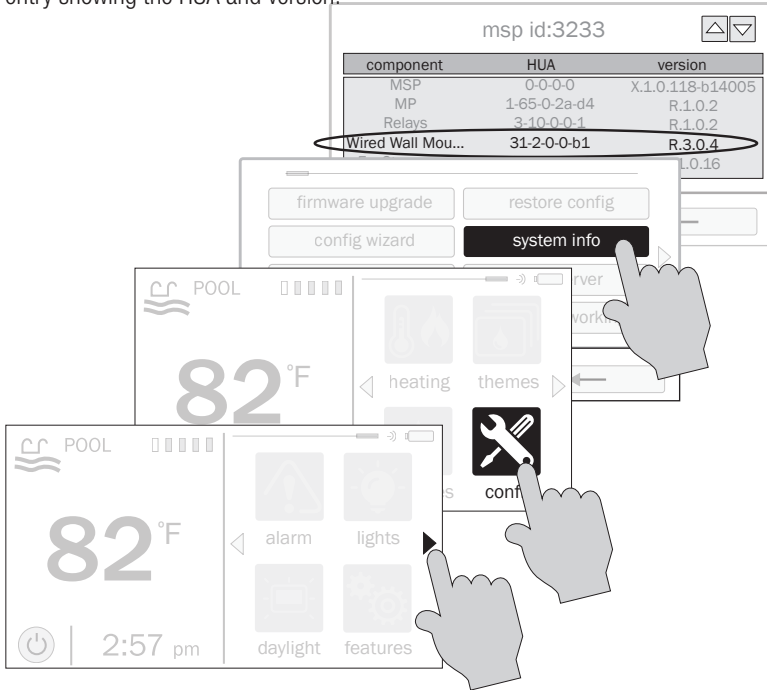

Operation

The HLWALLMOUNT provides the same functionality as the Local Terminal except for the following:

- No Service Mode - Service mode is only accessible from the Local Terminal
- Limited Configuration options - Full access to all OmniLogic configuration settings is only available at the Local Terminal.

For further information or consumer
technical support, visit our website at
www.hayward.com



HAYWARD®



Hayward is a registered trademark and OmniLogic is
a trademark of Hayward Industries, Inc. © 2013 Hayward Industries, Inc.

All other trademarks not owned by Hayward are the property of their respective owners.
Hayward is not in any way affiliated with or endorsed by those third parties.

USE ONLY HAYWARD GENUINE REPLACEMENT PARTS



Relay Bank

Relay Kit for OmniLogic

Owner's Manual

Contents

| | |
|--------------------|---|
| Description..... | 2 |
| Installation..... | 2 |
| Configuration..... | 4 |

HLRELAYBANK

Hayward Pool Products
620 Division Street, Elizabeth NJ 07207
www.hayward.com



HAYWARD®

FCC Statement

This device complies with part 15 of the FCC rules. Operation is subject to the following two conditions: (1) This device may not cause harmful interference, and (2) this device must accept any interference received, including interference that may cause undesired operation.

Changes or modifications not expressly approved by Hayward could void the user's authority to operate this equipment.

NOTE: This equipment has been tested and found to comply with the limits for a Class B digital device, pursuant to Part 15 of the FCC Rules. These limits are designed to provide reasonable protection against harmful interference in a residential installation. This equipment generates, uses and can radiate radio frequency energy and, if not installed and used in accordance with the instructions, may cause harmful interference to radio communications. However, there is no guarantee that interference will not occur in a particular installation. If this equipment does cause harmful interference to radio or television reception, which can be determined by turning the equipment off and on, the user is encouraged to try to correct the interference by one or more of the following measures:

- Reorient or relocate the receiving antenna.
- Increase the separation between the equipment and receiver.
- Connect the equipment into an outlet on a circuit different from that to which the receiver is connected.
- Consult the dealer or an experienced radio / TV technician for help.

Industry Canada Statement

This Class B digital apparatus complies with Canadian ICES-003.

Cet appareil numérique de la classe B est conforme à la norme NMB-003 du Canada.

The term "IC" before the certification / registration number only signifies that the Industry Canada technical specifications were met.



HAYWARD®

Description

The HLRELAYBANK is a relay kit accessory for all OmniLogic pool controls. It offers four additional high voltage internal relays to control various pool and backyard equipment. After installation, the OmniLogic will detect the HLRELAYBANK and, using the OmniLogic's CONFIGURATION WIZARD, allow you to configure the relays to control your pool and backyard equipment.

RELAY: 3HP/30A at 240V (1½HP/30A at 120V)

Installation

DANGER of Death, Injury or Property Damage if procedure not followed. This accessory connects to the OmniLogic panel beneath the dead front. Dead front removal is required for this installation. Power to the OmniLogic panel **MUST** be shut off before the dead front is removed. This means a complete shutdown of power to the entire OmniLogic panel.

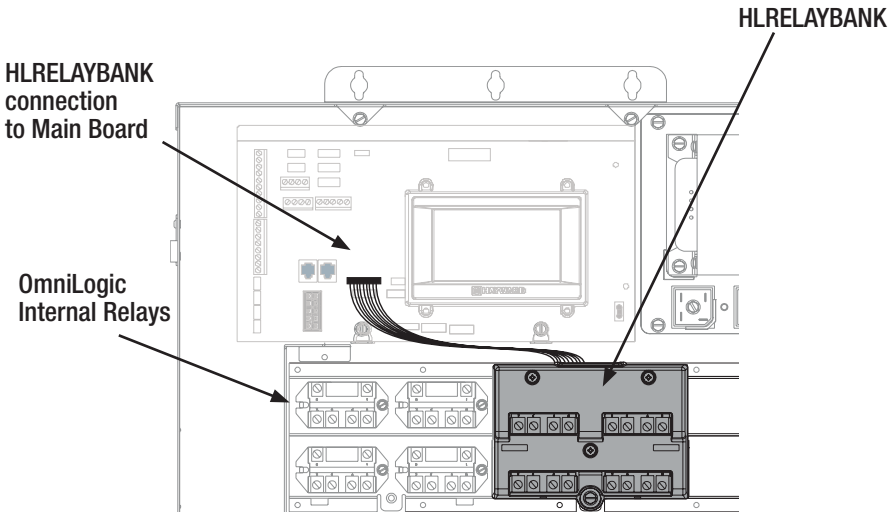



HAYWARD®

Installing the HLRELAYBANK

The HLRELAYBANK has two hooks on the back of its enclosure. These hooks will fit into slots on a rail inside of the OmniLogic as shown below. Once fitted on the rail, a screw will secure the relay bank to the OmniLogic.

1. Ensure that power has been removed to the OmniLogic.
2. Remove the OmniLogic dead front to expose the main board and internal relays.
3. Referring to the installation location shown on page 2. Slide the HLRELAYBANK's hooks into the OmniLogic rail and secure by tightening the bottom screw.
4. Route the wire harness as shown on page 2 and secure the connector into the main board.
5. Replace OmniLogic dead front and turn power on.

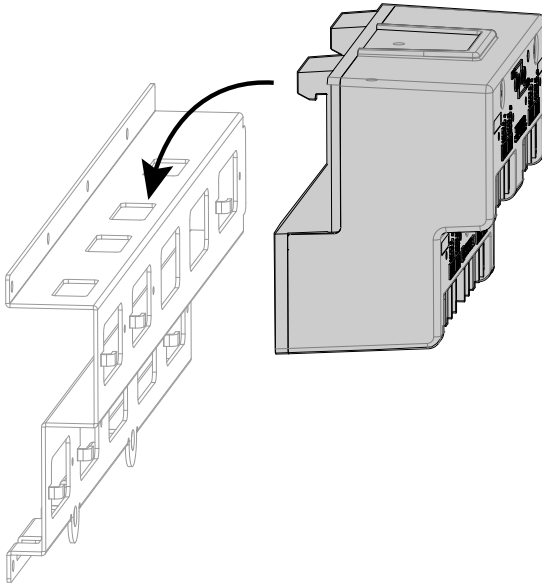



Configuration

The OmniLogic will automatically discover the HLRELAYBANK at power up. The four relays will be displayed in the Relay Table located in the OmniLogic's CONFIGURATION WIZARD. The relays will be displayed as "HVR5-HVR8" in the table as shown below.

HLRELAYBANK
relays

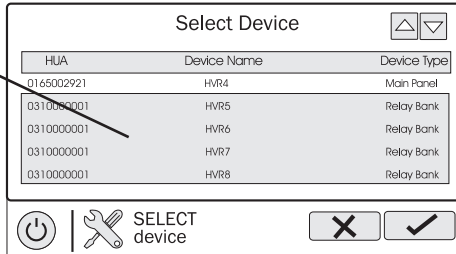

Note that the device name in the relay table corresponds to the following relays on the HLRELAY-BANK:

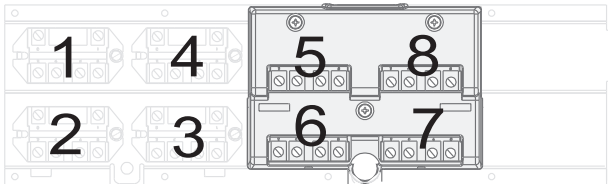

High Voltage Wiring

Refer to the OmniLogic Installation manual for detailed instructions on how to wire and assign relays to your pool's equipment.



HAYWARD®



HAYWARD®

For further information or consumer
technical support, visit our website at
www.hayward.com



Hayward is a registered trademark and OmniLogic is
a trademark of Hayward Industries, Inc. © 2013 Hayward Industries, Inc.

All other trademarks not owned by Hayward are the property of their respective owners.
Hayward is not in any way affiliated with or endorsed by those third parties.

USE ONLY HAYWARD GENUINE REPLACEMENT PARTS



HLRelay

High Voltage Relay for OmniLogic

Owner's Manual

Contents

| | |
|--------------------|---|
| Description..... | 1 |
| Installation..... | 2 |
| Configuration..... | 3 |

HLRELAY

Hayward Pool Products
620 Division Street, Elizabeth NJ 07207
www.hayward.com



HAYWARD®

FCC Statement

This device complies with part 15 of the FCC rules. Operation is subject to the following two conditions: (1) This device may not cause harmful interference, and (2) this device must accept any interference received, including interference that may cause undesired operation.

Changes or modifications not expressly approved by Hayward could void the user's authority to operate this equipment.

NOTE: This equipment has been tested and found to comply with the limits for a Class B digital device, pursuant to Part 15 of the FCC Rules. These limits are designed to provide reasonable protection against harmful interference in a residential installation. This equipment generates, uses and can radiate radio frequency energy and, if not installed and used in accordance with the instructions, may cause harmful interference to radio communications. However, there is no guarantee that interference will not occur in a particular installation. If this equipment does cause harmful interference to radio or television reception, which can be determined by turning the equipment off and on, the user is encouraged to try to correct the interference by one or more of the following measures:

- Reorient or relocate the receiving antenna.
- Increase the separation between the equipment and receiver.
- Connect the equipment into an outlet on a circuit different from that to which the receiver is connected.
- Consult the dealer or an experienced radio / TV technician for help.

Industry Canada Statement

This Class B digital apparatus complies with Canadian ICES-003.

Cet appareil numérique de la classe B est conforme à la norme NMB-003 du Canada.

The term "IC" before the certification / registration number only signifies that the Industry Canada technical specifications were met.

Description

The HLRELAY is a single high voltage relay accessory for the HLBASE OmniLogic pool control. Although the HLBASE comes with four high voltage relays, up to two HLRELAYS can be added to control additional pool and backyard equipment. After installation, the OmniLogic will detect the HLRELAY(s) and, using the OmniLogic's CONFIGURATION WIZARD, allow you to configure the relay(s) to control your pool equipment.

RELAY: 3HP/30A at 240V (1½HP/30A at 120V)



Installation

DANGER of Death, Injury or Property Damage if procedure not followed. This accessory connects to the OmniLogic panel beneath the dead front. Dead front removal is required for this installation. Power to the OmniLogic panel **MUST** be shut off before the dead front is removed. This means a complete shutdown of power to the entire OmniLogic panel.

If using a single HLRELAY, install it in the 9th relay position. For two relays, use both the 9th and 10th locations. Relay positions are shown on the diagram on page 2.

1. Shut off power to the OmniLogic System Panel and remove the deadfront.
2. Mount the relay in the proper position by sliding one of the relay mounting holes over the hook on the System Panel. Fasten the relay with the included mounting screw through the other mounting hole. Refer to diagram.
3. Route the connector at the end of the HLRELAY wiring harness to the appropriate connector on the OmniLogic Main Board as shown below.

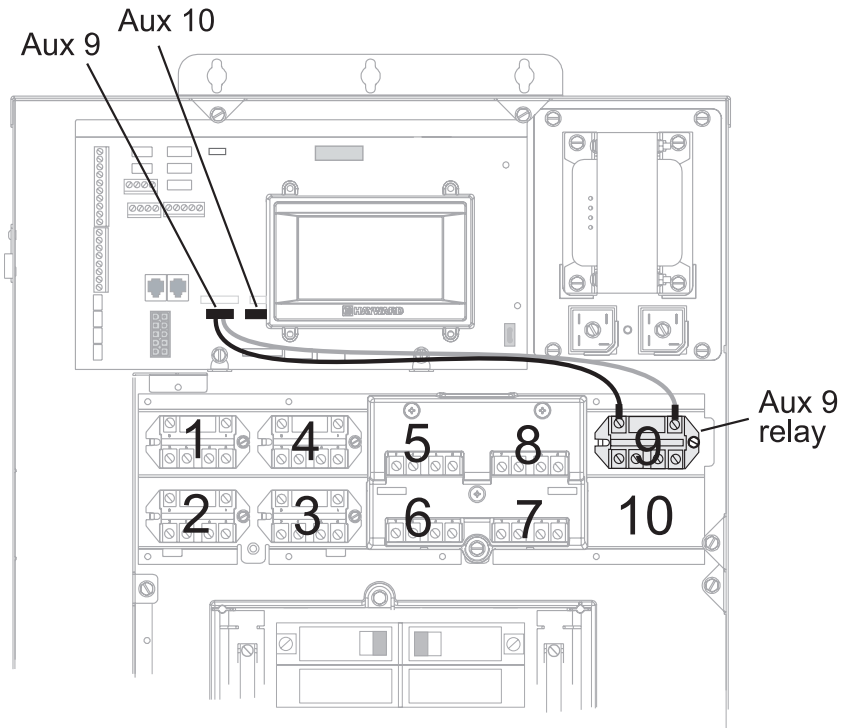

4. Replace deadfront and power up the OmniLogic.



Configuration

The OmniLogic will automatically discover the HLRELAY(s) at power up. The relay(s) will be displayed in the Relay Table located in the OmniLogic's CONFIGURATION WIZARD. A single relay will be displayed as "HVR9". If using two HLRELAYS, the table will show "HVR9" and "HVR10".

HLRELAY relays

Select Device ▲ ▼

| HUA | Device Name | Device Type |
|------------|-------------|-------------|
| 0310000001 | HVR7 | Relay Bank |
| 0310000001 | HVR8 | Relay Bank |
| 0310000001 | HVR9 | HLRelay |
| 0310000001 | HVR10 | HLRelay |

  SELECT device ✕ ✓

High Voltage Wiring

Refer to the OmniLogic Installation manual for detailed instructions on how to wire and assign relays to your pool's equipment.

For further information or consumer technical support, visit our website at www.hayward.com



Hayward is a registered trademark and OmniLogic is a trademark of Hayward Industries, Inc. © 2013 Hayward Industries, Inc.

All other trademarks not owned by Hayward are the property of their respective owners. Hayward is in no way affiliated with or endorsed by those third parties.



Input/Output Expander

for OmniLogic

Owner's Manual

Contents

| | |
|--------------------|---|
| Description..... | 2 |
| Installation..... | 2 |
| Configuration..... | 6 |

HLIOEXPAND

Hayward Pool Products
620 Division Street, Elizabeth NJ 07207
www.hayward.com



HAYWARD®

FCC Statement

This device complies with part 15 of the FCC rules. Operation is subject to the following two conditions: (1) This device may not cause harmful interference, and (2) this device must accept any interference received, including interference that may cause undesired operation.

Changes or modifications not expressly approved by Hayward could void the user's authority to operate this equipment.

NOTE: This equipment has been tested and found to comply with the limits for a Class B digital device, pursuant to Part 15 of the FCC Rules. These limits are designed to provide reasonable protection against harmful interference in a residential installation. This equipment generates, uses and can radiate radio frequency energy and, if not installed and used in accordance with the instructions, may cause harmful interference to radio communications. However, there is no guarantee that interference will not occur in a particular installation. If this equipment does cause harmful interference to radio or television reception, which can be determined by turning the equipment off and on, the user is encouraged to try to correct the interference by one or more of the following measures:

- Reorient or relocate the receiving antenna.
- Increase the separation between the equipment and receiver.
- Connect the equipment into an outlet on a circuit different from that to which the receiver is connected.
- Consult the dealer or an experienced radio / TV technician for help.

Industry Canada Statement

This Class B digital apparatus complies with Canadian ICES-003.

Cet appareil numérique de la classe B est conforme à la norme NMB-003 du Canada.

The term "IC" before the certification / registration number only signifies that the Industry Canada technical specifications were met.



HAYWARD®

Description

The HLIOEXPAND is an expander board accessory for all OmniLogic pool controls. It offers four additional temperature sensor inputs, pool/spa valve actuator outputs and low voltage (dry contract) outputs to control various pool and backyard equipment. After installation, the OmniLogic will detect the HLIOEXPAND and allow you to configure the additional input/outputs to control and/or monitor your pool and backyard equipment.

SENSOR INPUT: Use only Hayward 10k ohm thermistor type temperature sensors (not included). Hayward recommends the multipurpose "PC" sensor available at local Hayward dealers.

VALVE ACTUATOR OUTPUT: 24 VAC, 0.55 A, fuse protected

LOW VOLTAGE DRY CONTACT RELAY: 24 VAC, 0.5 A max

Installation

DANGER of Death, Injury or Property Damage if procedure not followed. This accessory connects to the OmniLogic panel beneath the dead front. Dead front removal is required for this installation. Power to the OmniLogic panel **MUST** be shut off before the dead front is removed. This means a complete shutdown of power to the entire OmniLogic panel.

Overview

The HLIOEXPAND is design to slide between guide rails and insert into a dedicated slot on the OmniLogic main board. Once inserted, the OmniLogic will discover the HLIOEXPAND and its inputs/outputs can be configured within the OmniLogic's CONFIGURATION WIZARD.

There are two "locking" positions when sliding the HLIOEXPAND between the OmniLogic's guide rails. The first position will hold the board in place to allow easy access to wire sensors, valves, and low voltage equipment. Once all connections are made, slide the HLIOEXPAND further into the second position. The HLIOEXPAND should insert firmly into the OmniLogic main board's slot and lock in place.



HAYWARD®

Lock HLIOEXPAND into Position 1

1. Remove power to the entire OmniLogic panel.
2. Remove the OmniLogic deadfront to expose the main board and relays.
3. Slide the HLIOEXPAND between the guide rails until it locks as shown below. In this position, the board will be sticking out from the enclosure allowing access to the wiring connections on the HLIOEXPAND.

Position 1
Insert HLIOEXPAND board
until the guide rails clips into
the first notch.

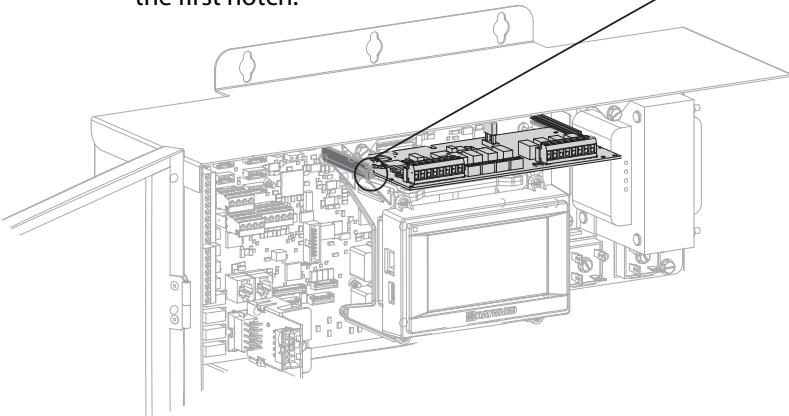
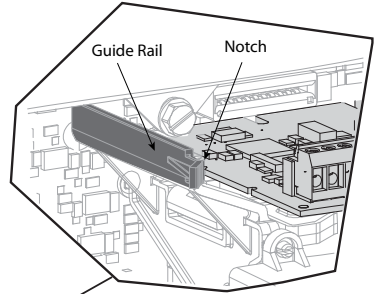

Wiring

Refer to the diagram below for the location of the wiring connectors for temperature sensors, valve actuators and low voltage pool/spa equipment. For detailed information about wiring these components, Low Voltage Wiring section of the OmniLogic Installation manual.

When making these connections, be aware that wires should be routed to the low voltage side of the OmniLogic. Taking care when routing wires will help prevent the possibility of pinching a wire when re-mounting the panel.

After all connections have been made, use wire anchors and ties to secure the bundle of wires coming from the HLIEXPAND. Two anchors (with adhesive back) and two nylon ties straps are provided. When determining a location to mount the anchors, be sure to position wiring below the deadfront and above the OmniLogic's main board.

Note that the actuator outputs are protected by a 4 amp "automotive" type fuse. This fuse can be replaced if necessary.

4A replaceable fuse

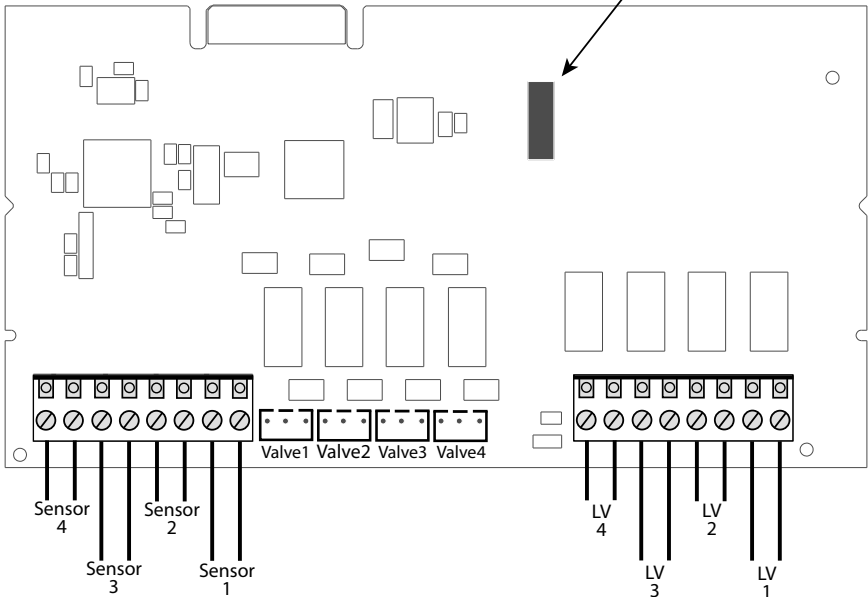



HAYWARD®

Lock HLIOEXPAND into Position 2

1. With all the wires attached, slide the HLIOEXPAND between the guide rails until it locks into position 2 as shown below. If the board is difficult to slide, you may have to spread the guide rails slightly to release the board from position 1.
2. Replace the OmniLogic deadfront and fasten.
3. Restore power to the OmniLogic.

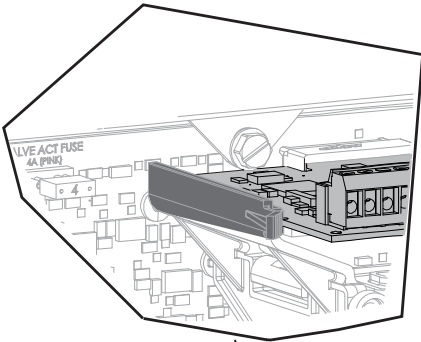

Position 2

Slide the HLIOEXPAND board all the way until it inserts firmly into the OmniLogic main board's slot. The guide rails will lock as shown.

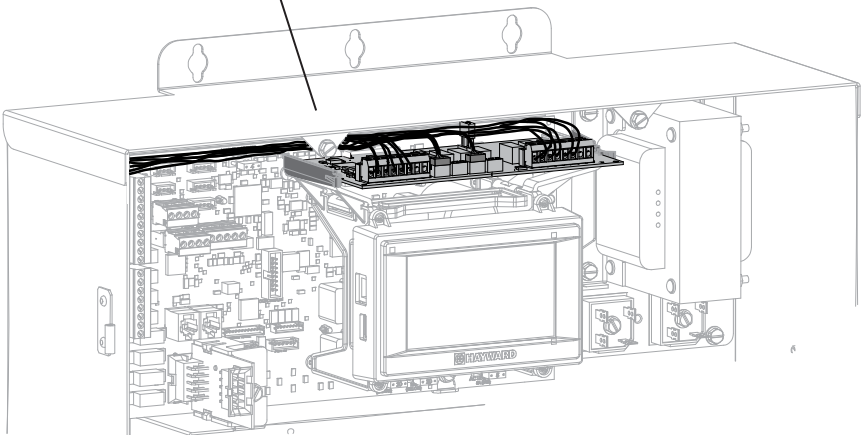



HAYWARD®

Configuration

The HLIOEXPAND will be automatically discovered at power up and can be found in the CONFIGURATION WIZARD. As you progress through the wizard, the four additional valve outputs, low voltage outputs, and temperature sensor inputs will all be displayed in their corresponding tables. They can be easily identified by looking for "IO Module" under "Device Type" in the tables (as shown below). Refer to the OmniLogic Installation Manual for details on how to configure valve outputs, low voltage outputs and temperature sensor inputs.

HLIOEXPAND VALVES

Select Device ▲ ▼

| HUA | Device Name | Device Type |
|------------|-------------|-------------|
| 0165002a9a | VLV4 | Main Panel |
| 0410000001 | VLV1 | IO Module |
| 0410000001 | VLV2 | IO Module |
| 0410000001 | VLV3 | IO Module |
| 0410000001 | VLV4 | IO Module |

⏻
🔧 SELECT device
✖
✔

HLIOEXPAND Low Voltage Output

Select Device ▲ ▼

| HUA | Device Name | Device Type |
|------------|-------------|-------------|
| 0165002a9a | LVR4 | Main Panel |
| 0410000001 | LVR1 | IO Module |
| 0410000001 | LVR2 | IO Module |
| 0410000001 | LVR3 | IO Module |
| 0410000001 | LVR4 | IO Module |

⏻
🔧 SELECT device
✖
✔

HLIOEXPAND Temperature Sensors

Select Device ▲ ▼

| HUA | Device Name | Device Type |
|------------|---------------|-------------|
| 0165002a9a | SNS5 (DE SPA) | Main Panel |
| 0410000001 | SNS1 | IO Module |
| 0410000001 | SNS2 | IO Module |
| 0410000001 | SNS3 | IO Module |
| 0410000001 | SNS4 | IO Module |

⏻
🔧 SELECT device
✖
✔

For further information or consumer
technical support, visit our website at
www.hayward.com



Hayward is a registered trademark and OmniLogic is
a trademark of Hayward Industries, Inc. © 2013 Hayward Industries, Inc.

All other trademarks not owned by Hayward are the property of their respective owners.
Hayward is not in any way affiliated with or endorsed by those third parties.

USE ONLY HAYWARD GENUINE REPLACEMENT PARTS