

VGreen[®] 165

VARIABLE SPEED USER MANUAL

Premium Efficiency Variable Speed Motor



A Regal Brand

COPYRIGHT

Copyright 2016, Regal Beloit America, Inc.
Tipp City, Ohio. All rights reserved.

TRADEMARKS

All trademarks and registered trademarks® are the property of their respective companies. The information in this document incorporates proprietary rights and is not to be duplicated wholly or in part without the express written permission of Regal Beloit Corporation and / or Regal Beloit America, Inc.

January 2016/USA

Table of Contents

Safety	2
1. Introduction	3
2. Navigation Overview	3
3. Quick Start Instruction	5
3.1 Quick Start Guide (Using Factory Default Schedule)	5
3.2 Quick Start Guide (User Defined Custom Schedule)	6
4. Overview	8
5. Wiring	9
6. User Interface Operation	12
6.1 LED and Function Overview	12
6.2 User Interface Key Pad Overview	13
6.3 Set the Schedule	13
6.4 Running VGreen 165 from Key Pad	15
6.5 OVERRIDE	17
6.6 Schedule Advance	18
6.7 Key Lockout	20
6.8 Motor Pause	21
6.9 Temporary Stop with Digital / Serial Input	21
6.10 Reset Factory Defaults	22
7. Priming	22
8. Freeze Protection	22
9. Control with Digital Inputs	23
10. DIP Switches	24
11. Care and Maintenance	25
12. FAULT Status	25
13. Specifications	27
14. Troubleshooting Guide	28

SAFETY

Safety is emphasized throughout this user manual. These are safety alert symbols and signal words. They alert the user to potential personal injury hazards. Obey all safety messages to avoid possible injury or death or damage to equipment and other property.

DANGER



DANGER indicates a hazardous situation which, if not avoided, will result in death or serious injury.

WARNING



WARNING indicates a hazardous situation which, if not avoided, could result in death or serious injury.

CAUTION



CAUTION indicates a hazardous situation which, if not avoided, could result in minor or moderate injury.

NOTICE



NOTICE identifies potential equipment damage or failure conditions and alerts personnel to potentially dangerous situations.

1 Introduction

The VGreen® 165 is a premium efficiency variable speed motor that provides tremendous program flexibility in terms of motor speed and time settings. The variable speed VGreen 165 is intended to enable running at the lowest speeds needed to maintain a sanitary environment, which in turn minimizes energy consumption. Pool size, the presence of additional water features, chemicals used to maintain sanitary conditions, and environmental factors will impact optimal programming necessary to maximize energy conservation.

⚠ WARNING

The VGreen 165 is for use with 208-230 Vrms nominal, and in pool pump applications ONLY. Connection to the wrong voltage, or use in other application may cause damage to equipment or personal injury.

The integrated electronics interface controls the speed settings as well as the run durations. The VGreen 165 can run at speeds ranging between 600 and 3450 RPM and is rated for 208-230 Vrms at an input frequency of 60 Hz.

2 Navigation Overview

- +, - Increases/decreases selected value
- Pressing any key following a change accepts the current value displayed inside the setting

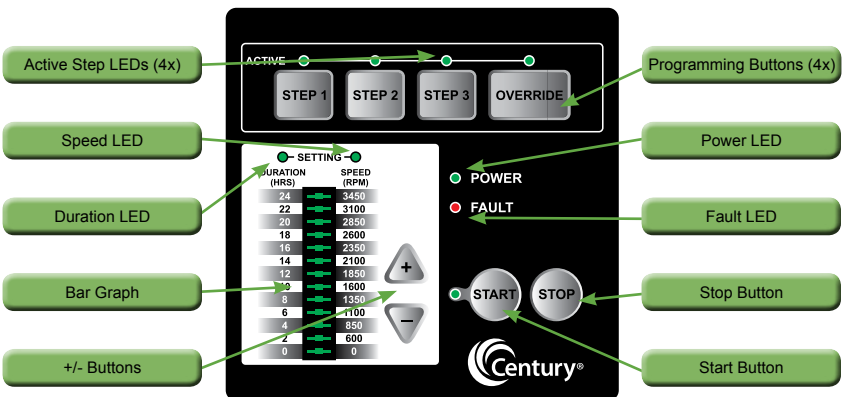

Figure 1: VGreen 165 User Interface Button Descriptions

⚠ CAUTION

If power is connected to the VGreen 165 motor, pressing any of the following buttons referred to in section 2 could result in the motor starting. Failure to recognize this could result in personal injury or damage to equipment.

Note: The START button must be pressed for the VGreen 165 to operate. The START LED will illuminate after the button has been pressed indicating the VGreen 165 is capable of operating. Pressing the stop button will turn off the START LED and stop the motor if running.

VGreen 165 Features

- Simple user interface
- Digital inputs for compatibility with pool automation systems
- Motor design reduces noise emissions
- UV and rain-proof enclosure
- Freeze Protection
- Manual OVERRIDE
- Compatibility w/ VGreen 270 user interface
(sold as a separate accessory)
- High efficiency electromechanical motor and control design

Benefits of adding an optional VGreen 270 user interface with the VGreen 165 motor

- Ability to conduct field troubleshooting (i.e., view FAULT codes and real time operating parameters).
- Ability to set a pump running schedule based on a real clock setting (i.e., must input actual time which then determines pump start and stop times).
- Ability to remotely mount the VGreen 270 user interface (provides easy access of user interface depending on pump location).
- Ability to configure **prime speed** and **prime duration**.

- Ability to configure **freeze protection** temperature.
- Ability to view actual speed and power of the VGreen 165 in real time.
- Ability to adjust the VGreen 165 motor speed in 25 RPM increments (to fine tune flow for certain pool installations).
- Battery backup to store time setting.

3 Quick Start Instruction

⚠ CAUTION

If power is connected to the VGreen 165 motor, pressing any of the following buttons referred to in section 3 could result in the motor starting. Failure to recognize this could result in personal injury or damage to equipment.

3.1 Quick Start Guide (Using the factory default schedule)

The following table describes the factory default settings for DURATION and SPEED order:

Button	Duration (In Hours)	Speed (In RPM)
STEP 1	4	3100
STEP 2	4	2600
STEP 3	8	1600
OVERRIDE	2	3450

Pressing the START key will start the VGreen 165 based on the factory default schedule.

NOTE: If power is cycled to the VGreen 165 and the user does not press the STOP key, the VGreen 165 will **automatically** start and run the programmed default schedule shown in the chart above. This feature ensures that the VGreen 165 will re-start in the event of a power outage.

3.2 Quick Start Guide (User-defined custom schedule)

A VGreen 165 user can set the program DURATION and SPEED for STEP 1, STEP 2, STEP 3 & OVERRIDE keys.

NOTE: VGreen 165 must be **Stopped (Press STOP Key)** for programming DURATION and SPEED of the STEP 1, STEP 2, and STEP 3 keys. OVERRIDE DURATION and SPEED can be programmed when the VGreen 165 is **either** stopped or running.

Press the STEP 1 key. The STEP 1 button and DURATION setting LEDs will illuminate. The bar graph will show default DURATION for STEP 1.

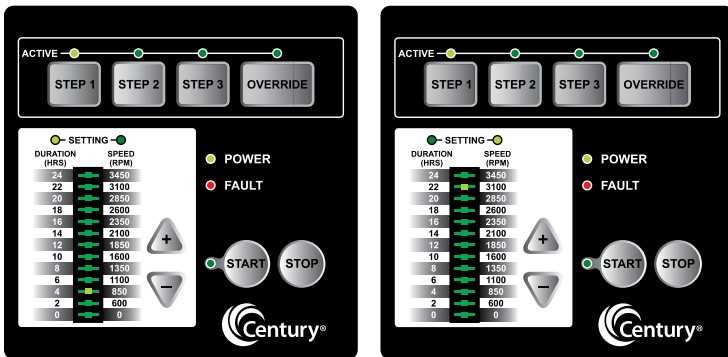

1. Press UP (+) or DOWN (-) arrows to change the DURATION
2. Press the STEP 1 key again to change the SPEED setting. The SPEED setting LED will illuminate. The bar graph will show default SPEED for STEP 1.
3. Press UP (+) or DOWN (-) arrows to change the SPEED.
4. Press any STEP or OVERRIDE key to save the DURATION and SPEED settings for STEP 1. If the user decides not to save the settings, pressing the STOP key will revert back to the previously stored setting.

5. Press STEP 2, STEP 3, or OVERRIDE key. Repeat steps 1- 4 to program the corresponding DURATION and SPEED for each button.
6. Press START to run the VGreen 165 based on the programmed 24 hour schedule.
7. Pressing the STOP button will stop the VGreen 165.

NOTE: The VGreen 165 can only be set to operate on a 24-hour schedule. If a user attempts to program a schedule with a combined duration for all three steps greater than 24 hours, the VGreen 165 software will retain the current STEP time duration only, and will zero out the other two STEP time settings. As an example, if STEP 1 equals eight (8) hours, STEP 2 equals nine (9) hours, and STEP 3 equals eight (8) hours – for a combined 25 hours – the VGreen 165 will retain the setting for the current Step being programmed and zero out the remaining two. For details regarding the set-up of the three steps as part of a 24-hour schedule, see section 6.

4 Overview

NOTICE

The VGreen 165 can and should be optimized to suit individual pool conditions. Specific conditions including pool size, other devices, features, and environmental factors can all impact the optimal settings.

Program customization may require some trial-and-error to determine the most satisfactory settings as dictated by the conditions. In all cases, setting the VGreen 165 at the lowest speed for the longest duration is the best strategy to minimize energy consumption. However, conditions may require running the VGreen 165 at a higher speed for some duration of time each day to maintain proper filtration to achieve satisfactory sanitation.

The User Interface is located on top of the VGreen 165. To the right of the STEP buttons is the OVERRIDE button. This button can be used to operate the VGreen 165 at speeds outside of the normal operating schedule.



Figure 2: VGreen 165 Overview

5 Wiring

⚠ WARNING

The VGreen 165 controller must be wired according to the locally adopted version of the NEC. A licensed, qualified electrician should complete the wiring for this product. Failure to comply with this may result in death, serious personal injury or property damage.

The VGreen 165 controller must be wired according to the locally adopted version of the NEC. A licensed, qualified electrician should complete the wiring for this product.

The controller is designed to operate with 208-230 Vrms, single phase power.

The VGreen 165 is designed to handle either a bare wire connection or a quick disconnect connection. The quick disconnect tab is 0.250" and will handle any commonly available mating connectors. For a direct wire connection, the wire insulation should be stripped to a length of approximately 0.33." The terminal block is capable of handling solid or stranded wire up to 12 AWG in size. The screw for the mains connections should be properly tightened to a torque value of 10 in-lb.

Pin #	Wire Color	Description
L1	Black	Hot 1
L2	Red or White	Hot 2
Green screw	Green	Earth

Table 1: Mains Connection

Pin #	Wire Color	Description
J201 - 1	Red	+12V
J201 - 2	Black	A
J201 - 3	Yellow	B
J201 - 4	Green	COM

Table 2: Communication Connection

⚠ WARNING

Power should be turned off when installing, servicing, or repairing electrical components. Observe all warning notices posted on the existing equipment, VGreen 165, and in these installation instructions.

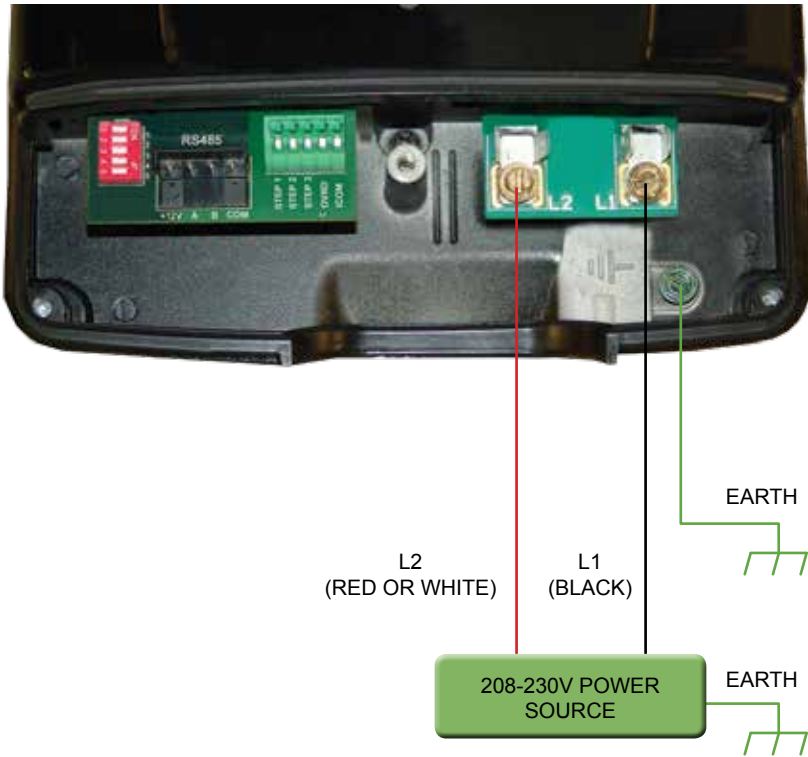

Figure 3: Mains Connection Diagram

VGreen 165 Controller

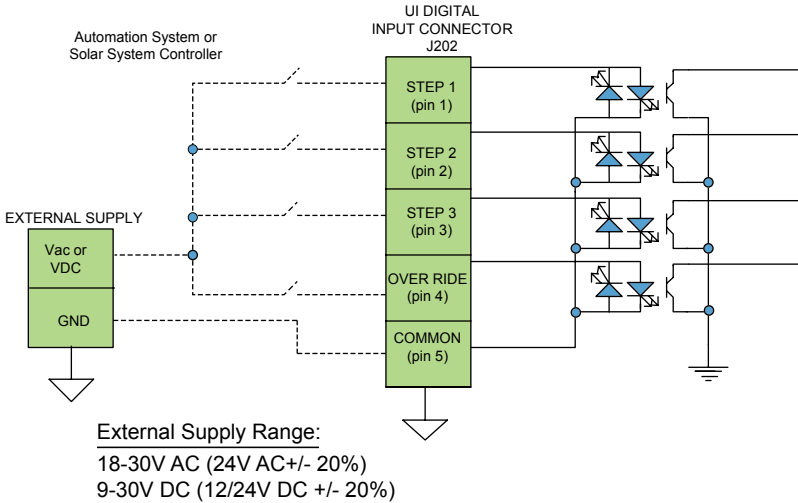

Figure 4: Wiring Diagram for Digital Inputs

⚠ WARNING

Access to these terminals is in close proximity to the mains connectors which carry line voltage capable of causing personal injury or damaging the equipment if contact is made.
Power should be turned off when accessing this area.



Figure 5: Digital Input connector

6 User Interface Operation

6.1 LED and Function Overview

Key for LEDs										
X	Solid ON Indication									
*	Blinking @ 1 sec									
**	Alternates between DURATION and SPEED									
#	Blink for three times @ 1 sec									

LED → Function ↓	Power	START	FAULT	STEP1	STEP2	STEP3	OVERRIDE	SPEED SETTING	DURATION SETTING	BARGRAPH
Power On	X									
Keypad Functions										
Step1	X	X		X				**	**	**
Step2	X	X			X			**	**	**
Step3	X	X				X		**	**	**
Override	X	X					X	**	**	**
Keypad lock	X			*	*	*				
Keypad Unlock	X			X	X	X				
Schedule Advance	X	*							X	X
Restore Default settings	X									# (All LED)
Motor pause	X	*					*	X		X
Temporary stop	X									* (0 RPM)
Digital Input Functions										
DI1 ON	X			*				X		X
DI2 ON	X				*			X		X
DI3 ON	X					*		X		X
DI4 ON	X						*	X		X
Serial Communication Functions										
Serial Communication	X							*		
Motor spinning	X							*		X
Freeze Protection										
Freeze Protection	X								*	X
Fault Handling										
UI fault	X		*							
Controller fault	X		X							

Figure 6: LED Functionality Table

6.2 User Interface Key Pad Overview

⚠ CAUTION

If power is connected to the VGreen 165 motor, pressing any of the following buttons referred to in this section 6.2 could result in the motor starting. Failure to recognize this could result in personal injury or damage to equipment.

1. **STEP 1 (Set Schedule)** → DURATION and SPEED
2. **STEP 2 (Set Schedule)** → DURATION and SPEED
3. **STEP 3 (Set Schedule)** → DURATION and SPEED
4. **OVERRIDE (Settings)** → DURATION and SPEED
5. **START**
6. **STOP**

6.3 Set the Schedule

⚠ CAUTION

If power is connected to the VGreen 165 motor, pressing any of the following buttons referred to in this section 6.3 could result in the motor starting. Failure to recognize this could result in personal injury or damage to equipment.

Set the DURATION and SPEED for the VGreen 165 using the keys on the User Interface. The schedule is based on a 24-hour schedule and will repeat each day of the week.

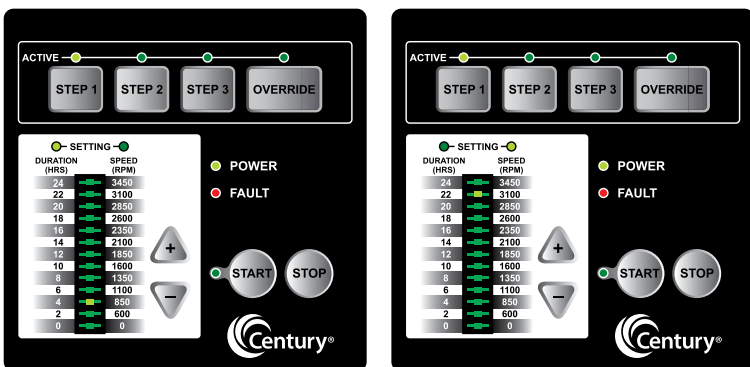

The highest speed rating for the VGreen 165 is 3450 RPM and the lowest is 600 RPM. Unless a new user-defined schedule is entered, the VGreen 165 will operate based on the following factory default schedule:

Button	Duration (In Hours)	Speed (In RPM)
STEP 1	4	3100
STEP 2	4	2600
STEP 3	8	1600
OVERRIDE	2	3450

Table 3: Factory default schedule

Schedule Tables

Use the tables below to record a personalized operating schedule. Recording the planned schedule in the table below will make the programming process easier and will help the user remember the custom settings in case of inadvertent loss of schedule. The user interface will not allow the user to program an overlap between different STEPs of the schedule. The STEP currently being set will always take priority over any previous settings. In the event a user attempts to program with a combined duration greater than 24 hours, the current STEP setting will be retained whereas the other two STEP settings will be cleared to zero hours requiring the user to reset them. Prior to beginning the actual programming process, it is advisable for the user to review the planned schedule as outlined in chart form to ensure the cumulative duration is not greater than 24 hours and no overlaps exist. It is always a good idea to double check your programmed settings for accuracy once you have completed the programming process.

Setup #1			
	Step 1	Step 2	Step 3
Duration			
Speed			

Setup #2			
	Step 1	Step 2	Step 3
Duration			
Speed			

Table 4: Custom Schedule

6.4 Running VGreen 165 from Keypad

⚠ CAUTION

If power is connected to the VGreen 165 motor, pressing any of the following buttons referred to in this section 6.4 could result in the motor starting. Failure to recognize this could result in personal injury or damage to equipment.

1. Press the START key and the VGreen 165 will run the programmed 24 hour duration schedule. The START event will be stored in the controller. Should a power outage occur, the VGreen 165 will automatically re-start at STEP 1 when power is restored.
2. The VGreen 165 will always run the PRIMING sequence when it starts from the OFF state, including when it automatically restarts following a power outage. The default Prime setting is defined in the “Priming” section of this document.
3. The VGreen 165 then starts running in STEP 1 at the programmed DURATION and SPEED. The “ACTIVE LED” for STEP 1 will turn ON. The DURATION and SPEED setting LEDs along with the respective bar graph LED will blink back and forth every three (3) seconds.

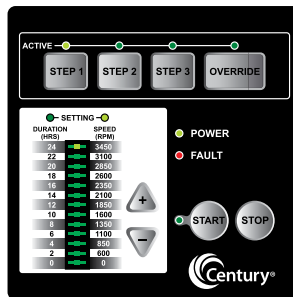
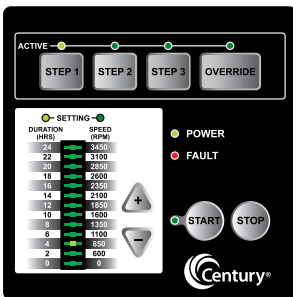

4. This sequence will then repeat for STEP 2 and then STEP 3 without the VGreen 165 stopping.
5. At the end of STEP 3, the VGreen 165 will wait if necessary for the completion of the 24-hour schedule. During this waiting period (if applicable), all of the “active step LEDs” will remain OFF. However, the START LED will still be illuminated. After completion of the 24 hour schedule, the system restarts at STEP 1 and this cycle will repeat indefinitely until the user presses the STOP key.

NOTE: Pressing a STEP key other than for the STEP currently running will cause an immediate transition to the newly selected STEP. The VGreen 165 will continue with the programmed schedule from that point forward.

NOTE: If STOP is pressed during normal schedule operation, the 24 hour schedule will stop. When START is pressed again, the 24 hour schedule will start from STEP 1.

NOTE: If power is lost while the VGreen 165 is running a 24 hour schedule, upon restoration of power the VGreen 165 will start the 24 hour schedule from STEP 1.

NOTE: If a digital input (provided from an external source) is detected, the VGreen 165 will start running on the STEP 1, STEP 2, STEP 3, or OVERRIDE speed corresponding to the digital input. Upon removing the digital input (provided from an external source), the VGreen 165 will stop and the user will need to press START to begin the 24 hour schedule operation. However, if START was already pressed prior to receiving a digital input, then the VGreen 165 will resume running the 24 hour schedule once the digital input is removed.

NOTE: Pressing STOP at any time turns the VGreen 165 OFF and clears the start time for the 24 hour schedule.

6.5 OVERRIDE

The VGreen 165 is equipped with an OVERRIDE feature, which can be engaged to temporarily run at higher or lower speeds ranging between 600 to 3450 RPM. Once the OVERRIDE duration has elapsed, the VGreen 165 will automatically return to the programmed schedule.

1. Pressing the OVERRIDE key while the VGreen 165 is running will cause the VGreen 165 to start running in the OVERRIDE mode at the programmed DURATION and SPEED. The “active LED” for OVERRIDE will illuminate. The DURATION and SPEED setting LEDs along with its respective bar graph LED will blink back and forth at three (3) second intervals.
2. The UP (+) / DOWN (-) arrows allow the user to configure OVERRIDE DURATION and SPEED. These settings can be changed while the VGreen 165 is running. These settings are stored each time the UP (+) / DOWN (-) arrows are pressed.

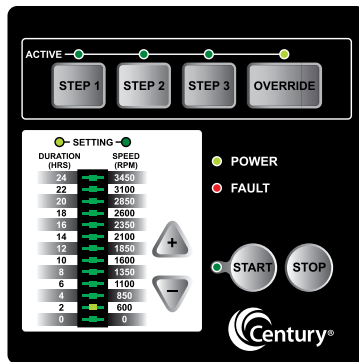

NOTE: When the OVERRIDE duration ends, the VGreen 165 resumes the 24 hour schedule at the point in the currently programmed 24 hour schedule where it normally would be running at that time. The OVERRIDE duration will not affect the start or stop times of the 24 hour schedule. For example, if OVERRIDE runs during a period overlapping with a later part of STEP 1 and an early part of STEP 2, the start time of STEP 3 is not affected.

NOTE: Pressing/Holding OVERRIDE key for more than three (3) seconds will cancel OVERRIDE mode.

NOTE: During the OVERRIDE mode, the VGreen 165 will not start with the priming sequence.

NOTE: It is recommended that you do not set the OVERRIDE duration to 0 HRS. Setting the OVERRIDE duration to 0 HRS will not allow you to change the duration setting while the motor is running. The motor will have to be stopped in order to change the OVERRIDE settings if the duration is set to 0 HRS.

6.6 Schedule Advance

⚠ DANGER

Do not perform any maintenance on the motor while the motor is in Schedule Advance Mode. The motor may start without warning. This event could cause death or serious personal injury.

The Schedule Advance mode allows the user to press the START button at one time of the day, with the 24-hour schedule starting at a different time of day. The VGreen 165 can run in the Schedule Advance mode (by using the OVERRIDE button) and upon completion will begin the programmed 24 hour schedule at STEP 1 DURATION and SPEED.

The following steps should be followed to set Schedule Advance mode:

1. With the VGreen 165 stopped, press and hold the START key for more than three (3) seconds. The START LED will blink at a rate of one second per pulse. The DURATION setting LED and respective bar graph LED will remain turned ON until the Schedule Advance mode is complete.

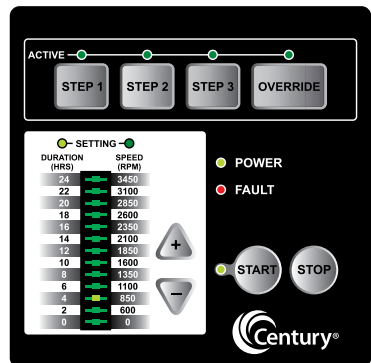

2. Press the UP (+) or DOWN (-) arrows to set the desired delay time after which the 24-hour schedule should start. The Schedule Advance mode will automatically start after the desired delay time is selected. The Schedule Advance mode can be canceled by pressing the STOP key.

NOTE: The OVERRIDE button will still function when the Schedule Advance mode is active. This will allow the user to run the VGreen 165 during the period of the Schedule Advance mode.

NOTE: While the VGreen 165 is in the Schedule Advance mode, if a user presses STEP 1, STEP 2, STEP 3 or the START key, the system will start the normal schedule and the Schedule Advance mode will be canceled.

NOTE: While the VGreen 165 is in the Schedule Advance mode, if a user presses the STOP key, then the Schedule Advance mode is canceled.

NOTE: If power is lost while the VGreen 165 is in the Schedule Advance mode, then the 24-hour schedule will automatically start when power is restored.

6.7 Key Lockout

⚠ CAUTION

Key lockout will not prevent the motor from being stopped by pressing the STOP button. If the motor is operating in “key lockout” mode, and being controlled through a digital or serial input, the motor will only temporarily stop (4 min.) it will then restart.

The VGreen 165 user interface has a “key lockout” feature to prevent unwanted changes to the settings.

To lock the keys, hold down the “STEP 1, STEP 2, and STEP 3” buttons all at the same time for at least three seconds. The “active LEDs” for STEP 1, STEP 2, and STEP 3 will blink for 30 seconds indicating that the keypad is locked.

The user can unlock the keys by holding down the same three STEP buttons for at least three seconds. The “active LEDs” for STEP 1, STEP 2, and STEP 3 will illuminate temporarily indicating the keypad is unlocked.

NOTE: While operating in “key lockout” mode the motor can still be stopped by pressing the stop key. If no digital or serial input is present the motor will remain stopped. If the motor is being controlled by a digital or serial input the motor will only temporarily stop for 4 minutes. See section 6.9 for more information on temporary stop.

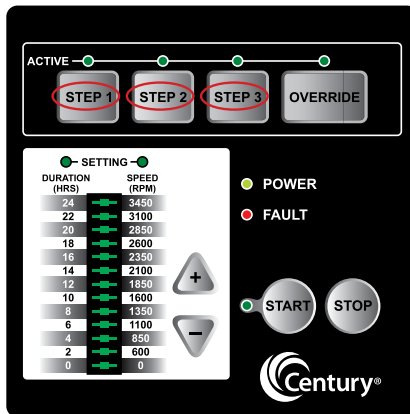

6.8 Motor Pause

The VGreen 165 user interface has a “motor pause” feature that will allow the user to temporarily stop the VGreen 165 for maintenance work without disrupting the 24 hour schedule (i.e., for backwashing the filter). If the VGreen 165 is currently running, the user can press and hold the START button for more than three (3) seconds and the VGreen 165 will stop and remain off until the user presses and holds the START button again for more than three (3) seconds. The START and OVERRIDE buttons will blink once every second indicating that the “motor pause” feature is enabled. These LEDs will stop blinking once this feature is canceled.

6.9 Temporary Stop with Digital / Serial Input

 CAUTION

Temporary stop functionality only works while the VGreen 165 is being controlled by a digital or serial input. If the motor is being controlled by the integrated key pad and STOP is pressed, the motor will stop and remain stopped.

The VGreen 165 has a “temporary stop” feature that will immediately stop the VGreen 165 when being controlled by a serial or digital input. The user can press the STOP button while the VGreen 165 is running and the VGreen 165 will stop and stay off for four (4) minutes. Once this time has elapsed, the VGreen 165 will return to normal operation and accept an input from digital or serial input source. Refer to section 9 for additional details on digital inputs.

NOTE: If the VGreen 165 is operating from serial or digital input, the ‘0 RPM’ LED of the bar graph will blink once every second indicating the “temporary stop” feature has been activated. After the specified time period, the VGreen 165 will return to normal operation and accept an input from any digital or serial input source. Refer to section 9 for additional details on digital inputs.

6.10 Reset Factory Defaults

The VGreen 165 user interface has a “Reset to Factory Defaults” feature to restore the schedule settings back to the original values programmed at the factory. The user must press and hold the STOP and OVERRIDE buttons for three (3) seconds to reset the settings back to factory defaults. All of the UI bar graph LED’s will flash three (3) times to confirm the settings were restored to factory defaults.

7 Priming

The VGreen 165 will always run the PRIMING sequence when starting from the OFF state, except when starting in OVERRIDE. The factory Prime settings are 2600 RPM for three (3) minutes.

8 Freeze Protection

NOTICE

The freeze protection function will NOT operate if the START button is not pressed. This can be confirmed by verifying that the START LED is illuminated.

In the event that the outside air temperature drops below a set threshold, the VGreen 165 will automatically turn on (assuming the START button has been pressed) and circulate the pool water. The Freeze Protection will run according to the following conditions (utilizing the factory default settings):

Freeze Protection turn ON temperature = 39°F

Freeze Protection Duration = 8 Hours

By utilizing the VGreen 270 user interface (accessory sold separately) these factory default settings can be changed.

Once this eight (8) hour period has elapsed, the VGreen 165 will check the ambient temperature again. If the temperature is still below the set threshold, the VGreen 165 will run for an additional 8 hours. If the temperature is above the threshold, the VGreen 165 will automatically return to the 24-hour based schedule.

9 Control with Digital Inputs

The user can run the VGreen 165 at the programmed STEP 1, STEP 2, STEP 3, or OVERRIDE speeds by utilizing the four digital inputs. STEP 1, STEP 2, STEP 3, or OVERRIDE are equivalent to Digital Input 1, 2, 3 or 4 respectively.

NOTE: The controller is rated to accept digital inputs of 18V-30V AC (24V AC +/- 20%) and 9-30V DC (12/24V DC +/- 20%).

NOTE: The VGreen 165 will detect either a 50/60Hz for AC input or an active low signal for DC digital inputs.

The items below describe the functionality of the digital inputs:

1. If the user provides any one of the 4 digital inputs, then the corresponding ACTIVE STEP LED will blink every one (1) second. The SPEED LED and corresponding bar graph LED will be illuminated to indicate the Digital Input is functioning properly.
2. The START LED will be OFF when a digital input is present.

 **WARNING**

Access to these terminals is in close proximity to the mains connectors which carry line voltage capable of causing personal injury or damaging the equipment if contact is made. Power should be turned off when accessing this area.

NOTE: A generic wiring diagram is provided in figure 7 for connecting the VGreen 165 to a “System Level Controller”. This concept can be applied to a solar system or any other type of control system.

NOTE: There is no schedule for digital inputs. The timing for each speed is controlled directly by the digital inputs.

NOTE: The digital inputs have the highest priority amongst all the inputs (i.e., keypad, serial, or digital). Therefore the serial commands as well as the User Interface inputs will be ignored when a digital input is present.

NOTE: If more than one digital input (switch) is present, then the VGreen 165 will give priority to the highest number digital input. Therefore OVERRIDE has highest priority followed by STEP 3, then STEP 2, then STEP 1.

NOTE: If no digital input is detected, the VGreen 165 will automatically start the 24 hour schedule if the START key was pressed prior to the application of a digital input.

⚠ WARNING

Access to these terminals is in close proximity to the mains connectors which carry line voltage capable of causing personal injury or damaging the equipment if contact is made. Power should be turned off when accessing this area.

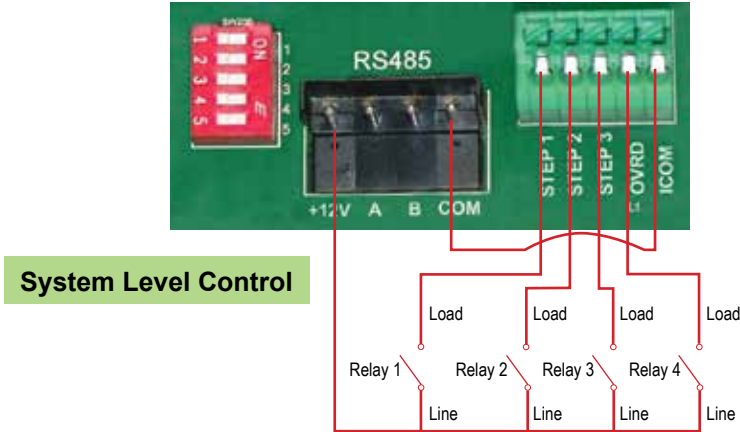

Figure 7: System Level Control Wiring Diagram

10 DIP Switches

⚠ WARNING

Access to these terminals is in close proximity to the mains connectors which carry line voltage capable of causing personal injury or damaging the equipment if contact is made. Power should be turned off when accessing this area.

The DIP switches can be used to configure different settings for the VGreen 165. Each DIP switch and their corresponding function is defined in Table 5.

Switch #	Function
1	Power output on/off
2	Not Used
3	Not Used
4	Not Used
5	Not Used

Table 5: DIP Switch Functions



Figure 8: DIP Switches

11 Care and Maintenance

The VGreen 165 is both reliable and robust in harsh environments. However, this product does contain electronics that are cooled by a fan mounted to the VGreen 165. In order to ensure optimum reliability of this product, it is recommended to clean the fan inlet on the back of the VGreen 165 once a month. It is also important to keep this area free of large debris such as leaves, branches, mulch, plastic bags, etc.

12 FAULT Status

WARNING

While the FAULT LED is illuminated the motor will not run, upon clearing the fault, the motor may automatically resume running depending on where in the schedule the FAULT occurred. This may cause personal injury or damage to the equipment.

The paragraphs below illustrate the possible faults that can occur with the VGreen 165. If the VGreen 165 does not restart automatically following the FAULT, cycle ac power to the VGreen 165 and wait five (5) minutes. If this does not correct the situation, please contact Customer Service at 1-800-262-6484.

The VGreen 165 reads the FAULT status and provides feedback to the user via the FAULT LED. The VGreen 165 will illuminate the FAULT LED when a FAULT is present. The VGreen 165 will stop and remain OFF when the FAULT is present. Once the FAULT is cleared, if the VGreen 165 was previously running, it will automatically resume running the normal schedule.

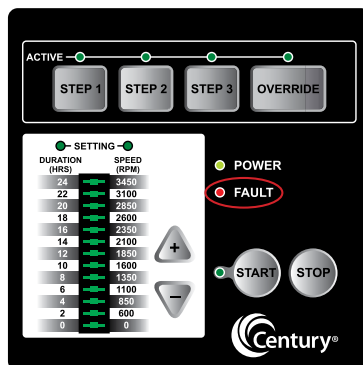

Below is the behavior of the FAULT LED when a FAULT is detected:

1. When a FAULT is present, and the motor is **not** running, only the FAULT LED and power LED will illuminate.
2. When a FAULT is present, and the motor is running, then the FAULT LED will illuminate. During the FAULT condition, the bar graph LEDs on the interface will turn OFF. However, the power LED, start LED & active STEP LED will remain illuminated.
3. When a FAULT is present and the FAULT LED is illuminated, only the STOP key will function. The remaining buttons become disabled.
4. When the FAULT LED is continuously ON (i.e. not blinking), a FAULT is present in the controller. When the FAULT LED is blinking every one (1) second, a FAULT is present in the user interface.
5. When the FAULT has cleared, the FAULT LED will turn OFF.
6. Once the FAULT is cleared, if the VGreen 165 was previously running, it will **automatically** resume running the normal schedule.

Please see Section 14 for troubleshooting issues and their resolutions.

13 Specifications

Overall Ratings

Input Voltage	208 - 230 Vrms nominal	
Input Current	10.5 - 10.0 Arms	
Input Frequency	Single phase, 60 Hz	
Control Terminals	18-30V AC (24V AC +/- 20%) or 9-30V DC (12/24V DC +/- 20%)	
Auxiliary Load Terminals	N/A	
Maximum Continuous Load	1.65 THP (Total Horse Power)	
Speed Range	600 - 3450 RPM	
Environmental Rating	NEMA Type 3R	
Agency Approval	R/C XDNW2.E302804 R/C XDNW8.E302804	
Ambient Conditions		
	Storage	-40°C to +85°C (-40°F to +185°)
	Operating	0°C to +50°C (+32°F to +122°F)
	Humidity	Relative 0 to 95 % non-condensing



14 Troubleshooting Guide

⚠ WARNING

Diagnosing certain symptoms may require close interaction with, or in close proximity to, components that are energized with electricity. Contact with electricity can cause death, personal injury, or property damage. When trouble shooting the VGreen 165, diagnostics involving electricity should be cared for by a licensed professional.

Symptom	Possible Causes	Potential Solutions
VGreen 165 FAILS TO START	Controller DIP switches not configured properly	Verify that the DIP switches of SW100 under the controller terminal box cover are in the correct position. Refer to section 10.
	Mains Voltage is not present	Replace fuse, reset breaker/GFI.
		Tighten mains wire connections.
	User Interface is not connected	Check connections at J201 connector.
	VGreen 165 shaft is locked	Check if the VGreen 165 can be rotated by hand and remove any blockage.
VGreen 165 shaft is damaged	Replace VGreen 165.	
VGreen 165 RUNS THEN STOPS	Over temperature FAULT	Check that back of VGreen 165 is free from dirt and debris. Use compressed air to clean.
	Over current FAULT	VGreen 165 will automatically restart after one (1) minute.
VGreen 165 IS NOISY	Debris in contact with fan	Check that back of VGreen 165 is free from dirt and debris. Use compressed air to clean.
	Debris in strainer basket	Clean strainer basket.
	Loose mounting	Check that mounting bolts of VGreen 165 and pump are tight.
VGreen 165 RUNS, BUT NO FLOW	Impeller is loose	Check that VGreen 165 is spinning by looking at fan on back of VGreen165. If so, check that pump impeller is correctly installed.
	Air leak	Check plumbing connections and verify they are tight.
	Clogged or restricted plumbing	Check for blockage in strainer or suction side piping.
Checked for blockage in discharge piping including partially closed valve or dirty pool filter.		

Disclaimer

The information in this document incorporates proprietary rights and is not to be duplicated wholly or in part without the express written permission of Regal Beloit America, Inc. © Copyright 2016.

The text and images in this document are not to be modified without express written permission of Regal Beloit Corporation and / or Regal Beloit America, Inc.

Regal Beloit America, Inc.
531 North Fourth Street
Tipp City, OH 45371
Fax: (937) 667-5030

www.centuryelectricmotor.com
Customer Service 1-800-262-6484

Please refer to our website
www.pool-motors.com
for updates to this printed manual.



Distribution Marketing
1325 Heil Quaker Blvd.
LaVergne, TN 37086
Phone: (866) 887-5216
Fax: (800) 468-2062
www.pool-motors.com

A Regal Brand



www.regalbeloit.com