

Installation Manual

Read the complete installation manual and Owners Manual before beginning the installation.

- Sizing the System** Size the system using the “Simplified Sizing Guide For Solar Pool Heaters.” From this form you will determine the System Size in Square Footage. Based on this area, choose a panel size. Panels are available in 4’x8’, 4’x10’, and 4’x12’. Divide by 32, 40 or 48, respectively, to determine the number of panels. Using larger panels, where possible, results in a lower cost per square foot.
- Where to Install** Determine the roof(s) where the panels will be installed. In the northern hemisphere, the panels may be faced (in the order of efficiency) south, flat, west or east. Panels may never face north. Panels must be mounted at a minimum of 15° for proper drainage. In tropic and sub-tropic climates, the panels may be installed on flat roofs (in the event of freezing conditions, the water from the pump must be circulated through the system to prevent panel damage.) Most roof surfaces are acceptable for installation; including shingle, barrel tile, flat tile, metal, cedar shake, built-up gravel and modified roof systems. The system can also be installed on a aluminum or wood ground mounted rack system. For more information on rack or flat roof installations, consult our technical support team.
- Verify Space Requirements** Determine the available area on the roof(s) for the installation. Panels are 48” wide with a 3” gap between absorbers for mounting, totaling 51”. Panels are placed next to each other in a row; each panel requires 51” horizontally (i.e. 7 - 4’x10’ panels would be 357” horizontal by 120” vertical.) Panel Rows may be *split* to circumvent large obstacles, to install one row above another row, or to install on separate roofs. Each split requires a “Split Kit.” Panels may be spaced around small vents up to 5” without a “Split Kit” provided they fall between panels by using a 6” rubber connector. Each Row requires a minimum of 3” on all sides to allow for feed and return plumbing. See the chart below for typical system space requirements (the Overall Length includes the 3” on each side.) Different size panels may be combined; however, we suggest you call for technical assistance on these types of installations.

# panels	Overall Length	# panels	Overall Length
3	13’3”	8	34’6”
4	17’6”	9	38’9”
5	21’9”	10	43’0”
6	26’0”	11	47’3”
7	30’3”	12	51’6”

- Typical Panel & Plumbing Layouts** See typical layouts below. Do not use more than 12 panels in any row. For larger systems, split the panels into several rows. Feed the water into the bottom corner and return from the opposite top corner. Never use “Bottom End Feed Same Top End Return” because of reduced efficiency at the

opposite end panels. All bottom headers and feed plumbing should allow for gravity drain. In tropic or sub-tropic climates, the panels and plumbing may be level; in northern climates, they must be installed with a 1/4” per foot slope towards the feed. Refer to the owner’s manual for draining requirements. All return lines from separate panel rows must meet at the highest point of the system.

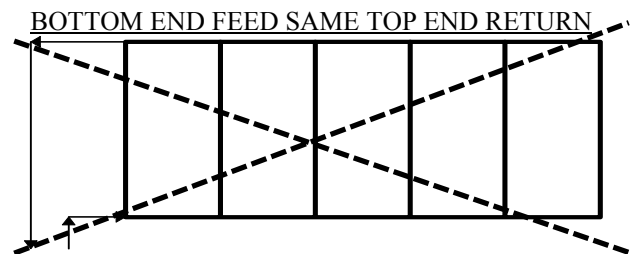
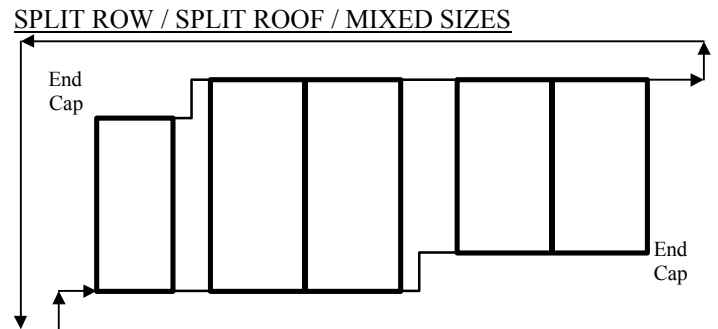
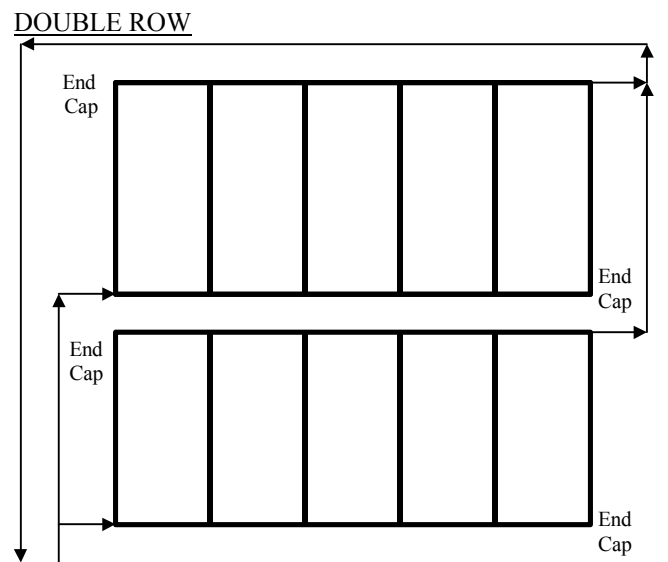
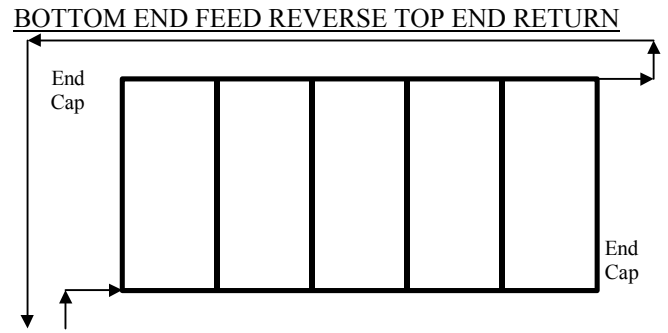

5. **Installation Materials** Below is a standard list of materials required for a typical installation.

PANEL KIT (1 per Panel)

K15PAN-SD

<u>Kit includes</u>	<u>Qty</u>
3" Rubber Hose Connector	2
Stainless Hose Clamp	5
Stainless #14x2" 3/8 Hex Screw	4
Stainless Header/Strap Clip	4

SYSTEM KIT (1 per System)

K15SYS-SD

<u>Kit includes</u>	<u>Qty</u>
Panel Kit Content +	
Pipe to Panel Adapter	4
Note: 2" Split Plumbing Standard; 1 1/2" Kits by request	

SPLIT KIT (1 per Split)

K15SPL-SD

<u>Kit includes</u>	<u>Qty</u>
Panel Kit Content +	
Pipe to Panel Adapter	4
Note: 2" Split Plumbing Standard; 1 1/2" Kits by request	

HOLD DOWN STRAP

<u>Size</u>	<u>Straps</u>	<u>Ft</u>
4'x8'	2	9
4'x10'	3	13.5
4'x12'	3	13.5

PVC PIPE per Ft

(Standard amount shown below)

<u># of Panels</u>	<u>Ft</u>	<u># of Panels</u>	<u>Ft</u>
4	100	5 - 7	120
8 - 12	140	13 - 18	160

Note: For Tile Roof Installations, request Tapcon screws

Allow a minimum of 3" on all sides of the panel row for piping. Inspect the roof for any sharp projections that may damage the panels. If there are any vents, chimneys or other obstructions, layout the system before attaching the panels.

Begin installing the panels from left to right (or right to left) working towards the opposite end. Vortex Panels use a header design where the board attaches to the middle of the bottom and top header. This design reduces the buildup of snow, leaves and debris on the absorber surface near the header. The panel can be installed either side up, and can be reversed after five or more years to lengthen its life.

- Step 7.1: Lay the top header approximately 1 1/4" below the horizontal chalk line. Using the parts from the Panel Kit, install a 3" Rubber Coupling on the right end top & bottom header outlet. Notice that the header outlet has a groove near the end. Install a Stainless Hose Clamp over each Rubber Hose Connector and position it over the groove; position the head of each clamp facing out and up for easy access, then tighten until snug.

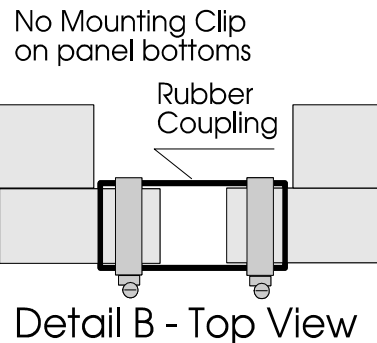

6. **General Tools Required**

1/4" Variable speed drill
 5/16" & 3/8" Nut driver
 Caulking gun
 Chalk line
 Tape measure
 Level
 Hacksaw or pipe cutter
 PVC glue & cleaner

7. **Panel Installation** The following procedure assumes a shingle roof; for other roof types including flat roofs, see the section on Special Roof Requirements. Establish a horizontal chalk line across the roof for the location of the top of the system. This line must have 3/4" clearance above and below it for mounting the Header Clip on a flat surface. For tile roofs, the line should be approximately 2" above the bottom of the tile. (For northern climates, this line must have a 1/4" per foot slope towards the feed end to allow for drainage.)

Then drop a vertical line (90° to the horizontal line) at the left or right end of the installation to locate the first panel.

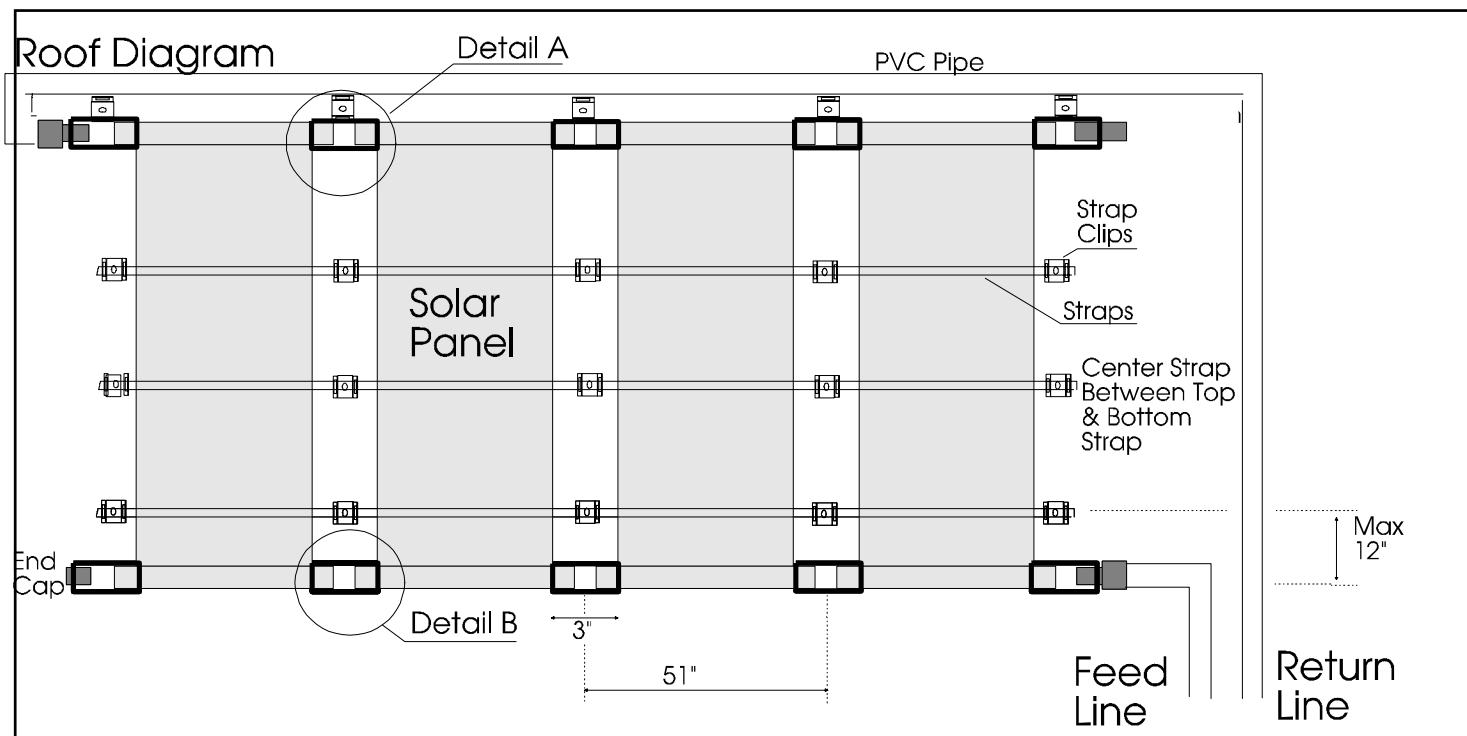

Step 7.2: Slip a Hose Clamp over the bottom and top Rubber Hose Connector. Position the next panel to the right of the first panel, and insert the header outlet into the top and bottom Rubber Hose Connector of the first panel. Position each Hose Clamp over the groove of the second panel; facing out and up for easy access, then tighten until snug. The top and bottom should look like the diagram labeled Detail B when finished. If the roof is not too steep for the panels to slide, you may continue connecting panels following Step 7.1 then Step 7.2; otherwise move to Step 7.3.

Step 7.3: Verify that the panels are in position (the top edge of the header should be parallel to the horizontal line; the left edge of the very first panel should be on the vertical line.) Then mark the horizontal line directly above the center of the top Rubber Hose Connector. Apply a generous amount of sealant to the bottom of the Stainless Header Clip, and position it on this mark with

to strip the screw in the wood. Also be sure the lip on the Clip is square against the Rubber Coupling. Apply a small amount of sealant over the head of the screw. When complete, it should look like the diagram to the left.

Step 7.4: Open the last Hose Clamp and slip the end down through the Stainless Header Clip (slotted end with a lip) and around the under side of the Rubber Hose Connector. Close the Hose Clamp and tighten snugly around the Rubber Hose Connector so that it is firmly

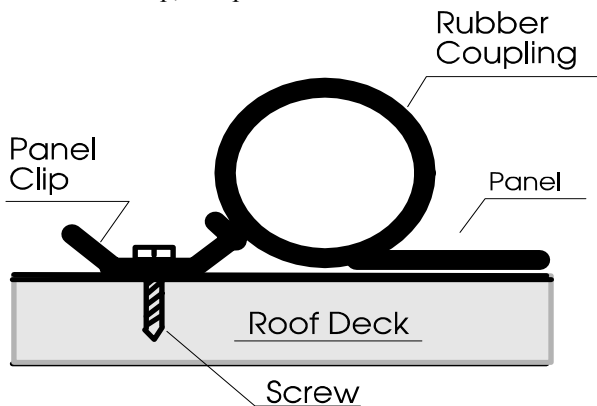

the lip end facing the panel. Using the drill and the 3/8" nut driver, install a Stainless #14x1 1/2" 3/8 Hex Screw through the hole in the middle of the Header Clip into the roof until tight. The Clip should be tight, but be sure not

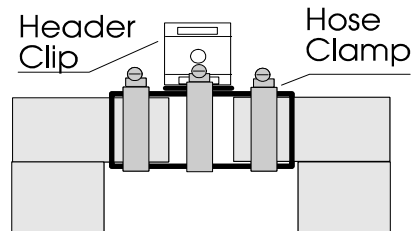

Detail A - Top View

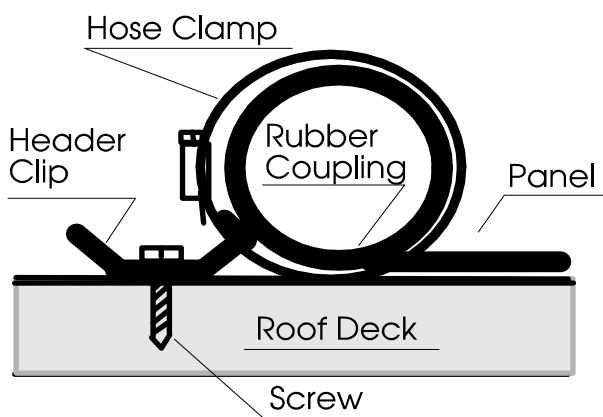

Detail A - Side View

seated against the lip of the Header Clip as shown in Detail A. Continue with Step 7.1 through Step 7.4 until all panels in the row are installed. Note that the bottom headers are not secured with a Header Clip to allow for expansion.

Step 7.5: The completed row should look like the Roof Diagram on the previous page. It may vary based on the actual layout. To finish the row, use the parts from the System Kit. Install a Rubber Hose Connector on the four outside panel corners using the Hose Clamps. On the feed and return corners, insert the Pipe to Panel Adapters into the Rubber Hose Connector using the end that resembles a header outlet; secure with a Hose Clamp. On the remaining two corners, insert an End Plug. Be sure that the End Plug is inserted with the lip facing in towards the panel so that lip is in between the Hose Clamp and the panel. Secure the two top end Rubber Hose Connectors to the roof with Header Clips just as you did for each panel.

Step 7.6: The Hold down Straps may now be installed (especially in windy conditions); however, it is common to save this step for last. Using the guide in the Installation Materials Section 5, determine how many Straps will be needed. The bottom Strap is always located 12" above the bottom header. The remaining Strap(s) are equally spaced between the bottom Strap and the top header. You may want to use a chalk line to mark this spacing before you install the panels by measuring down from the top horizontal line; or use the shingle lines as a guide. Leave clearance on each side of each line for the Panel Clip to be mounted on a flat surface. Each Strap Clip is installed like the Header Clips, except that the slots face left to right (with no regard to which side the lip faces.) Space them equally between each panel absorber and install with sealant and a Stainless #14x1/2" 3/8 Hex Screw. The Strap is then threaded through each side of each Strap Clip from left to right.

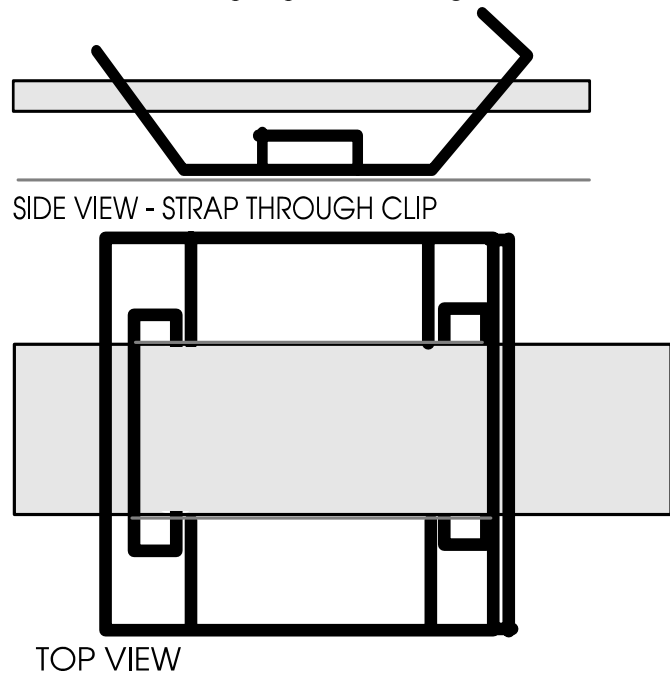

On each row end, the Strap is threaded back through the inside slot of the Clip as shown below. Before doing this on the opposite end of the Strap, pull the Strap to apply tension (approximately 2" to 6" elongation.) After the

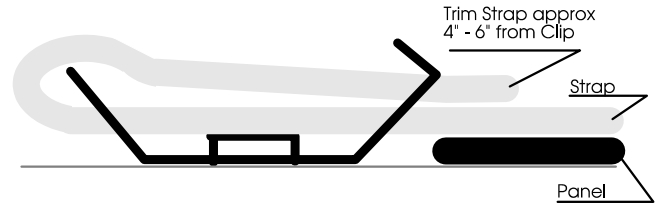

SIDE VIEW - END CLIP W/STRAP LOOPED BACK THROUGH CLIP system is installed for several weeks or even months the Strap may need to be retensioned; this is due to expansion of the strap in warmer weather.

In high wind areas order "Strap Clamps" for securing the ends of the strap. Additional straps may also be used.

8. Bottom End Plumbing A typical plumbing layout is shown below. The tie-in for the solar plumbing is always down stream of the filter. Note that the check valves and 3-way valve accept 1/2" pvc pipe inside or 2" fittings outside. You may use 1/2" pvc pipe for the bottom end plumbing; however, you should use 2" pvc pipe where possible. 2" pvc pipe is recommended above the 3-way and tee. Always use pvc cleaner on all pipe ends and fitting sockets. Use a generous amount of pvc glue on pipe ends and fitting sockets, immediately inserting with a twisting motion. Hold together for at least 30 seconds. Follow the instructions on the cleaner and glue can for proper use.

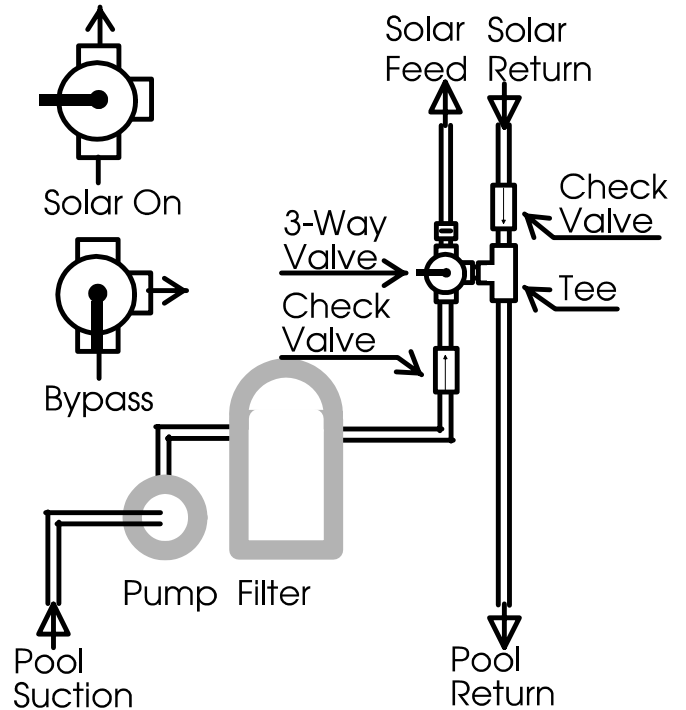

Bottom End Plumbing (Right Side Return)

Determine the layout of all the valves and fittings before proceeding. Cut the line after the filter in an area with enough clearance for the new fittings. Install a check valve between the filter and the 3-way valve, with the flow pointing away from the filter (the cone inside the check valve will be facing towards the filter.) Be certain not to allow glue to seal the cone inside the check valve. Typically the 3-way is mounted against the wall of the building approximately 3' to 4' off the ground with the side outlet facing right and the inlet facing down. Use a 2½" galvanized pipe clamp over the bottom inlet of the valve to secure it to the wall with screws. Plumb into the "inlet" of the 3-way valve from the check valve. The plumbing then continues up the wall, around the eave and onto the roof feeding the solar panels. The side outlet of the 3-way valve connects to the side outlet of the 2" tee. The return from the solar connects to the top of the tee. The bottom of the tee returns to the line going to the pool jets. Install a check valve on the solar return line above the tee, with the direction of flow going into the tee. Most accessories including auxiliary heaters, chlorine feeders, Pool cleaner pumps should be on the return line after the tee. Automatic pool cleaner pumps must be run at night when the solar is off or during the day only after the solar is already running. Failure to do so may result in a burnt-out cleaner pump.

For installations requiring the return solar line on the left, proceed as follows: Install the 3-way valve with the side outlet facing **left** into the tee. Remove the face plate of the 3-way valve and rotate the face plate 90° clock-wise so that the "inlet" stamp is facing the side of the valve with no outlet; reassemble.

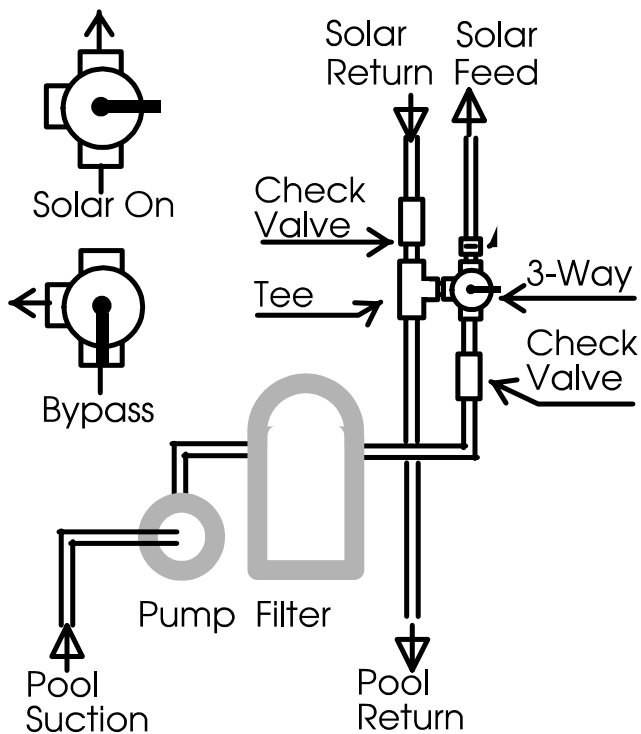

**Bottom End Plumbing
(Left Side Return)**

9. **Pipe Layout** Use 2" Schedule 40 PVC plastic piping between the bottom end plumbing and the panels. White pipe is recommended because of its excellent outdoor life. The pipe may be painted with a good outdoor paint to match the structure or roof. 1½" pipe may be used on splits between panel rows. All plumbing should allow for gravity drain. In tropic or sub-tropic climates, the panels and plumbing may be level; in northern climates, they must be installed with a ¼" per foot slope towards the pool equipment. The panels should gravity drain back to the pool. Refer to the Owner's Manual for draining requirements. If it is not possible to route plumbing to allow for panel drainage, a manual drain valve or line should be installed, or the end plugs may be removed to drain panels. Support all pipes every 4' using 2½" Galvanized Pipe Clamps.

10. **Flow Rate** The sizing calculations made to determine the number of panels to install must be matched to the flow rate from the pool pump, to operate at maximum efficiency. The ideal flow of water per panel is 3 to 5 gallons per minute. The acceptable range is from 3 to 8 gpm per panel. The total gpm flow rate supplied by the pool pump is divided by the number of panels installed to determine this figure. The gpm rating of a pool pump (as indicated on the pump or in the operating manual) will not be its actual output because of the pressure drop due to piping, filter, fittings, and the panels (only when panels are on.) The actual output must be measured by an in-line flow meter or calculated from the pump's efficiency curve. (As the pressure drop increases gpm decreases.) The gpm rate can also be estimated using the pump rating or by consulting the manufacturer. If there is inadequate flow, reducing the number of elbows or using 2 - 45° elbows instead of 90° elbows will reduce friction loss and increase flow. A larger pump (or upgrading the pump motor and impeller) may be required if the flow is below 3 gpm per panel. A simple test to insure that the panels have enough flow is to feel the surface of the panels on a sunny day; it should feel cool to the touch (the heat is being absorbed into the water). If there is too much flow, throttle the 3-way valve towards the bypass to divert additional flow; or install a bypass line across the feed and return lines with a ball valve for adjusting and bypassing flow.

A properly sized pool pump and filtration system will circulate the entire volume of pool water once each day; typically in a 8 to 10 hour cycle. Panel sizing is based on circulating the entire volume of pool water through the panels once each "solar" day. If the filtration system is under sized or can not be extended to run 8 hours per day, a booster pump will be required.

11. **Startup & Testing** Consult the owner's manual for complete startup procedure. After system is filled with water, check all fittings, hose couplings and panels for leaks. Set the time clock to operate during the solar day, typically 9am to 5pm. Feel the surface of each panel to ensure proper flow; as the pool water flows through it on

startup it will cool to the temperature of the pool water. Check for air bubbles from the pool jets.

12. **Correcting Problems:** Problem: Air bubbles coming out of the pool jets. This condition results in poor heat transfer, and should be corrected. Solution: First, check the pool pump basket for air bubbles. If the basket is not completely clear of bubbles, there is a good chance that there is a suction leak between the pump and the pool. Check the skimmer to insure the water is at the proper level. Lubricate the basket lid o-ring (consult the pump instructions.) There may be a suction leak between the pump and the pool, or in the pump internal gaskets. This may require a professional to service. Tighten the stainless hose clamps on each rubber coupling. Next try reversing the location of the vacuum breaker valve and end plug on the solar panels. On some systems, the water flows down from the panels faster than the pump will supply it. This allows air to draw in at the rubber connectors. First try tightening the hose clamps; next install a ball valve in the return line from the solar above the tee. Adjust the valve closed slowly over a five minute period until the bubbles have stopped. If this valve is closed 50% or more, there may be other problems; consult the technical support line or a professional. The pool pump may be under sized, not supplying adequate lift and flow to fill the panels.

Problem: Inadequate heating. Solution: Inadequate flow; see section on flow rate. Improper time clock setting; systems with a southern exposure should run from 9 AM until 5 PM. Heat loss at night; use a solar pool cover to insulate the pool surface against heat loss when night time temperatures are below 60°F. Shade on the panels; remove obstruction or set time clock to run only when panels have sunlight on them. Under sized system; increase the number of panels.

12. **Special Roof Requirements:** Variations in the installation procedures are outlined below. Consult the technical support for other types of roof installations.

Flat Tile or Barrel Tile Roofs: The mounting hardware is attached to the tile using Tapcon Screws supplied with the kit (you must specify tile roof when ordering). This requires drilling a pilot hole in the tile before inserting the screw. Use a 3/16" masonry drill bit. DO NOT drill into the substrate below the tile; doing so will cause a roof leak. The mounting screws should be positioned 1" to 2" above the bottom edge of the tile. This will allow a space between the tile and the substrate due to the overlap in the tiles. On barrel tile roofs, try to lay out the panels so that the mounting holes fall on the tops of the barrel tile. This can be accomplished by using 6" rubber couplings where additional spacing is required; cut the coupling to the correct length.

Cedar Shake Roofs: If the cedar shakes are installed on top of a plywood surface, use a galvanized metal flashing (approximately 4"x4") under each shake where the mounting screw will penetrate. Center the flashing under

the penetration location before installing the screw. Drill a pilot hole and apply a generous amount of sealant into the hole. If the cedar shakes are installed on fir strips, call for alternate installation method.

Flat Built-up Gravel Roofs: Use caution when installing on this type of roof. The roof must be in good condition and be completely dry. If you are uncertain of the condition of the roof, consult a professional. At each mounting location remove the loose gravel in an area approximately 6"x6". At the exact location of the penetration, remove the gravel which is embedded into the tar surface of the roof using a chisel or the back of a claw hammer. Scrap back the gravel until you have a smooth tar surface approximately 2"x2". Apply a generous amount of sealant under the mounting hardware and over the head of the screw once installed. Using a 2" to 2½" fender washer under the mounting hardware will provide additional mounting surface. The screw must be tightened to hold the hardware securely to roof surface; however, use extreme caution not to over tighten and strip the screw in the plywood. An alternate method is to have a roofing contractor install "roof curbs" where the mounting hardware will be installed.

Open Beam Roofs: Any ceiling with exposed beams must be checked to avoid the screw ends from penetrating into the interior space. Call for alternate installation method.

Metal Roofs: If the metal roof is installed on a plywood surface, you may proceed using the normal installation method. If the metal roof is installed on fir strips, the mounting hardware must penetrate into the fir strip to insure a good seal and to avoid bending the metal surface.

Rubber or Asphalt Modified: This type of roof is typically installed flat. Using a 2" to 2½" fender washer under the mounting hardware will provide additional mounting surface. Be sure to use a generous amount of sealant under the washer, between the washer and the mounting hardware, and on top of the mounting screw.

Roof or Ground Mounted Rack Systems: Rack systems can be made from pressure treated wood or aluminum. For roof mounted racks aluminum is preferred for its additional strength and longevity. Aluminum racks are available in a kit form. To order a kit, or to request a wood rack design specification sheet, call the technical support line.